

# RTX600-RTN600 Series

Controllers for freezer cabinet and cold rooms.



ENVIRONMENTALLY  
OPTIMISED



Controllers for freezer cabinet and cold rooms  
with built-in compressor.

USER  
GUIDE

# CONTENTS



<b>1 - INTRODUCTION</b> .....	<b>6</b>
1.1 - MAIN FEATURES .....	6
1.2 - DESCRIPTION.....	6
<b>2 - SPECIFICATIONS</b> .....	<b>7</b>
2.1 - TECHNICAL SPECIFICATIONS (EN 60730-2-9) .....	7
2.2 - FURTHER INFORMATION .....	7
2.2.1 - INPUT CHARACTERISTICS.....	7
2.2.2 - OUTPUT CHARACTERISTICS .....	7
2.2.3 - MECHANICAL CHARACTERISTICS.....	7
2.2.4 - REGULATIONS .....	7
2.3 - CONNECTIONS .....	8
2.3.1 - RTX600 TERMINALS .....	8
2.3.2 - RTN600 TERMINALS.....	9
2.3.3 - CONNECTING A D.I. TO PB1...PB7 INPUTS.....	10
<b>3 - APPLICATIONS</b> .....	<b>12</b>
3.1 - SUMMARY .....	12
3.2 - APPLICATION 1 .....	14
3.3 - APPLICATION 2.....	15
3.4 - APPLICATION 3.....	16
3.5 - APPLICATION 4.....	17
3.6 - APPLICATION 5.....	18
3.7 - APPLICATION 6.....	19
3.8 - APPLICATION 7.....	20
3.9 - APPLICATION 8.....	21
<b>4 - KEYBOARD USER INTERFACE AND START-UP</b> .....	<b>22</b>
4.1 - LED.....	22
4.2 - KDEPLUS .....	23
4.3 - KDWPLUS.....	24
4.4 - CONNECTIONS WITH REMOTE TERMINAL AND REMOTE DISPLAY.....	25
4.5 - PRELIMINARY SETTINGS .....	26
4.5.1 - SELECTING APPLICATIONS .....	26
4.5.2 - RESET PROCEDURE.....	26
4.5.3 - PASSWORDS .....	26
4.5.4 - SETPOINT: SETTING AND EDIT LOCK.....	27
4.5.5 - DISPLAY PROBES VALUE .....	27
4.5.6 - KEY-ACTIVATED FUNCTIONS.....	27
4.5.7 - "MACHINE STATUS" MENU .....	28
4.5.8 - PROGRAMMING MENU .....	29
<b>5 - FUNCTIONS AND REGULATORS</b> .....	<b>30</b>
5.1 - SETTINGS .....	30
5.1.1 - PROBE SETTING AND CALIBRATION.....	30
5.1.2 - DISPLAY SETTINGS .....	30



<b>5.2 - FUNCTIONS.....</b>	<b>31</b>
<b>5.2.1 - UPLOAD, DOWNLOAD, FORMAT.....</b>	<b>31</b>
5.2.1.1 - MULTI FUNCTION KEY .....	32
5.2.1.2 - UNICARD.....	32
<b>5.2.2 - FIRMWARE BOOT LOADER.....</b>	<b>33</b>
<b>5.2.3 - KEYBOARD SHARED ON LINK<sup>2</sup> .....</b>	<b>33</b>
<b>5.3 - REGULATORS .....</b>	<b>34</b>
<b>5.3.1 - LINK<sup>2</sup> NETWORK .....</b>	<b>34</b>
5.3.1.1 - Supervision Gateway.....	34
5.3.1.2 - Shared temperature probe.....	35
5.3.1.3 - Defrost .....	36
5.3.1.4 - Shared display .....	38
5.3.1.5 - Shared setpoint value .....	39
5.3.1.6 - Shared commands .....	39
<b>5.3.2 - REGULATION.....</b>	<b>40</b>
5.3.2.1 - Standard regulation mode.....	40
5.3.2.2 - Double "series" thermostat.....	41
5.3.2.3 - Double "parallel" thermostat.....	41
5.3.2.4 - Two power step regulation.....	42
5.3.2.5 - Double compressor .....	43
5.3.2.6 - Auxiliary regulation.....	44
5.3.2.7 - Regulation in the event of a probe error .....	44
5.3.2.8 - Safety timing .....	44
5.3.2.9 - Energy Saving.....	45
5.3.2.10 - Dynamic Setpoint.....	45
5.3.2.11 - Remote Offset (managed by Supervisor only).....	46
<b>5.3.3 - COMPRESSOR/GENERAL PROTECTIONS .....</b>	<b>47</b>
5.3.3.1 - Compressor safety times .....	48
<b>5.3.4 - DEFROST/COIL DRAINAGE .....</b>	<b>49</b>
5.3.4.1 - Enable defrost .....	49
5.3.4.2 - Automatic defrost .....	50
5.3.4.3 - Manual defrost .....	50
5.3.4.4 - External Defrost.....	51
5.3.4.5 - Defrost mode.....	52
Defrost by electrical heater.....	52
Defrost by electrical heater: Smart Defrost.....	53
Reverse cycle defrost.....	54
Hot gas defrost for plug-in systems .....	55
Hot gas defrost for systems with remote unit.....	55
Double evaporator defrost.....	56
<b>5.3.5 - EVAPORATOR FANS .....</b>	<b>57</b>
5.3.5.1 - Operating conditions.....	57
5.3.5.2 - Fan function in temperature control.....	59
5.3.5.3 - Fan function in Duty Cycle.....	60
5.3.5.4 - Fan function during defrost.....	60
5.3.5.5 - Fan function without probe.....	61



5.3.5.6 - Fan function during dripping .....	61
5.3.5.7 - Post-ventilation .....	61
<b>5.3.6 - RTC.....</b>	<b>62</b>
5.3.6.1 - Weekdays/Weekends-Public Holidays .....	62
5.3.6.2 - Time-band defrost .....	62
5.3.6.3 - Periodical defrost .....	62
5.3.6.4 - Events.....	62
<b>5.3.7 - ENERGY SAVING .....</b>	<b>63</b>
5.3.7.1 - Virtual probe/ probe change.....	63
<b>5.3.8 - DEEP COOLING CYCLE (DCC) .....</b>	<b>64</b>
<b>5.3.9 - PREHEATING .....</b>	<b>64</b>
<b>5.3.10 - PRESSURE SWITCH.....</b>	<b>65</b>
<b>5.3.11 - AUXILIARY OUTPUT (AUX/LIGHT).....</b>	<b>66</b>
<b>5.3.12 - DOOR/EXTERNAL ALARM MANAGEMENT.....</b>	<b>67</b>
<b>5.3.13 - FRAME HEATER.....</b>	<b>69</b>
5.3.13.1 - Connection Examples.....	69
5.3.13.2 - Fixed value regulation .....	70
5.3.13.3 - Glass door probe regulation .....	70
5.3.13.4 - Regulation based on glass door probe with dew point from remote. ....	70
<b>5.3.14 - GENERAL INPUT.....</b>	<b>71</b>
<b>5.3.15 - STANDBY.....</b>	<b>71</b>
<b>6 - PARAMETERS TABLE.....</b>	<b>72</b>
<b>6.1 - PARAMETERS TABLE.....</b>	<b>72</b>
6.1.1 - "USER" MENU PARAMETERS TABLE .....	72
6.1.2 - "INSTALLER" MENU PARAMETERS TABLE .....	76
<b>7 - ALARMS TABLE.....</b>	<b>87</b>
<b>7.1 - ALARM AND MESSAGES TABLE .....</b>	<b>87</b>
7.1.1 - CAUSE/EFFECT TABLE .....	88
<b>7.2 - DESCRIPTION OF ALARMS .....</b>	<b>90</b>
7.2.1 - PROBE ALARM .....	90
7.2.2 - MINIMUM AND MAXIMUM TEMPERATURE ALARM.....	91
7.2.3 - END OF DEFROST ALARM DUE TO TIME-OUT.....	92
7.2.4 - EXTERNAL ALARM .....	92
7.2.5 - DOOR OPEN ALARM .....	93
7.2.6 - PRESSURE SWITCH INPUT ALARM .....	94
<b>8 - MODBUS MSK 509 FUNCTIONS AND RESOURCES .....</b>	<b>95</b>
<b>8.1 - DATA FORMAT (RTU) .....</b>	<b>95</b>
8.1.2 - MODBUS COMMANDS AVAILABLE AND DATA AREAS.....	96
8.1.3 - ADDRESS CONFIGURATION.....	96
8.1.4 - PARAMETER VISIBILITY AND VALUES .....	96
<b>8.2 - MODBUS TABLES.....</b>	<b>97</b>
8.2.1 - PARAMETER/VISIBILITY TABLE .....	99
8.2.2 - FOLDER VISIBILITY TABLE .....	139
8.2.3 - TABELLA CLIENT .....	139



---

<b>9 - WARNINGS</b> .....	<b>141</b>
9.1 - ELECTRICAL CONNECTIONS.....	141
9.2 - DISCLAIMER.....	141
9.3 - RESPONSIBILITIES AND RESIDUAL RISKS.....	141
9.4 - CONDITIONS OF USE .....	141
<b>A - APPENDIX</b> .....	<b>142</b>
LVD - POWER SUPPLY CONTROL.....	142

# 1 - INTRODUCTION



**RTX600-RTN600** series is a series of controllers for freezer cabinets and cold rooms with built-in compressors.

## 1.1 - MAIN FEATURES

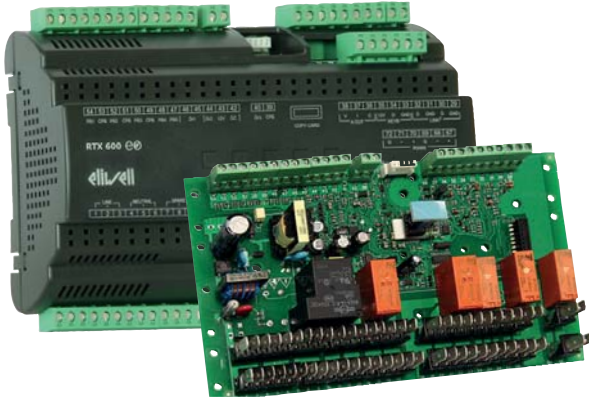

- DIN rail (**RTX600**) or panel-mounted (**RTN600**)
- Energy-saving algorithms
- 8 pre-loaded applications
- Single defrost / double evaporator
- Frame heater
- Self-configuration of the LAN
- Direct load connection
- 2-step management of 1 compressor or single-step management of 2 compressors
- LVD power supply control (**OPTIONAL** - see "Appendix")
- Easy to refit in Eliwell and third-party systems

## 1.2 - DESCRIPTION

This latest generation device has the following key functions:

- 2 ON/OFF regulators for HOT/COLD
- Single defrost and double evaporator (heatings, modulated heaters, reverse cycle, hot gas)
- Evaporator fans
- Anti-sweat heater (Frame Heater)
- AUX
- Light
- Door switch
- ON /OFF
- Deep cooling cycle
- Dynamic setpoint
- Day / Night
- Diagnostics
- "Easy Map" programming
- Programmable inputs/outputs
- LINK<sup>2</sup> local area network
- RS485 communication protocols: Modbus and Televis
- Compatible with Device Manager (DM)
- Compatible with Unicard and Multi-function key

## 2 - SPECIFICATIONS



### 2.1 - TECHNICAL SPECIFICATIONS (EN 60730-2-9)

Classification:	electronic automatic control (not safety) device for incorporation
Mounting:	DIN rail.
Type of action:	1.B
Pollution class:	2
Material class:	IIIa
Overvoltage category:	II
Nominal pulse voltage:	2500V
Temperature:	Use: -5 ... +55°C - Storage: -30 ... +85°C
Power supply:	SMPS 100-240V~ ±10% 50/60 Hz
Power consumption:	7.5W max
Fire resistance category:	D
Software class:	A
RTC battery life:	In absence of external power, the clock battery will last 4 days.

### 2.2 - FURTHER INFORMATION

#### 2.2.1 - INPUT CHARACTERISTICS

Measurement range:	<b>NTC:</b> -50.0°C ... +110°C; <b>PTC:</b> -55.0°C ... +150°C; <b>PT1000:</b> -60.0°C ... +150°C (on 3-digit display with +/- sign)
Accuracy:	±1.0° for temperatures below -30°C ±0.5° for temperatures between -30°C and +25°C ±1.0° for temperatures above +25°C
Resolution:	1 or 0.1°C
Buzzer:	NO
Analogue/Digital Inputs:	5 configurable NTC/PTC/PT1000/DI inputs 3 multi-function, voltage-free digital inputs (DI)

#### 2.2.2 - OUTPUT CHARACTERISTICS

Digital Outputs:	<b>OUT1:</b> 1 SPST relay: 2HP max 240V~ <b>OUT2:</b> 1 SPST relay: 1HP max 250V~ <b>OUT3:</b> 1 SPDT relay: 1HP max 250V~ <b>OUT4:</b> 1 SPDT relay: 8(4)A max 250V~ <b>OUT5:</b> 1 SPST relay: 8(4)A max 250V~ <b>OUT6:</b> 1 SPST relay: 8(4)A max 250V~
OC (Open Collector) Output:	<b>OC:</b> 1 multifunctional output: 12V= 20mA
DAC output:	<b>A-OUT:</b> 1 multifunctional output: 0...10V / 4...20mA

#### 2.2.3 - MECHANICAL CHARACTERISTICS

Container:	PC+ABS resin casing, UL94 V-0
Dimensions:	10 DIN-rail
Terminals:	disconnectable ( <b>RTX600</b> ) or screw ( <b>RTN600</b> ) for wires with cross-section of 2.5mm <sup>2</sup>
Connectors:	TTL for Unicard / Device Manager connection (via DMI)
Humidity:	Usage / Storage: 10...90% RH (non-condensing)

#### 2.2.4 - REGULATIONS

Electromagnetic compatibility:	The device complies with Directive 2004/108/EC
Safety:	The device complies with Directive 2006/95/EC
Food Safety:	The device complies with standard EN13485 as follows: <ul style="list-style-type: none"><li>- Suitable for storage.</li><li>- Application: air.</li><li>- Climate range A</li><li>- measurement class 1 in the range from -25°C to 15°C (*)</li></ul>

(\* only Eliwell probes must be used)

**NOTE:** The technical specifications stated in this document regarding the measurement (range, accuracy, resolution, etc.) refer strictly to the instrument and not to any accessories provided, such as the probes. This means, for example, that the error introduced by the probe must be added to the error of the instrument.



## 2.3 - CONNECTIONS

### 2.3.1 - RTX600 TERMINALS

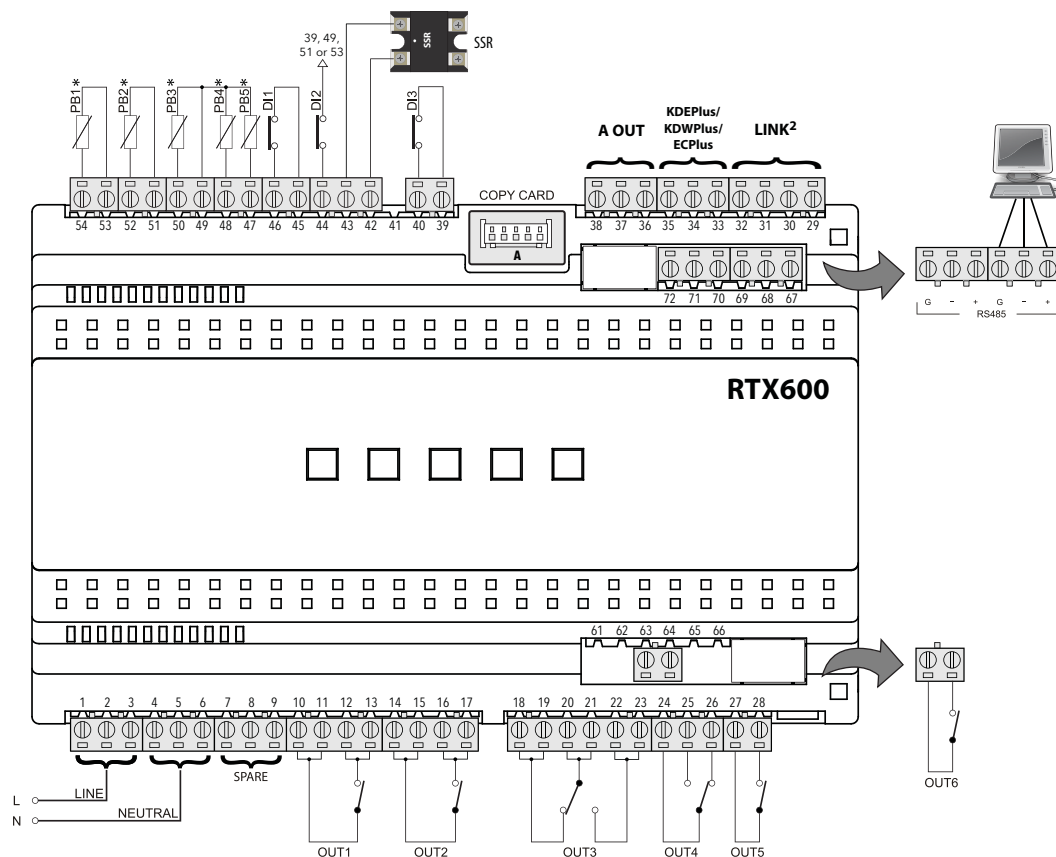

\* **N.B.:** analogue inputs PB1...PB5 can also be configured as Digital Inputs DI.

TERMINALS			
1-2-3	LINE. These are power supply terminals.	29-30	LINK <sup>2</sup> . Connection 1 - local area network.
4-5-6	NEUTRAL. These are power supply terminals.	31-32	LINK <sup>2</sup> . Connection 2 - local area network.
7-8-9	SPARE. These are supporting terminals that are not connected internally.	33-34-35	Connection to KDEPlus or KDWPlus external keyboard or ECPlus echo module.
10-11	OUT1 Shared Terminal	36-38	A OUT. 0-10V DAC analogue voltage output
12-13	N.O. OUT1	36-37	A OUT. Analogue current output (4...20mA).
14-15	OUT2 Shared Terminal	A	TTL Unicard/DMI/Multi Function Key connection
16-17	N.O. OUT2	39-40	Digital input DI3
18-19	N.C. OUT3	43-42	Open Collector Output (OC).
20-21	OUT3 Shared Terminal	44-CPB	Digital input DI2 (CPB = 39, 49, 51 or 53)
22-23	N.O. OUT3	45-46	Digital input DI1
24	OUT4 Shared Terminal	49-47	PB5 probe connection.
25	N.O. OUT4	49-48	PB4 probe connection.
26	N.C. OUT4	49-50	PB3 probe connection.
27	OUT5 Shared Terminal	51-52	PB2 probe connection.
28	N.O. OUT5	53-54	PB1 probe connection.
63	OUT6 Shared Terminal	67-68-69	RS485. Connection 1 - Supervision Gateway
64	N.O. OUT6	70-71-72	RS485. Connection 2 - Supervision Gateway





## 2.3.2 - RTN600 TERMINALS

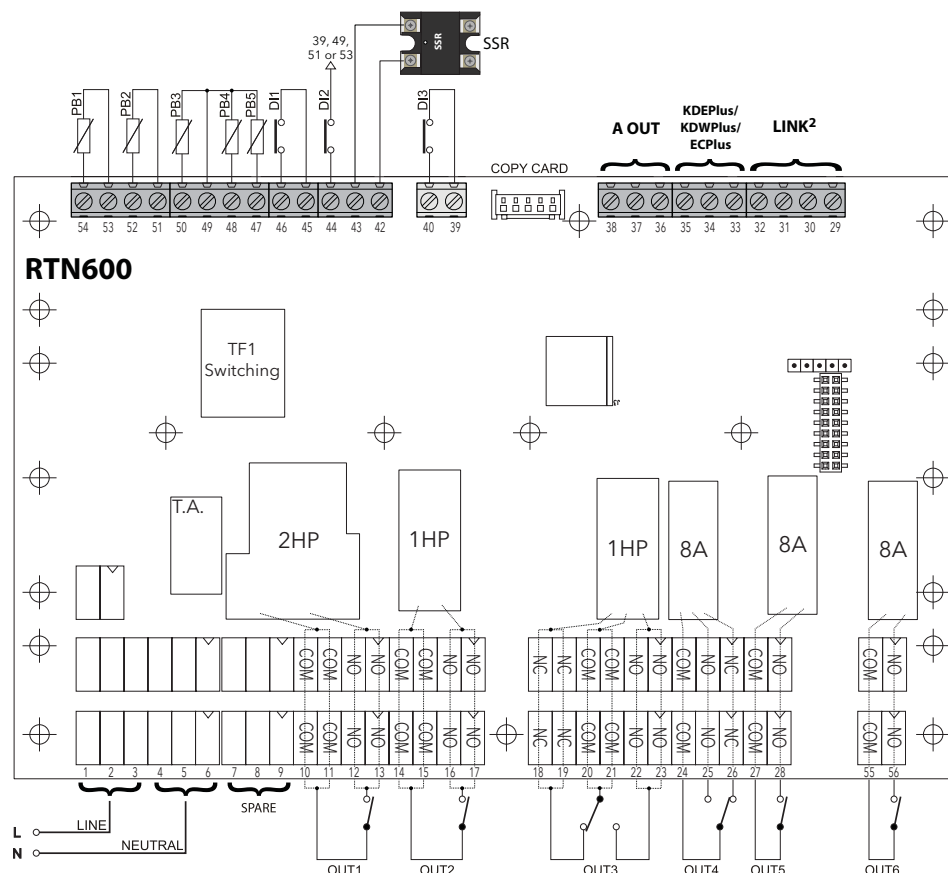

\* **N.B.:** analogue inputs PB1...PB5 can also be configured as Digital Inputs DI.

TERMINALS			
<b>1-2-3</b>	LINE. These are power supply terminals.	<b>29-30</b>	LINK <sup>2</sup> . Connection 1 - local area network.
<b>4-5-6</b>	NEUTRAL. These are power supply terminals.	<b>31-32</b>	LINK <sup>2</sup> . Connection 2 - local area network.
<b>7-8-9</b>	SPARE: These are supporting terminals that are not connected internally.	<b>33-34-35</b>	Connection to KDEPlus or KDWPlus external keyboard or ECPlus echo module.
<b>10-11</b>	OUT1 Shared Terminal	<b>36-38</b>	A OUT. 0-10V DAC analogue voltage output
<b>12-13</b>	N.O. OUT1	<b>36-37</b>	A OUT. Analogue current output (4...20mA).
<b>14-15</b>	OUT2 Shared Terminal	<b>A</b>	TTL Unicard/DMI/Multi Function Key connection
<b>16-17</b>	N.O. OUT2	<b>39-40</b>	Digital input DI3
<b>18-19</b>	N.C. OUT3	<b>43-42</b>	Open Collector Output (OC).
<b>20-21</b>	OUT3 Shared Terminal	<b>44-CPB</b>	Digital input DI2 (CPB = 39, 49, 51 or 53)
<b>22-23</b>	N.O. OUT3	<b>45-46</b>	Digital input DI1
<b>24</b>	OUT4 Shared Terminal	<b>49-47</b>	PB5 probe connection.
<b>25</b>	N.O. OUT4	<b>49-48</b>	PB4 probe connection.
<b>26</b>	N.C. OUT4	<b>49-50</b>	PB3 probe connection.
<b>27</b>	OUT5 Shared Terminal	<b>51-52</b>	PB2 probe connection.
<b>28</b>	N.O. OUT5	<b>53-54</b>	PB1 probe connection.
<b>55</b>	OUT6 Shared Terminal		
<b>56</b>	N.O. OUT6		



### 2.3.3 - CONNECTING A D.I. TO PB1...PB7 INPUTS

A D.I. can be connected to **PB1...PB5** inputs by connecting it between pin **PBx** (with  $x = 1, 2, 3, 4$  or  $5$ ) and the relative earth pin (**CPB**). Here's an example of how to connect the various D.I.s:

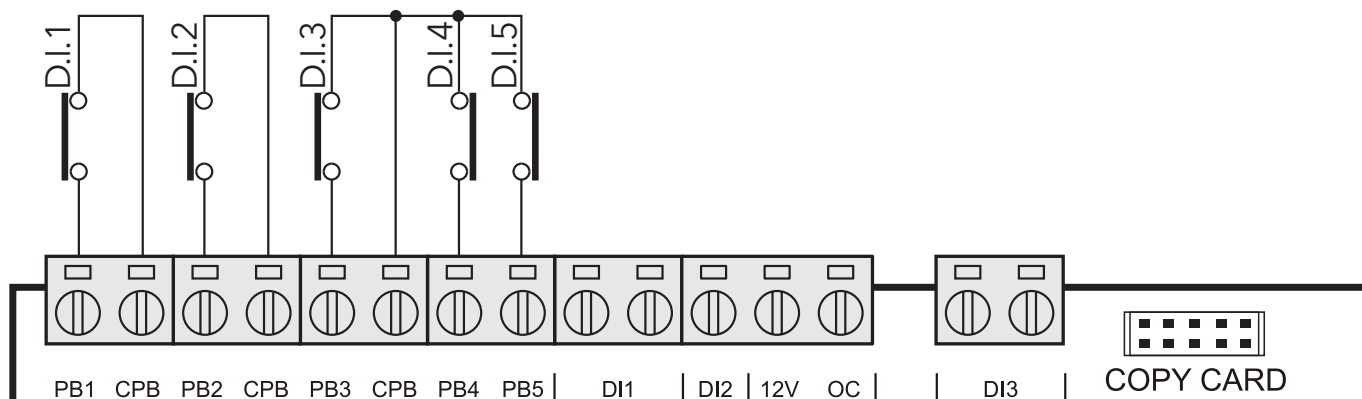

## RTX600

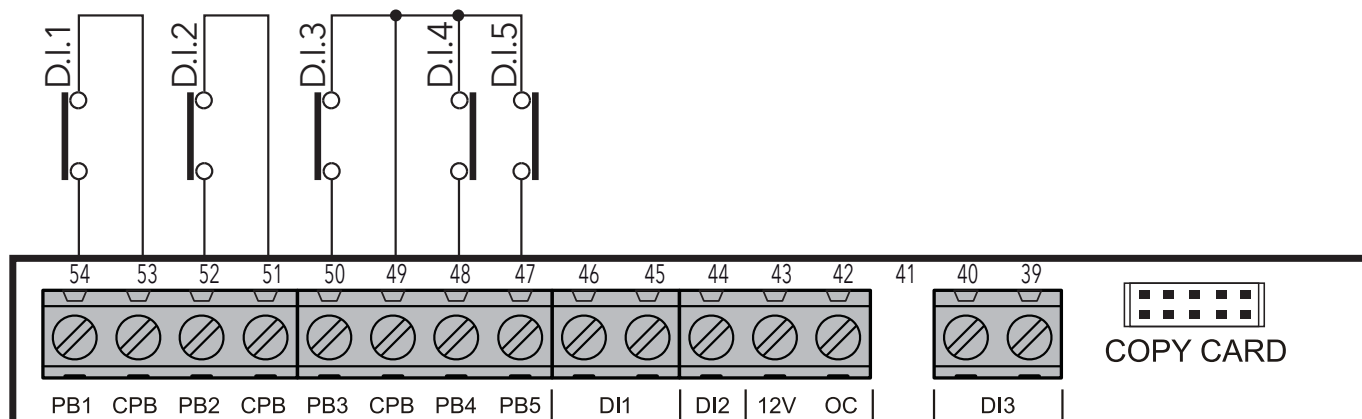

## RTN600



### 3 - APPLICATIONS



#### 3.1 - SUMMARY

FUNCTION	AP1	AP2	AP3	AP4	AP5	AP6	AP7	AP8
<b>INPUTS</b>								
<b>PB1</b> (NTC)	<b>VIRT1*</b>	<b>REG1</b>	<b>REG1</b>	<b>REG1</b>	<b>REG1</b>	<b>REG1</b>	<b>REG1</b>	<b>REG1</b>
<b>PB2</b> (NTC)	<b>VIRT2*</b>				<b>REG2**</b>			
<b>PB3</b> (NTC)			/	/	/	/	/	
<b>PB4</b> (NTC)								Frame Heater 0...10V output
<b>PB5</b> (digital input)								
<b>DI1</b> (par. H18)								
<b>DI2</b> (par. H16)								
<b>DI3</b> (par. H17)								
<b>OUTPUTS</b>								
<b>OUT1</b> (16A relay)								
<b>OUT2</b> (16A relay)								
<b>OUT3</b> (16A relay)								
<b>OUT4</b> (8A relay)	(AUX)							
<b>OUT5</b> (8A relay)								
<b>OUT6</b> (8A relay)								
<b>DAC</b>								Frame Heater 0...10V output
<b>OC</b>	Frame Heater	Frame Heater	Frame Heater	Frame Heater	Frame Heater		Frame Heater	

**N.B.:**

\* : regulation with virtual probe occurs on the value  $P_{bi} = [\mathbf{VIRT1} \times H72 + \mathbf{VIRT2} \times (100 - H72)]/100$  (where **VIRT1** = value of temperature probe selected with H70 and **VIRT2** = value of temperature probe selected with H71)

\*\* : Thermostat 2 control probe (compressor ON when both thermostats are requested, otherwise OFF).



## DESCRIPTION OF APPLICATIONS

### **AP1 (Dairy Products and Fruit/Vegetables):**

MV vertical open display cabinet - resistance defrost.

### **AP2 (Frozen Foods):**

LV vertical glass door cabinet - resistance defrost.

### **AP2 (Frozen Foods):**

LV island - single evaporator - resistance defrost.

### **AP4 (Frozen Foods):**

TN Glass Door Cabinet - single evaporator - resistance defrost.

### **AP5 (Frozen Foods):**

BT/BT Combi - single evaporator.

### **AP6 (Frozen Foods and Fruit/Vegetables):**

Cold Room.

### **AP7 (Frozen Foods):**

LV island - single evaporator - hot gas defrost (Plug-in).

### **AP8 (Frozen Foods):**

LV vertical glass door cabinet - resistance defrost - frame heater with probe.

## Control

Depending on the application selected, the **RTX600-RTN600** regulates as follows:

- Standard Regulation (AP1-AP2-AP3-AP4-AP6-AP7-AP8).  
The regulator will activate when the temperature exceeds  $T > SP1 + dF1$  and disables when  $T < SP1$ .  
For these applications, the regulation differential is managed as a relative value.
- Double "parallel" thermostat (AP5).  
Regulation is based on 2 thermostats (T1 and T2) connected "in parallel".  
This regulator activates cold only if both thermostats have been requested, and disables it when both thermostats have been satisfied. If one or both of the thermostats has a probe error, the regulation will use the probe error parameters.



### 3.2 - APPLICATION 1

The application is configured for "VERTICAL OPEN DISPLAY CABINETS" at average temperature values and resistance defrost, recommended for the storage of dairy products and fruit/vegetables. The preset configuration features:

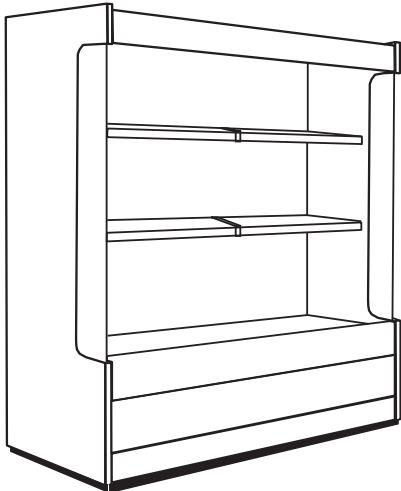
APPLICATION	APPLICATION DATA
	<p><b>Settings for Inputs, Outputs and Keys are listed below:</b></p> <p><b>Input Configuration:</b></p> <ul style="list-style-type: none"> <li>• Input PB1 = virtual sensor VIRT1*</li> <li>• Input PB2 = virtual sensor VIRT2*</li> <li>• Input PB3 = evaporator sensor</li> <li>• Input PB4 = not set</li> <li>• Input PB5 = not set</li> <li>• Input DI1 = not set</li> <li>• Input DI2 = not set</li> <li>• Input DI3 = not set</li> </ul> <p><b>Output Configuration:</b></p> <ul style="list-style-type: none"> <li>• OUT1 (16A relay) = compressor</li> <li>• OUT2 (16A relay) = evaporator fans</li> <li>• OUT3 (16A relay) = Defrost 1</li> <li>• OUT4 (8A relay) = AUX (screen)</li> <li>• OUT5 (8A relay) = light</li> <li>• OUT6 (8A relay) = alarm</li> <li>• DAC = not set</li> <li>• OC = Frame Heater</li> </ul> <p><b>Key configuration:</b></p> <ul style="list-style-type: none"> <li>• UP key = manual defrost</li> <li>• DOWN key = not set</li> <li>• ESC key = stand-by</li> </ul> <p>* regulated via virtual probe on the basis of value</p> $Pbi = [VIRT1 \times H72 + VIRT2 \times (100 - H72)]/100$ <p>where: - VIRT1 = value of temperature probe selected with H70          - VIRT2 = value of temperature probe selected with H71</p>

#### APPLICATION DIAGRAM

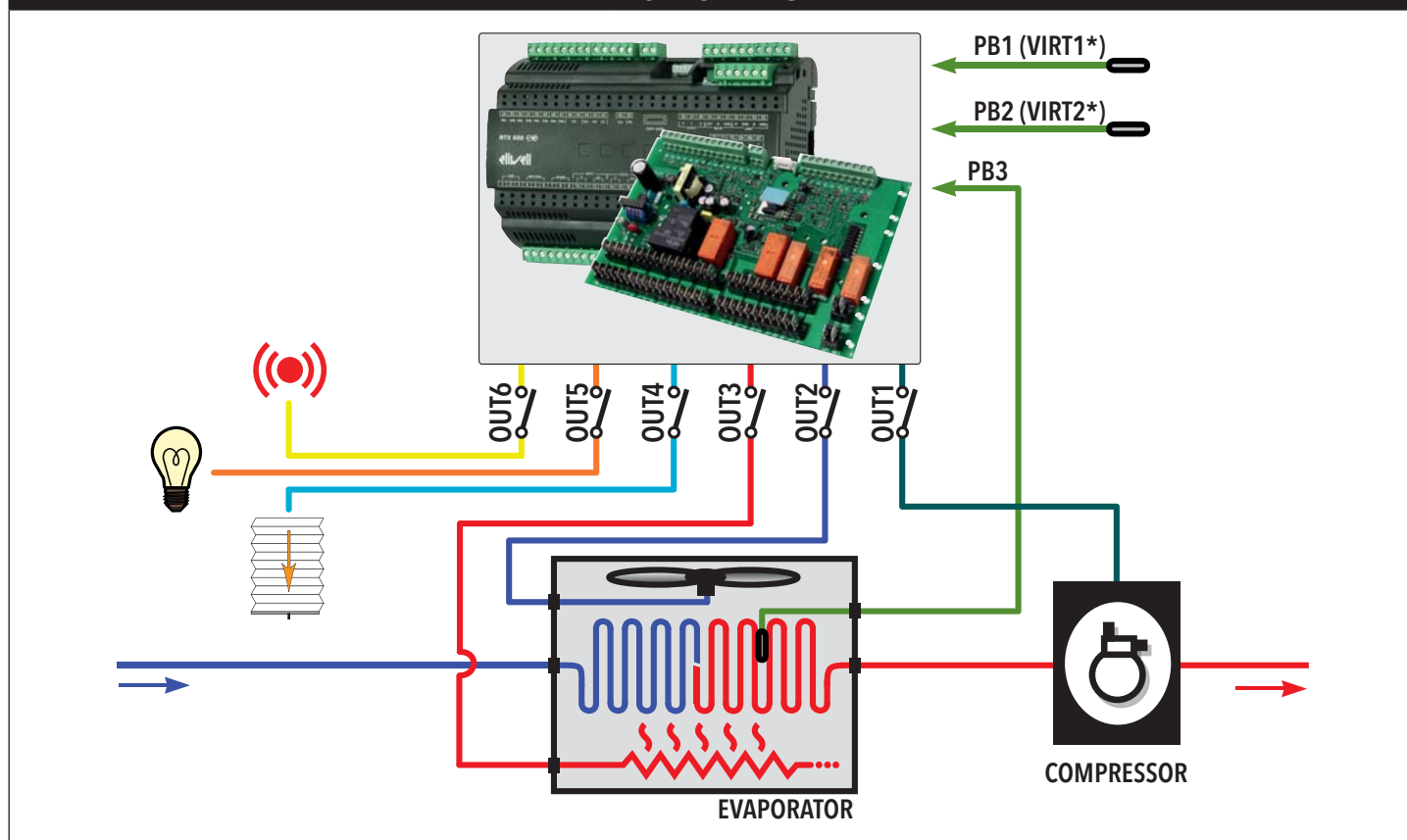



### 3.3 - APPLICATION 2

The application is configured for "VERTICAL GLASS DOOR DISPLAY CABINETS" at low temperature values and resistance defrost, recommended for the storage of frozen foods. The preset configuration features:

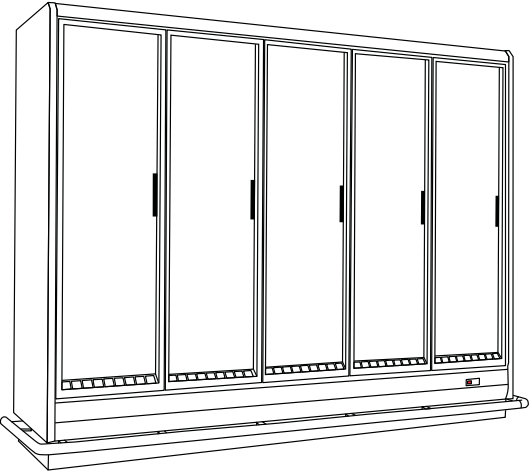
APPLICATION	APPLICATION DATA
	<p><b>Settings for Inputs, Outputs and Keys are listed below:</b></p> <p><b>Input Configuration:</b></p> <ul style="list-style-type: none"> <li>• Input PB1 = regulator sensor REG1</li> <li>• Input PB2 = not set</li> <li>• Input PB3 = evaporator sensor</li> <li>• Input PB4 = not set</li> <li>• Input PB5 = not set</li> <li>• Input DI = door switch</li> <li>• Input DI2 = not set</li> <li>• Input DI3 = not set</li> </ul> <p><b>Output Configuration:</b></p> <ul style="list-style-type: none"> <li>• OUT1 (16A relay) = compressor</li> <li>• OUT2 (16A relay) = evaporator fans</li> <li>• OUT3 (16A relay) = Defrost 1</li> <li>• OUT4 (8A relay) = alarm</li> <li>• OUT5 (8A relay) = light</li> <li>• OUT6 (8A relay) = not set</li> <li>• DAC = not set</li> <li>• OC = Frame Heater</li> </ul> <p><b>Key configuration:</b></p> <ul style="list-style-type: none"> <li>• UP key = manual defrost</li> <li>• DOWN key = not set</li> <li>• ESC key = stand-by</li> </ul>

#### APPLICATION DIAGRAM

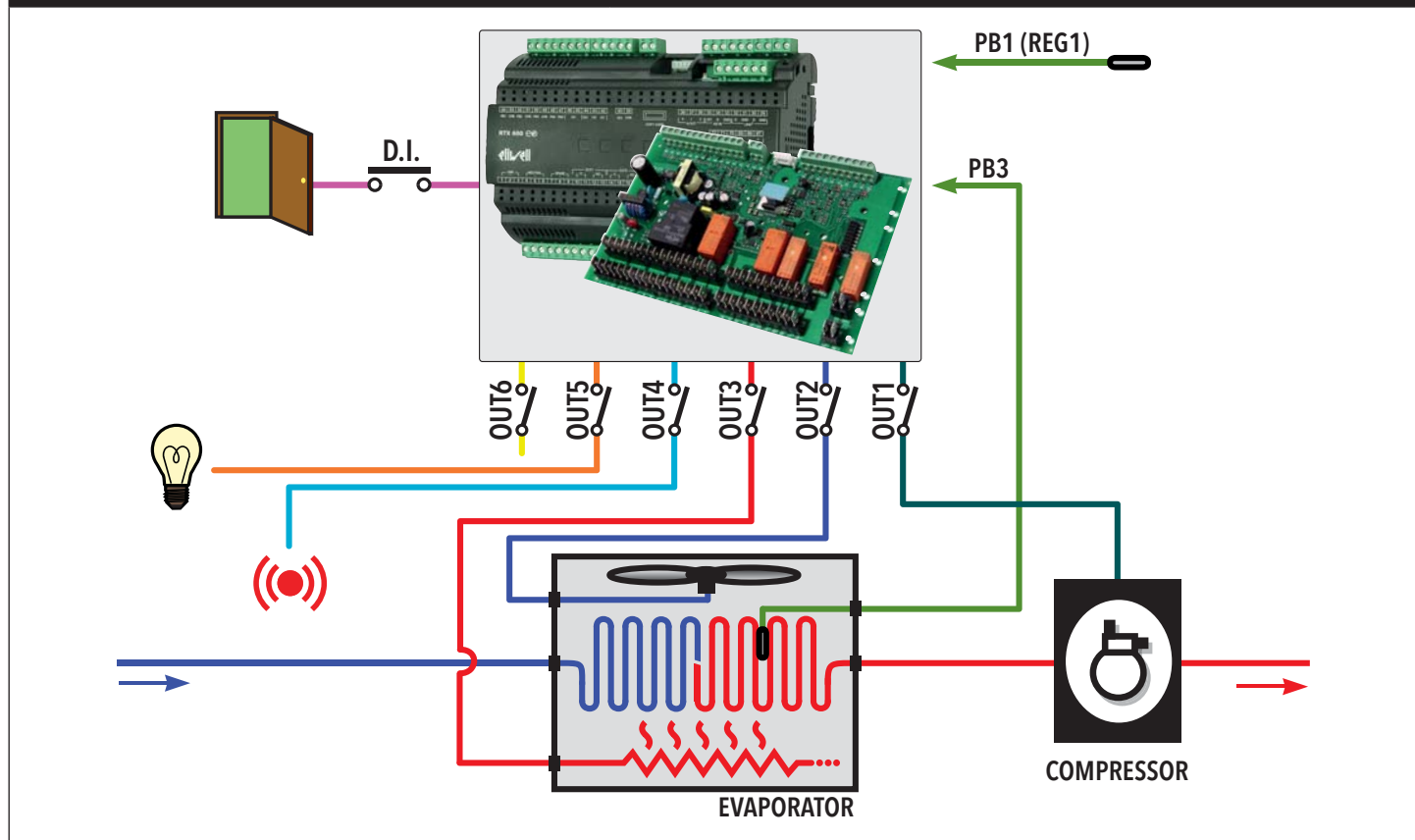



### 3.4 - APPLICATION 3

The application is configured for "HORIZONTAL ISLANDS" at low temperature values, single evaporator and resistance defrost, recommended for the storage of frozen foods. The preset configuration features:

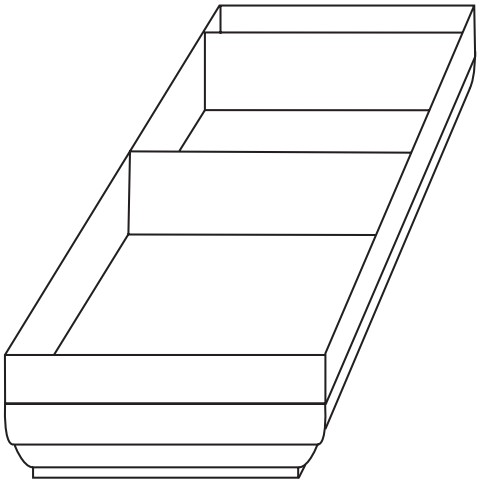
APPLICATION	APPLICATION DATA
	<p><b>Settings for Inputs, Outputs and Keys are listed below:</b></p> <p><b>Input Configuration:</b></p> <ul style="list-style-type: none"> <li>• Input PB1 = regulator sensor REG1</li> <li>• Input PB2 = not set</li> <li>• Input PB3 = evaporator/fan sensor</li> <li>• Input PB4 = not set</li> <li>• Input PB5 = not set</li> <li>• Input DI1 = not set</li> <li>• Input DI2 = not set</li> <li>• Input DI3 = not set</li> </ul> <p><b>Output Configuration:</b></p> <ul style="list-style-type: none"> <li>• OUT1 (16A relay) = compressor</li> <li>• OUT2 (16A relay) = evaporator fans</li> <li>• OUT3 (16A relay) = Defrost 1</li> <li>• OUT4 (8A relay) = alarm</li> <li>• OUT5 (8A relay) = light</li> <li>• OUT6 (8A relay) = not set</li> <li>• DAC = not set</li> <li>• OC = Frame Heater</li> </ul> <p><b>Key configuration:</b></p> <ul style="list-style-type: none"> <li>• UP key = manual defrost</li> <li>• DOWN key = not set</li> <li>• ESC key = stand-by</li> </ul>

#### APPLICATION DIAGRAM

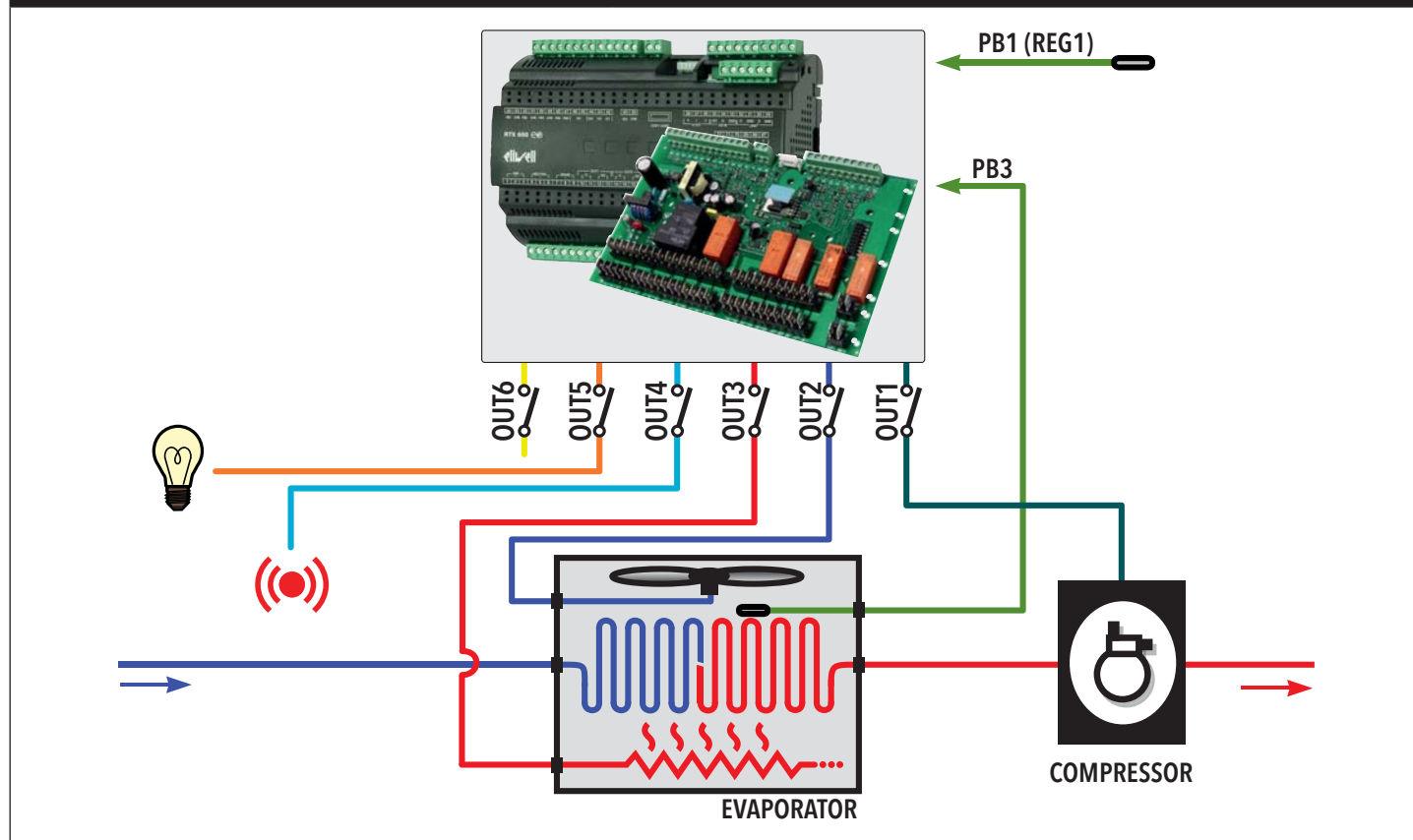





### 3.5 - APPLICATION 4

The application is configured for "GLASS DOOR CABINETS" at normal temperature values, single evaporator and resistance defrost, recommended for foodstuffs. The preset configuration features:

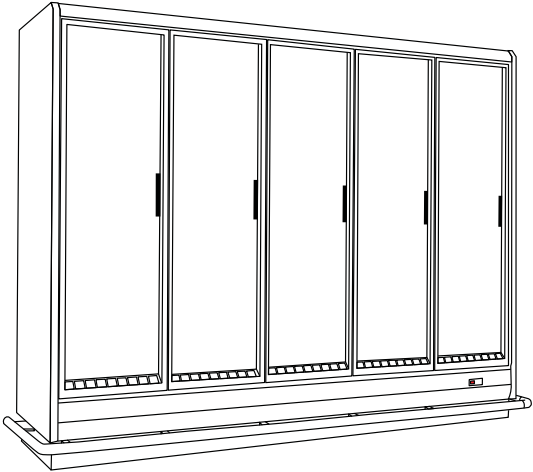
APPLICATION	APPLICATION DATA
	<p><b>Settings for Inputs, Outputs and Keys are listed below:</b></p> <p><b>Input Configuration:</b></p> <ul style="list-style-type: none"> <li>• Input PB1 = regulator sensor REG1</li> <li>• Input PB2 = not set</li> <li>• Input PB3 = evaporator1/fan sensor</li> <li>• Input PB4 = not set</li> <li>• Input PB5 = not set</li> <li>• Input DI1 = not set</li> <li>• Input DI2 = not set</li> <li>• Input DI3 = not set</li> </ul> <p><b>Output Configuration:</b></p> <ul style="list-style-type: none"> <li>• OUT1 (16A relay) = compressor</li> <li>• OUT2 (16A relay) = evaporator fans</li> <li>• OUT3 (16A relay) = Defrost 1</li> <li>• OUT4 (8A relay) = alarm</li> <li>• OUT5 (8A relay) = light</li> <li>• OUT6 (8A relay) = not set</li> <li>• DAC = not set</li> <li>• OC = Frame Heater</li> </ul> <p><b>Key configuration:</b></p> <ul style="list-style-type: none"> <li>• UP key = manual defrost</li> <li>• DOWN key = not set</li> <li>• ESC key = stand-by</li> </ul>

#### APPLICATION DIAGRAM

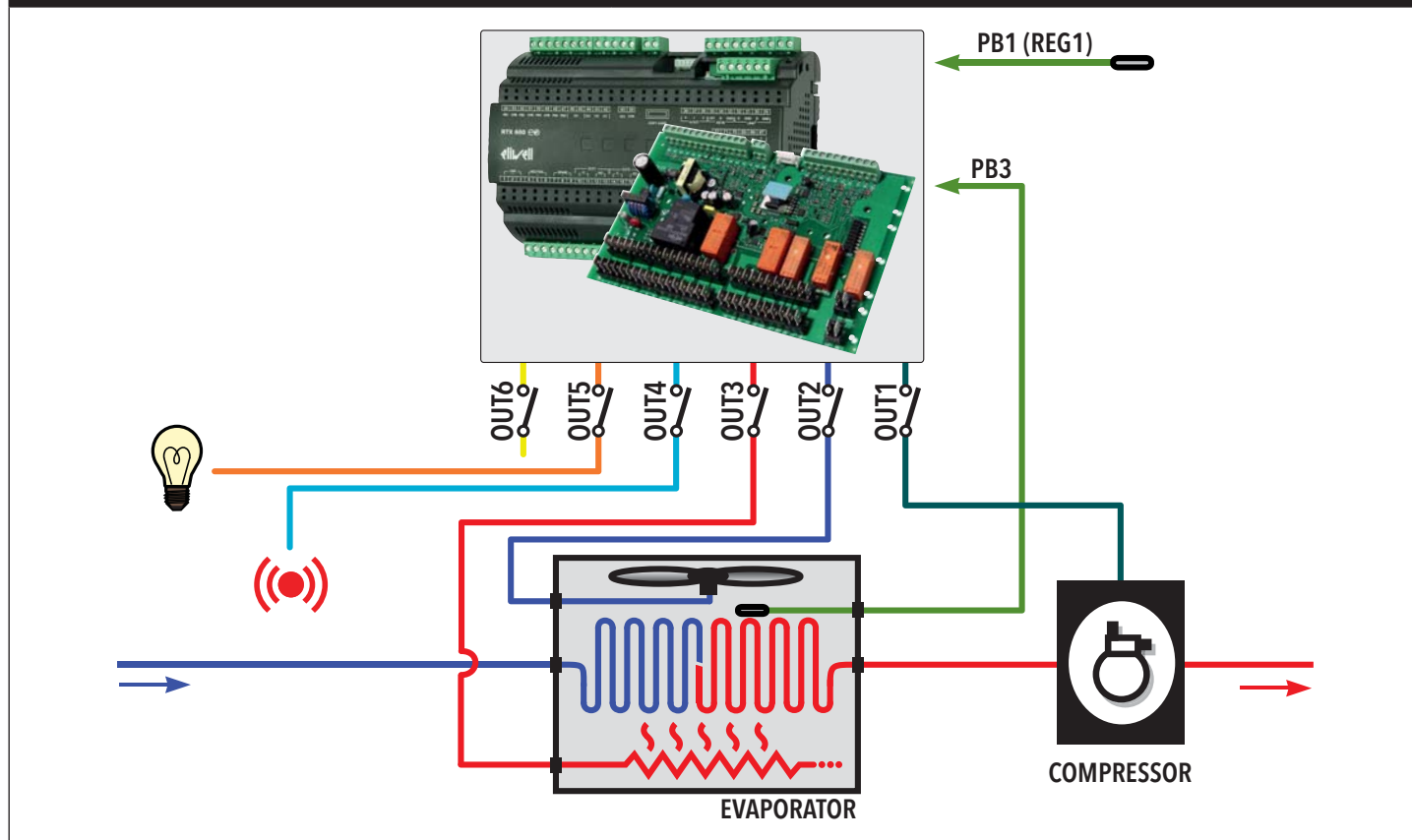



### 3.6 - APPLICATION 5

The application is configured for "COMBINED VERTICAL DISPLAY CABINETS" at low temperature values, single evaporator and resistance defrost, recommended for the storage of frozen foods. The preset configuration features:

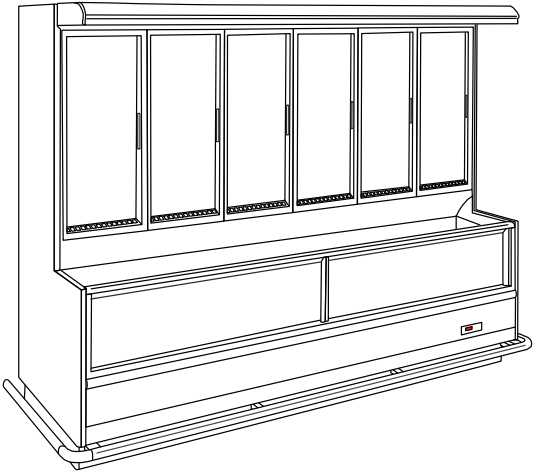
APPLICATION	APPLICATION DATA
	<p><b>Settings for Inputs, Outputs and Keys are listed below:</b></p> <p><b>Input Configuration:</b></p> <ul style="list-style-type: none"> <li>• Input PB1 = regulator sensor REG1</li> <li>• Input PB2 = regulator sensor REG2*</li> <li>• Input PB3 = evaporator/fan sensor</li> <li>• Input PB4 = not set</li> <li>• Input PB5 = not set</li> <li>• Input DI1 = not set</li> <li>• Input DI2 = not set</li> <li>• Input DI3 = not set</li> </ul> <p><b>Output Configuration:</b></p> <ul style="list-style-type: none"> <li>• OUT1 (16A relay) = compressor</li> <li>• OUT2 (16A relay) = evaporator fans</li> <li>• OUT3 (16A relay) = Defrost 1</li> <li>• OUT4 (8A relay) = alarm</li> <li>• OUT5 (8A relay) = light</li> <li>• OUT6 (8A relay) = not set</li> <li>• DAC = not set</li> <li>• OC = Frame Heater</li> </ul> <p><b>Key configuration:</b></p> <ul style="list-style-type: none"> <li>• UP key = manual defrost</li> <li>• DOWN key = not set</li> <li>• ESC key = stand-by</li> </ul> <p>* Thermostat 2 control probe (compressor ON when both thermostats are requested, otherwise OFF).</p>

#### APPLICATION DIAGRAM

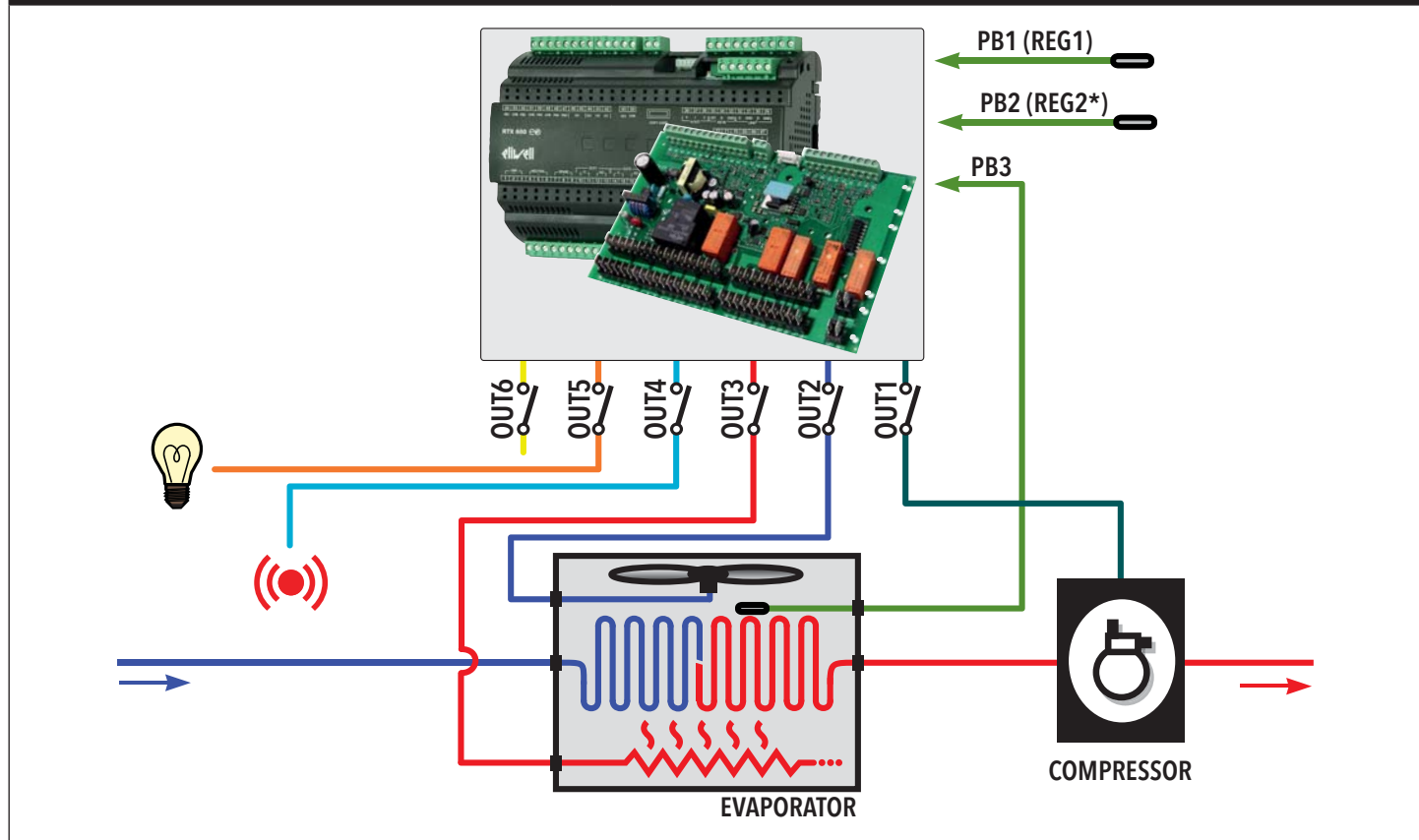



### 3.7 - APPLICATION 6

The application is configured for "COLD ROOMS" recommended for the storage of frozen foods and fruit/vegetables. The preset configuration features:

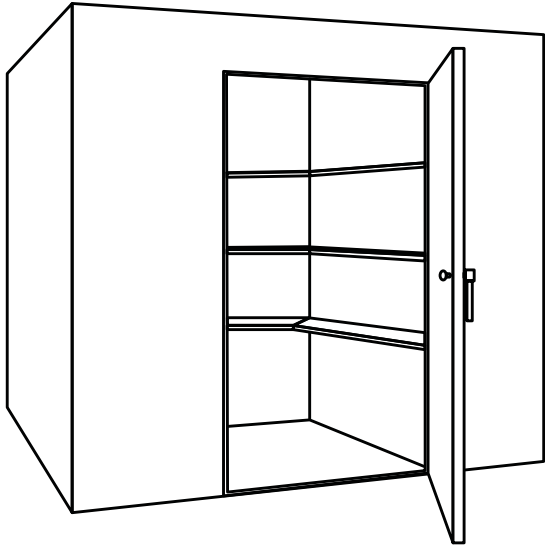
APPLICATION	APPLICATION DATA
	<p><b>Settings for Inputs, Outputs and Keys are listed below:</b></p> <p><b>Input Configuration:</b></p> <ul style="list-style-type: none"> <li>• Input PB1 = regulator sensor REG1</li> <li>• Input PB2 = not set</li> <li>• Input PB3 = evaporator/fan sensor</li> <li>• Input PB4 = not set</li> <li>• Input PB5 = not set</li> <li>• Input DI = door switch</li> <li>• Input DI2 = not set</li> <li>• Input DI3 = not set</li> </ul> <p><b>Output Configuration:</b></p> <ul style="list-style-type: none"> <li>• OUT1 (16A relay) = compressor</li> <li>• OUT2 (16A relay) = evaporator fans</li> <li>• OUT3 (16A relay) = Defrost 1</li> <li>• OUT4 (8A relay) = alarm</li> <li>• OUT5 (8A relay) = light</li> <li>• OUT6 (8A relay) = not set</li> <li>• DAC = not set</li> <li>• OC = not set</li> </ul> <p><b>Key configuration:</b></p> <ul style="list-style-type: none"> <li>• UP key = manual defrost</li> <li>• DOWN key = not set</li> <li>• ESC key = stand-by</li> </ul>

#### APPLICATION DIAGRAM

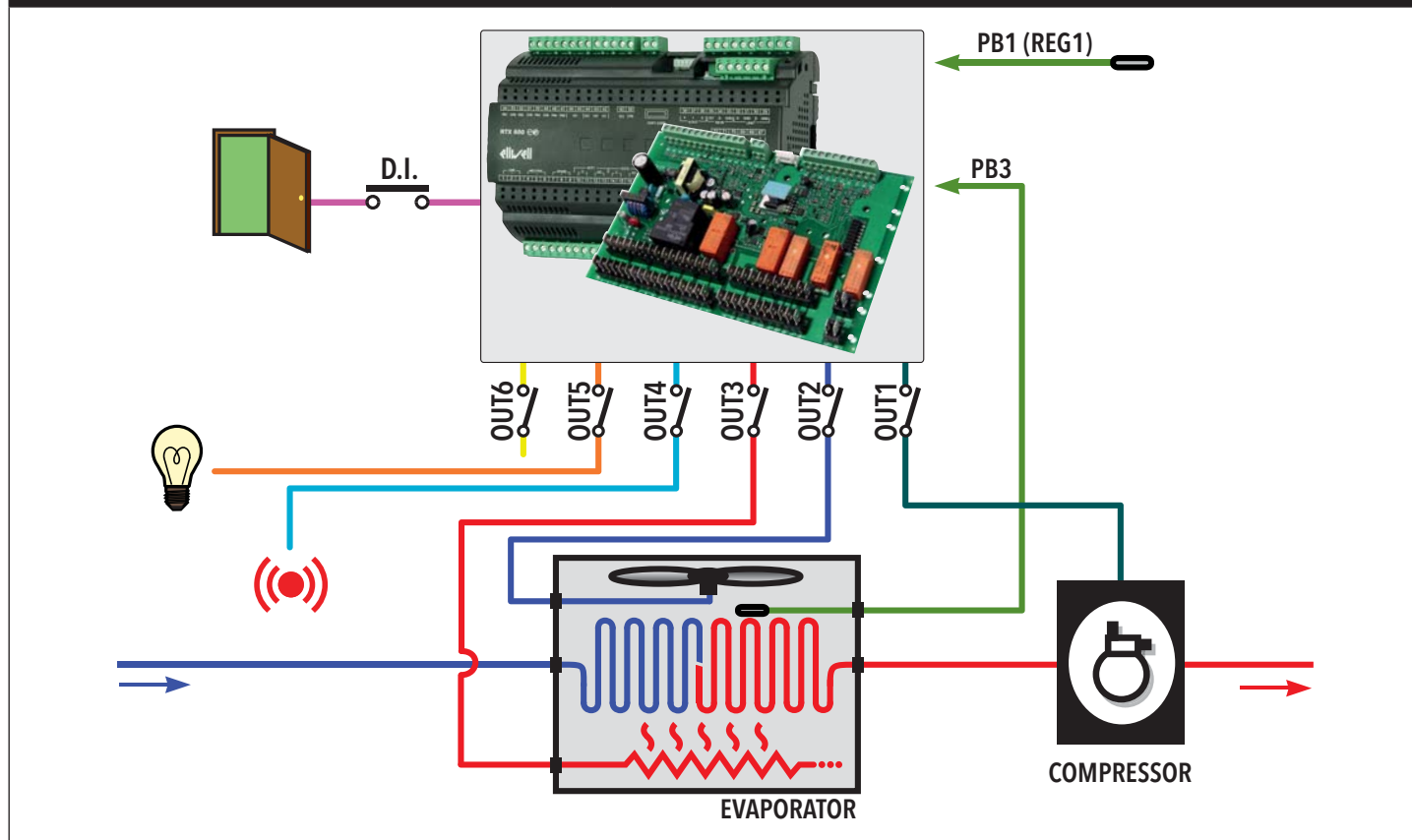



### 3.8 - APPLICATION 7

The application is configured for "HORIZONTAL ISLANDS" at low temperature values, single evaporator and hot gas defrost, recommended for the storage of frozen foods. The preset configuration features:

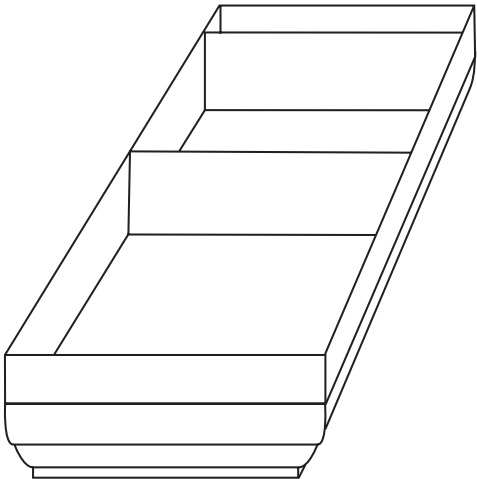
APPLICATION	APPLICATION DATA
	<p><b>Settings for Inputs, Outputs and Keys are listed below:</b></p> <p><b>Input Configuration:</b></p> <ul style="list-style-type: none"> <li>• Input PB1 = regulator sensor REG1</li> <li>• Input PB2 = not set</li> <li>• Input PB3 = evaporator sensor</li> <li>• Input PB4 = not set</li> <li>• Input PB5 = not set</li> <li>• Input DI1 = not set</li> <li>• Input DI2 = not set</li> <li>• Input DI3 = not set</li> </ul> <p><b>Output Configuration:</b></p> <ul style="list-style-type: none"> <li>• OUT1 (16A relay) = compressor</li> <li>• OUT2 (16A relay) = evaporator fans</li> <li>• OUT3 (16A relay) = Defrost 1</li> <li>• OUT4 (8A relay) = alarm</li> <li>• OUT5 (8A relay) = light</li> <li>• OUT6 (8A relay) = hot gas on evaporator suction valve</li> <li>• DAC = not set</li> <li>• OC = Frame Heater</li> </ul> <p><b>Key configuration:</b></p> <ul style="list-style-type: none"> <li>• UP key = manual defrost</li> <li>• DOWN key = not set</li> <li>• ESC key = stand-by</li> </ul>

#### APPLICATION DIAGRAM

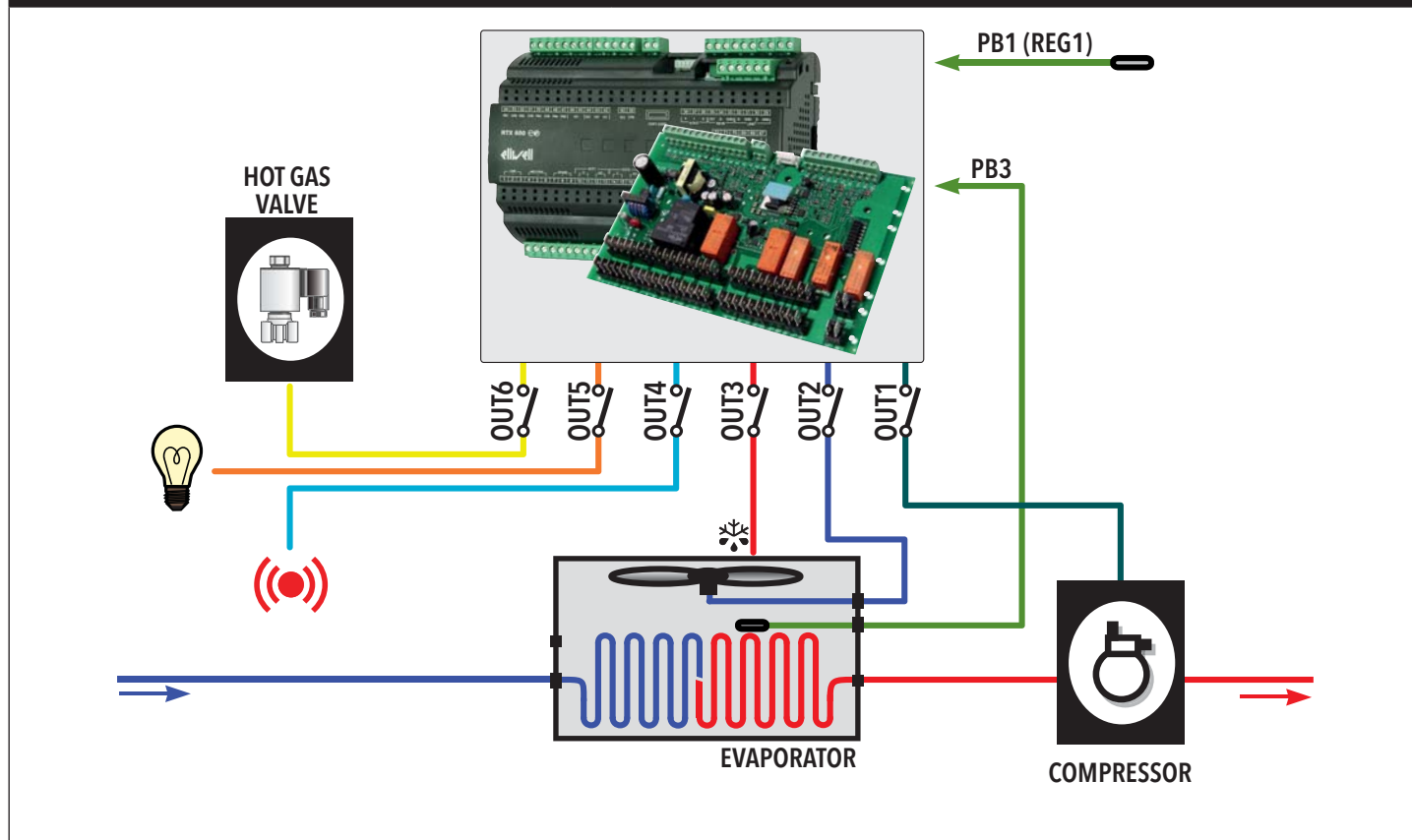



### 3.9 - APPLICATION 8

The application is configured for "VERTICAL GLASS DOOR DISPLAY CABINETS" at low temperature values, resistance defrost and frame heater with probe, recommended for the storage of frozen foods. The preset configuration features:

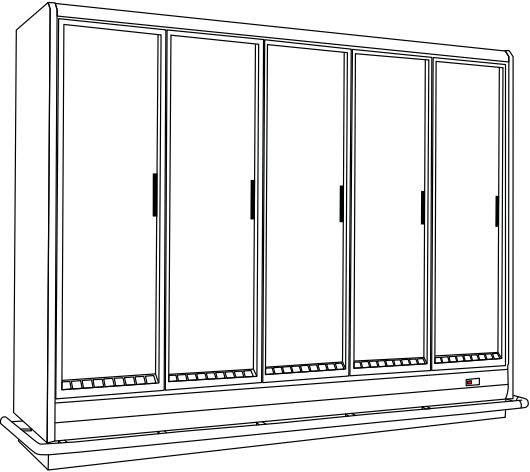
APPLICATION	APPLICATION DATA
	<p><b>Settings for Inputs, Outputs and Keys are listed below:</b></p> <p><b>Input Configuration:</b></p> <ul style="list-style-type: none"> <li>• Input PB1 = regulator sensor REG1</li> <li>• Input PB2 = not set</li> <li>• Input PB3 = evaporator sensor</li> <li>• Input PB4 = 0...10V frame heater output</li> <li>• Input PB5 = not set</li> <li>• Input DI = door switch</li> <li>• Input DI2 = not set</li> <li>• Input DI3 = not set</li> </ul> <p><b>Output Configuration:</b></p> <ul style="list-style-type: none"> <li>• OUT1 (16A relay) = compressor</li> <li>• OUT2 (16A relay) = evaporator fans</li> <li>• OUT3 (16A relay) = Defrost 1</li> <li>• OUT4 (8A relay) = alarm</li> <li>• OUT5 (8A relay) = light</li> <li>• OUT6 (8A relay) = not set</li> <li>• DAC = Frame Heater output 0...10V</li> <li>• OC = not set</li> </ul> <p><b>Key configuration:</b></p> <ul style="list-style-type: none"> <li>• UP key = manual defrost</li> <li>• DOWN key = not set</li> <li>• ESC key = stand-by</li> </ul>

#### APPLICATION DIAGRAM

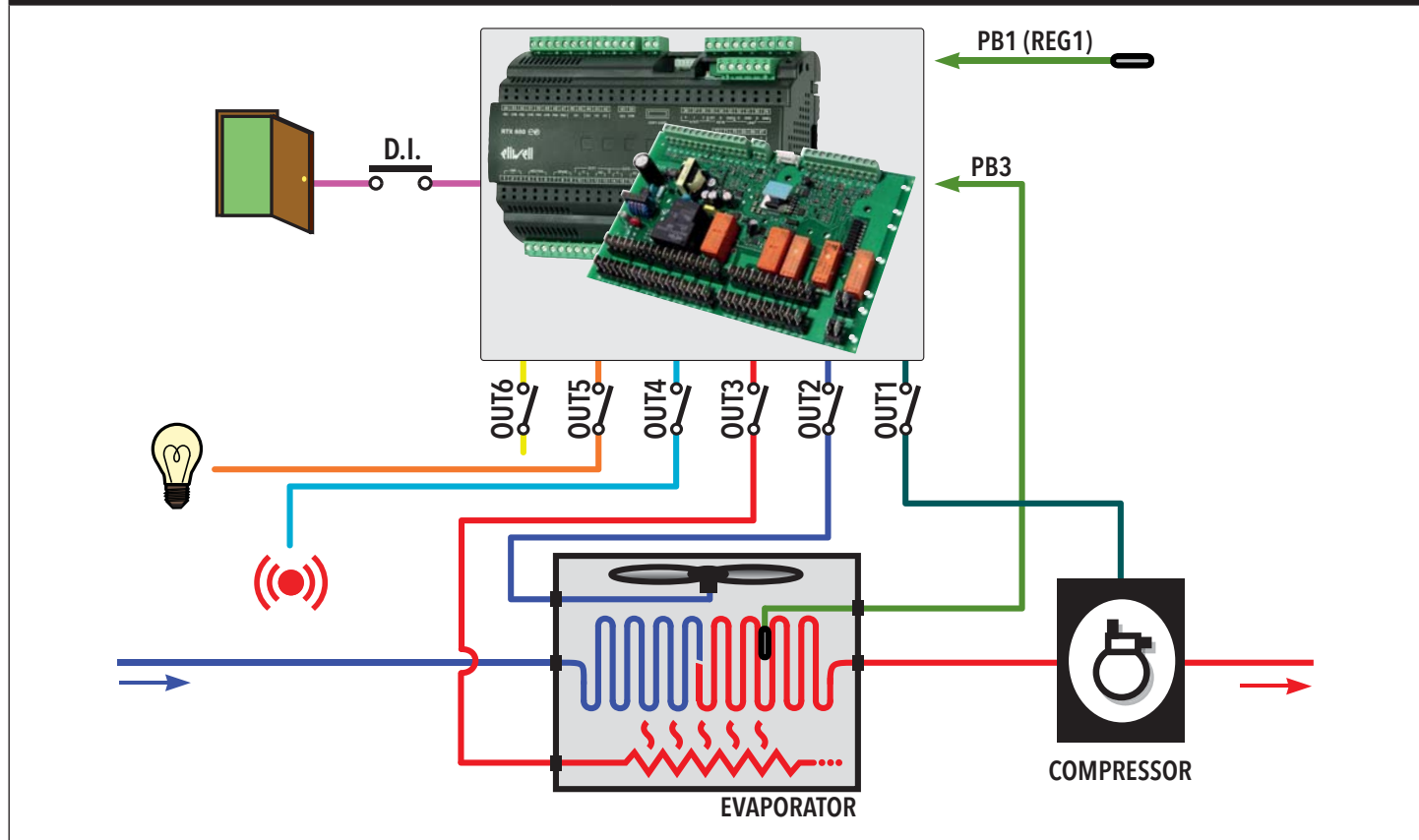

## 4 - KEYBOARD USER INTERFACE AND START-UP



### 4.1 - LED

RTX600-RTN600 family controllers will also function even if a keyboard has not been connected.

With KDEPlus or KDWPlus keyboards (which are the same and guarantee the same functions), the display will be as follows:

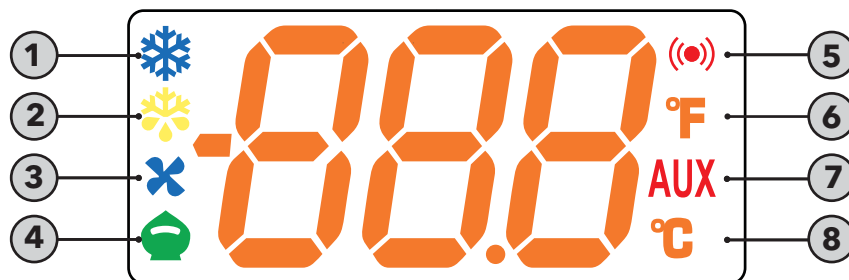

Meaning of LEDs:

No	Icon	LED	Operation	Meaning
1		<b>Compressor</b>	Permanently on	compressor on
			Blinking	Delay, protection or start-up blocked
			OFF	otherwise
2		<b>Defrost</b>	Permanently on	Defrost active
			Blinking	Activated manually or from Digital Input
			OFF	otherwise
3		<b>Fans</b>	Permanently on	Fans active
			OFF	otherwise
4		<b>Reduced SET / Economy</b>	Permanently on	Energy Saving active
			Blinking	Reduced setpoint active
			OFF	otherwise
5		<b>Alarm</b>	Permanently on	alarm active
			Blinking	Alarm acknowledged
			OFF	otherwise
6		<b>°F readout</b>	Permanently on	°F setting (dro =1)
			OFF	otherwise
7		<b>AUX</b>	Permanently on	Aux output active and/or light on
			Blinking	Deep cooling on
			OFF	otherwise
8		<b>°C readout</b>	Permanently on	°C setting (dro = 0)
			OFF	otherwise

**N.B.:** When the instrument is powered on it performs a lamp test, during which time the display and LEDs will flash for several seconds to check that they all function correctly.



## 4.2 - KDEPLUS

The KDEPlus keyboard has 4 keys, as shown in the illustration:







Each key has a different function depending on whether it is:

- Pressed and released
- Pressed for at least 5 seconds
- Pressed and held at start-up
- Pressed in combination with another key.

### KEYS

The following table summarizes the function of each key:

No	Key	Action		
		Pressed and released	Press for at least 5 secs	Start-up
1		- Scrolls through menu items - Decreases values	- Activates the <b>Manual Defrost function</b> (from outside menus).	---
2		- Scrolls through menu items - Decreases values	- Function can be configured by the user (from outside menus). (see parameter H32)	---
3		- Returns to the previous menu level - Confirms parameter value	- Activates the Stand-by function (from outside menus).	---
4		- Displays any alarms (if active) - Opens Machine Status menu - Confirms commands	- Opens the Programming Menu (User and Installer parameters)	When pressed during start-up it enables the user to select the application to be loaded.



## 4.3 - KDWPLUS

The KDWPlus keyboard has 6 keys and 5 LEDs, as shown in the illustration:

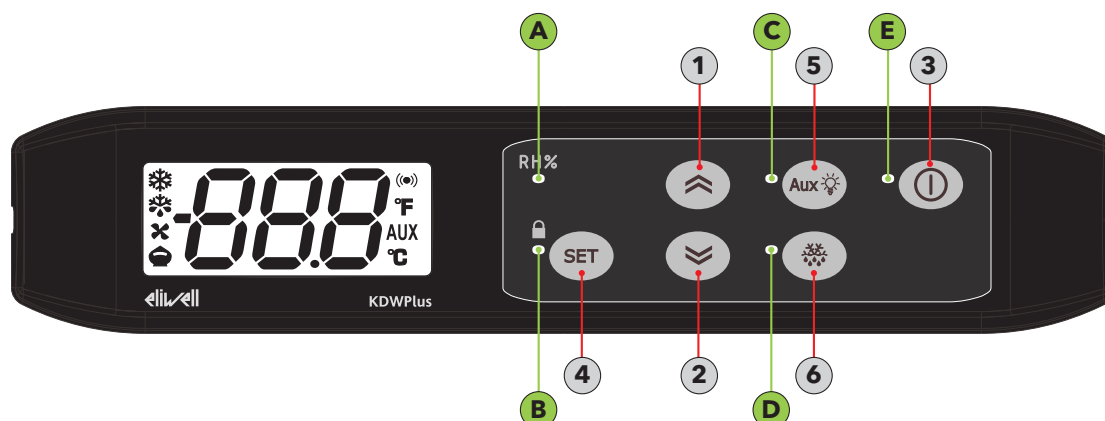

Each key has a different function depending on whether it is:

- Pressed and released
- Pressed for at least 5 seconds
- Pressed and held at start-up
- Pressed in combination with another key.

### KEYS

The following table summarizes the function of each key:

No	Key	Action		
		Pressed and released	Press for at least 5 secs	Start-up
1		- Scrolls through menu items - Increases values	- Function can be configured by the user (from outside menus). (see parameter H31)	---
2		- Scrolls through menu items - Decreases values	- Function can be configured by the user (from outside menus). (see parameter H32)	---
3		- Returns to the previous menu level - Confirms parameter value	- Activates the Stand-by function (from outside menus). (see parameter H33)	---
4		- Displays any alarms (if active) - Opens Machine Status menu - Confirms commands	- Opens the Programming Menu (User and Installer parameters)	When pressed during start-up it enables the user to select the application to be loaded.
5		- Activates the <b>Manual Defrost function</b> - Returns to the previous menu level	---	---
6		Activates the AUX output / Switches on the Light	---	---

### LED

The following table summarizes the function of each LED:

No	LED	Description
A		Forces fan on (Hxx = 15)
B		Locked keypad
C		Light relay on from key
D		Defrost ON
E		Device off





## 4.4 - CONNECTIONS WITH REMOTE TERMINAL AND REMOTE DISPLAY

Each power board can be connected to a single **KDEPlus** or **KDWPlus** keypad (user terminal) and if required to an **ECPlus** module (remote display) by means of the connector located on the keypad.

### RTX600-RTN600 + KDEPlus CONNECTION

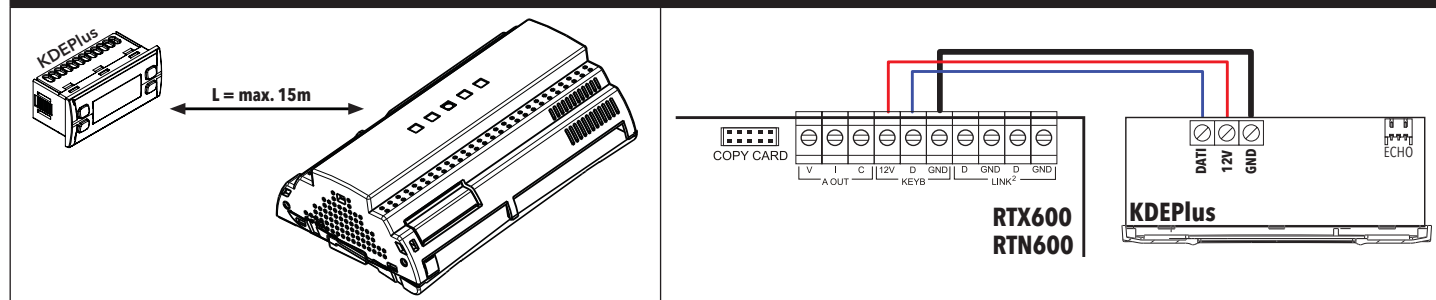

### RTX600-RTN600 + ECPlus CONNECTION

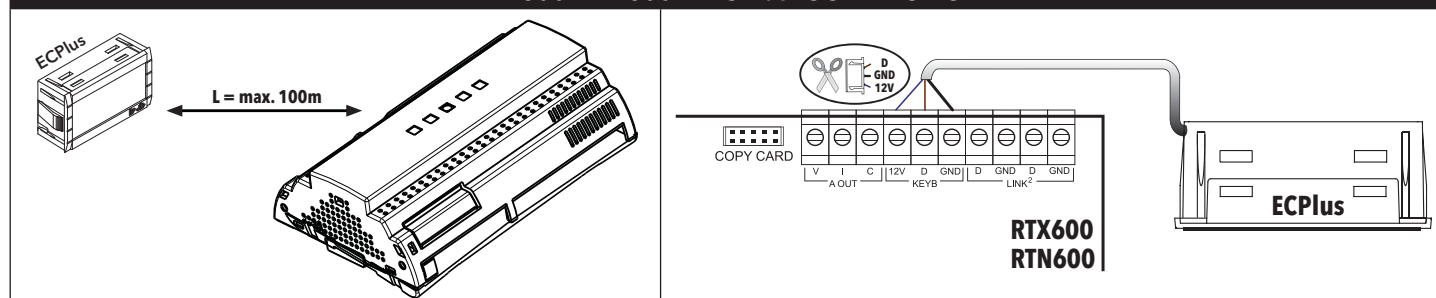

### RTX600-RTN600 + KDEPlus + ECPlus CONNECTION

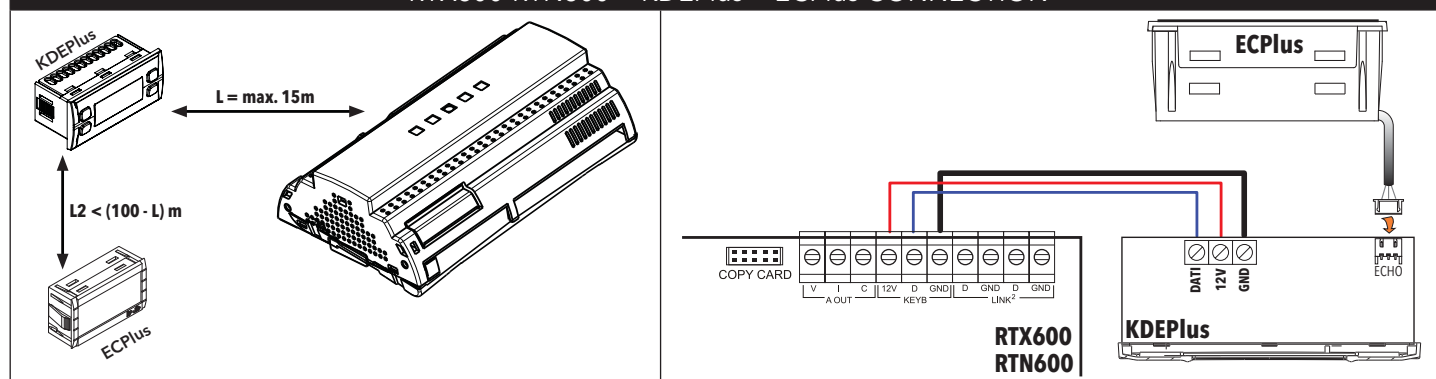

### RTX600-RTN600 + KDWPlus + ECPlus CONNECTION

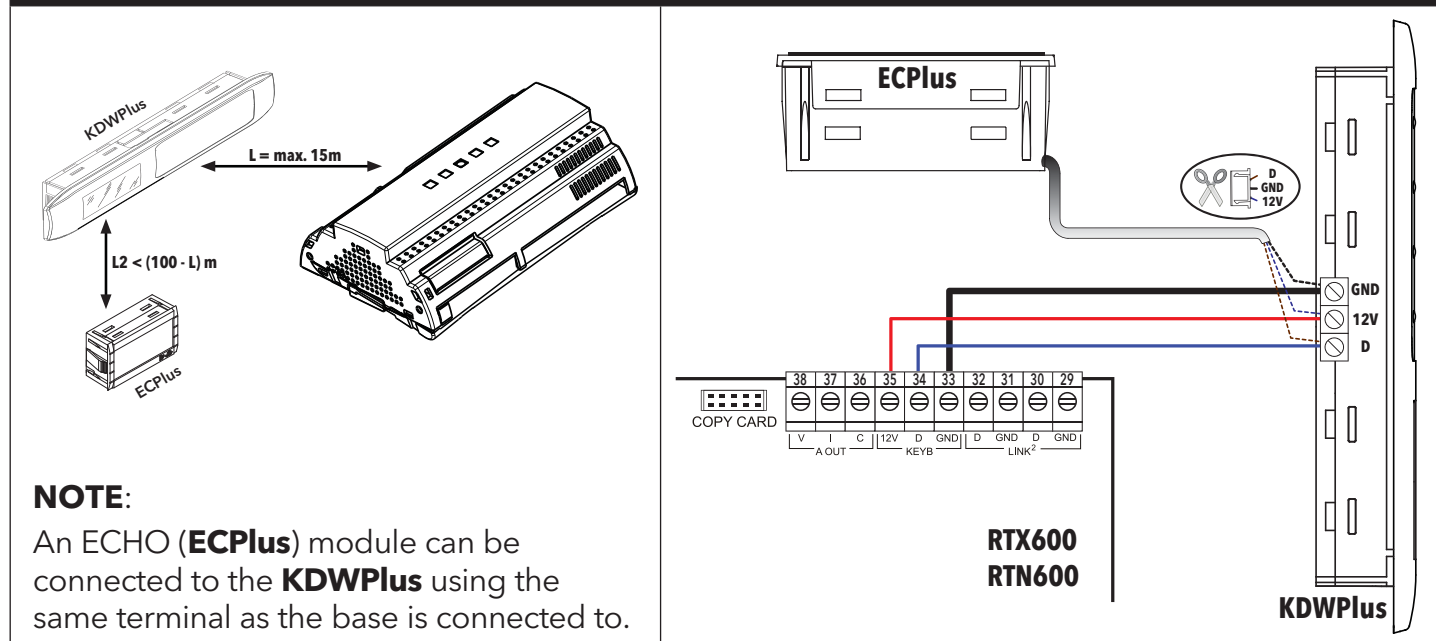

#### NOTE:

An ECHO (**ECPlus**) module can be connected to the **KDWPlus** using the same terminal as the base is connected to.



## 4.5 - PRELIMINARY SETTINGS

After making the electrical connections, simply power up the device to start operation. On the first start-up, Eliwell recommends that you:

- 1) Select the preset Application that most closely resembles your own.
- 2) Configure the main parameters listed in the USER menu to suit your requirements.
- 3) Make sure there are no active alarms (" (●) " icon off and labels E1, E2, E3, E4, E5, EL or Ei are not displayed).

### 4.5.1 - SELECTING APPLICATIONS

The procedure for loading one of the default applications is:

- On switching the controller on, press and hold the **set** key: the label "AP1" will appear.
- Scroll through the various applications (AP1... AP8) using the **▲** and **▼** keys.
- Select the desired application using the **set** key ("AP3" in the example) or cancel the procedure by pressing the **ⓘ** key; alternatively wait for the timeout.
- If the operation is successful, the display will show "y", if not it will show "n".
- After a few seconds the instrument will return to the main display.

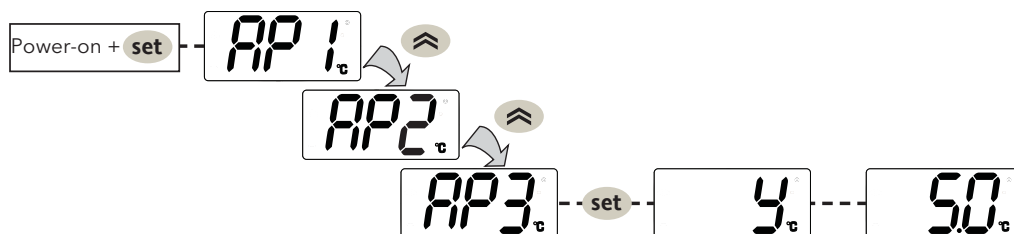

### 4.5.2 - RESET PROCEDURE

**RTX600** and **RTN600** can be **RESET** and the default factory settings restored in a simple and user-friendly way. This is done by simply reloading one of the basic applications (see "Loading default applications").

You may need to **RESET** the instrument in circumstances in which the normal operation of the instrument is compromised or if you decide to restore the instrument to its default configuration (e.g. Application 1 values).



**IMPORTANT!:** This operation resets the instrument to its initial state, returning all the parameters to their default values. This means that all changes made to operating parameters will be lost.

### 4.5.3 - PASSWORDS

**Password "PA1"**: grants access to User parameters. By default the password is disabled (**PS1=0**).

To enable it (**PS1≠0**): press and hold **set** for more than 5 seconds, scroll through the parameters using **▲** and **▼** until you see label **PS1**; press **set** to display the value, modify it using **▲** and **▼**, then save it by pressing **set** or **ⓘ**. If enabled, it will be needed to access the User parameters.

**Password "PA2"**: grants access to Installer parameters. By default the password is enabled (**PS2=10**).

To modify it (**PS2≠10**): press and hold **set** for more than 5 seconds, scroll through the parameters using **▲** and **▼** until you see label **PA2**; press **set**, set the value "15" using **▲** and **▼**, then confirm using **set**. Scroll through the folders until you see label diS then press **set** to enter. Scroll through the parameters with **▲** and **▼** until you see label **PS2**, press **set** to display the value, modify it using **▲** and **▼**, then save it by pressing **set** or **ⓘ**.

The visibility of "**PA2**" is:

- 1) **PA1 and PA2 ≠ 0:** Press and hold **set** for more than 5 seconds to display "**PA1**" and "**PA2**". You can then decide whether to access the "**User**" parameters (**PA1**) or "**Installer**" parameters (**PA2**).
- 2) **Otherwise:** Password "**PA2**" is amongst the level 1 parameters. If enabled, it will be needed to access "Installer" parameters; to enter it, proceed as instructed for password **PA1**.

If the entered value is incorrect, label **PA1/PA2** will be displayed once again and the procedure must be repeated.



#### 4.5.4 - SETPOINT: SETTING AND EDIT LOCK

To display the Setpoint value, press the **set** key to enter the "Machine Status" menu, then press the **set** key again when the "SEt" label is displayed.

The Setpoint value appears on the display. To change the Setpoint value, press the **⏮** and **⏭** keys within 15 seconds. Press **set** to confirm the modification.

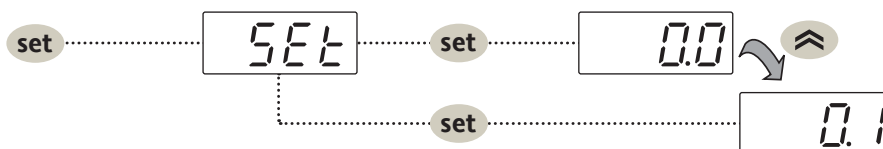

It is possible to disable the keypad on this device.

The keypad can be locked by programming the "LOC" parameter appropriately.

With the keypad locked, you can still access the "Machine Status" menu by pressing **set** to display the Setpoint, but you cannot edit it. To disable the keypad lock, repeat the locking procedure.

#### 4.5.5 - DISPLAY PROBES VALUE

To display the value read by probes connected to the device, press the **set** key and enter the "Machine Status" menu, then press the key again when one of the probe-related labels "Pb1 .... Pb5" press the **set** key again. The value measured by the associated probe will appear on the display.

**NOTE:** The displayed value is read-only and cannot be modified.

#### 4.5.6 - KEY-ACTIVATED FUNCTIONS

All models have the **UP** key set to enable the "Manual Defrost" function.

The DOWN and ESC keys can also be set to activate any other function required by the user.

The parameters for configuring the two keys are:

- **H11** = DOWN key configuration
- **H33** = ESC key configuration

The values that can be set apply to both keys and the functions that can be activated are:

H32/H33 value	Function to enable
0	disabled
1	defrost
2	reduced set
3	Light
4	Energy saving
5	AUX
6	Stand-by
7	Deep cooling cycle
8	Start/end defrost



## 4.5.7 - "MACHINE STATUS" MENU

Access the "Machine Status" menu by pressing and releasing the **set** key. By pressing the **UP** and **DOWN** keys you can scroll through all menu folders.

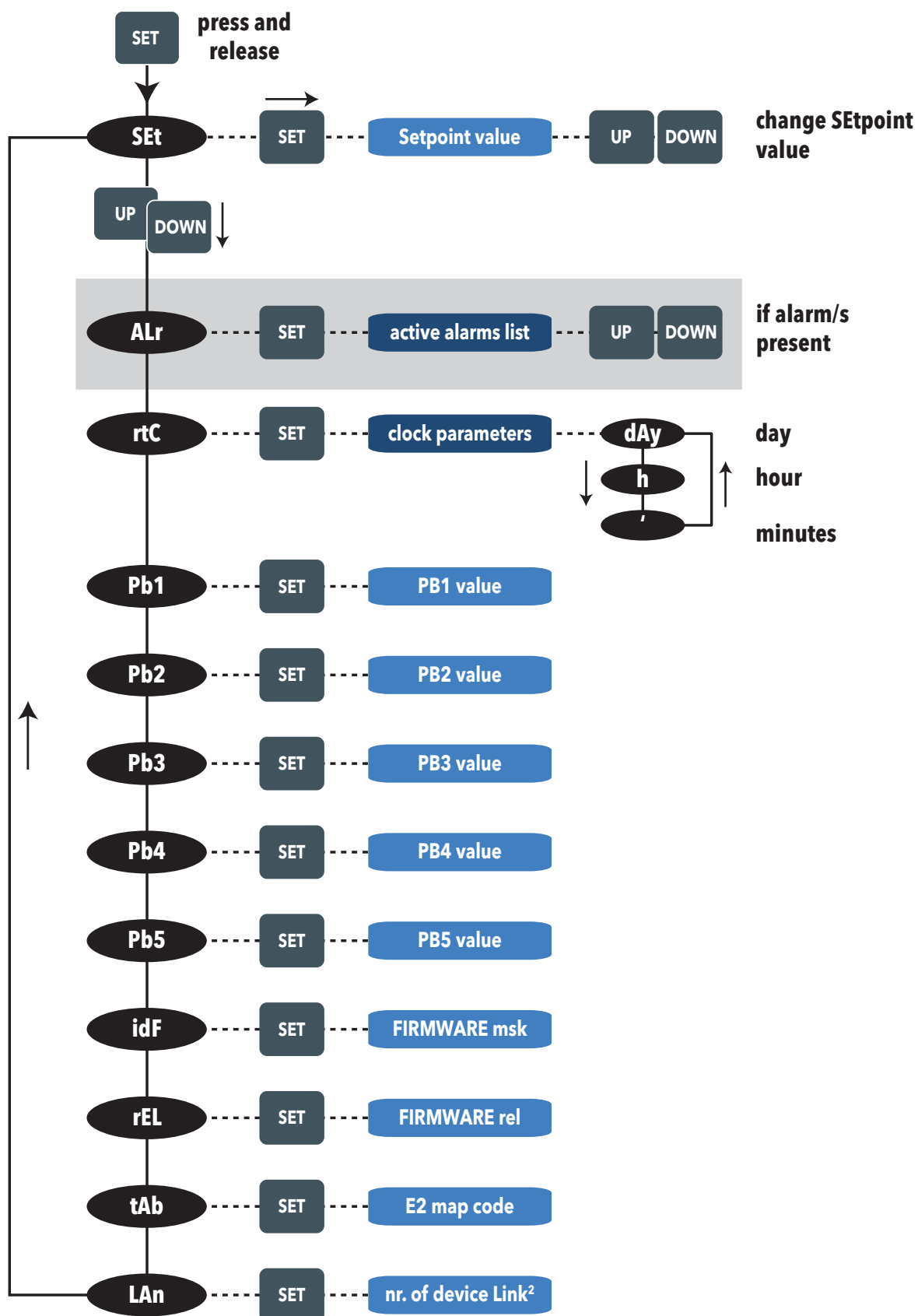



## 4.5.8 - PROGRAMMING MENU

To access the "Programming" menu, press and hold the **set** key for more than 5 seconds. If enabled, the instrument will request an access PASSWORD, either **PA1** for "User" parameters or **PA2** for "Installer" parameters (see "PASSWORD" section).

**"User" Parameters:** When accessed, the display will show the first parameter (e.g. "rE"). Press **UP** and **DOWN** to scroll through all of the parameters in the current level. Select the desired parameter by pressing **set**. Press **UP** and **DOWN** to change it and **set** to save the changes.

**"Installer" parameters:** When accessed the display will show the first folder (e.g. "CP"). Press **UP** and **DOWN** to scroll through all of the folders in the current level. Select the desired folder using **set**. Press **UP** and **DOWN** to scroll through the parameters in the current folder and select the parameter using **set**. Press **UP** and **DOWN** to change it and **set** to save the changes.



**N.B.:** It is strongly recommended that you switch the device off and on again each time the parameter configuration is changed, in order to prevent malfunctioning of the configuration and/or ongoing timings.

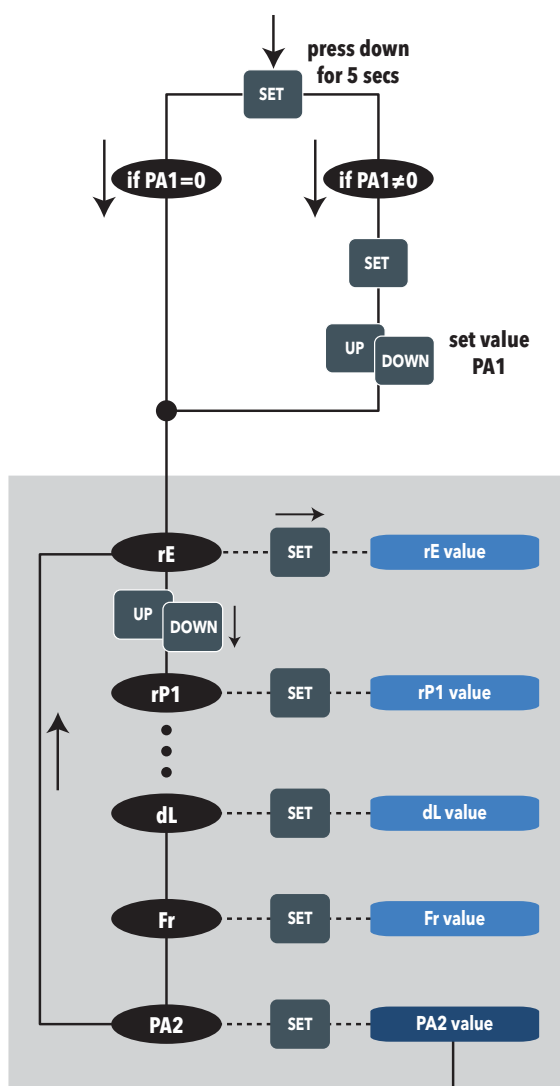

level 1

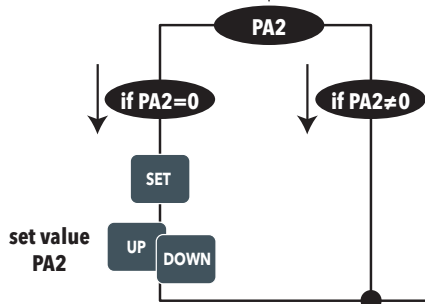

### NOTE: For folders and parameters:

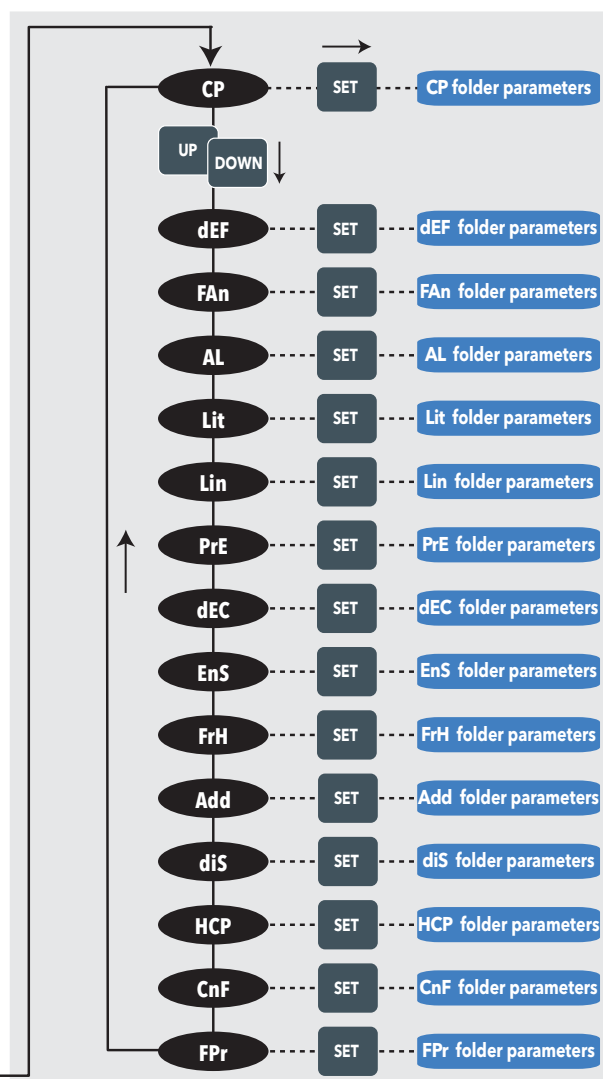
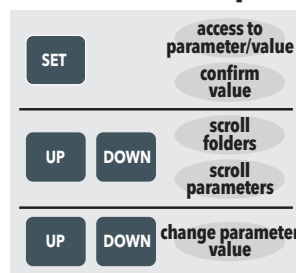

level 2



This section describes the various functions of the devices.



**IMPORTANT:** the functions may not be available in certain models.

## 5.1 - SETTINGS

### 5.1.1 - PROBE SETTING AND CALIBRATION

**RTX600-RTN600** have 5 configurable NTC/PTC/PT1000/D.I. inputs (PB1 ... PB5).

The temperature probes (PB1 ... must all be of the same type and must be configured using parameter **H00**.

Parameter **H00** is located in the "Installer" menu in folder "**CnF**" and must be set as follows:

- **H00** = Ptc if using PTC probes.
- **H00** = ntc if using NTC probes (Default).
- **H00** = Pt1 if using PT1000 probes.

After installation, the values read by the probes can be corrected/calibrated using the following parameters:

- **CA1:** probe 1 offset. Positive or negative value to be added to the value read by Pb1 (Range: **-30.0 ... +30.0**)
- **CA2:** probe 2 offset. Positive or negative value to be added to the value read by Pb2 (Range: **-30.0 ... +30.0**)
- **CA3:** probe 3 offset. Positive or negative value to be added to the value read by Pb3 (Range: **-30.0 ... +30.0**)
- **CA4:** probe 4 offset. Positive or negative value to be added to the value read by Pb4 (Range: **-30.0 ... +30.0**)
- **CA5:** probe 5 offset. Positive or negative value to be added to the value read by Pb5 (Range: **-30.0 ... +30.0**)

### 5.1.2 - DISPLAY SETTINGS

Folder "**dis**", at the **User** or **Installer** level, contains the parameters used to set the temperature readout, decimal point usage, unit of measurement and display during defrost.

- **ndt:** (**User**) enables/disables decimal point display (with resolution of one-tenth of a degree; e.g.: 10.0°C)  
Display with decimal point is only possible within the range of values from -99.9°C to +99.9°C
  - ndt = yes → displays read values with decimal point (default).
  - ndt = no → displays read values without decimal point.



**NOTE:**

enabling/disabling the decimal point only affects the on-screen display of values. The controller will continue to perform calculations with decimal point.

- **ddl:** (**User**) sets the type of display during and up to the end of defrost.
  - ddl = 0 → displays the value of Pb1 (default).
  - ddl = 1 → continues to display the value read by the probe at the start of defrosting.
  - ddl = 2 → displays fixed label "**DEF**".
- **dro:** (**Inst**) sets temperature display to °C or °F.
  - dro = 0 → display in °C (default).
  - dro = 1 → display in °F.



**IMPORTANT!**

switching between °C and °F DOES NOT modify the temperature parameter values, etc. (e.g. set=10°C becomes 10°F). This means that the maximum and minimum limits of parameters as an absolute value are the same for both units of measurement and the ranges are therefore different from each other.

- **ddd:** (**User**) sets the value to be displayed.  
All other display and adjustment modes are the same.
  - ddd = SP1 → disabled
  - ddd = Pb1 → displays values read by Pb1
  - ddd = Pb2 → displays the values read by Pb2
  - ddd = Pb3 → displays the values read by Pb3
  - ddd = Pb4 → displays the values read by Pb4
  - ddd = Pb5 → displays the values read by Pb5
  - ddd = Pbi → displays the values read by the virtual probe
  - ddd = LP → displays the values read by the LINK<sup>2</sup> network probe.



## 5.2 - FUNCTIONS

### 5.2.1 - UPLOAD, DOWNLOAD, FORMAT

#### Description

The Unicard/Multi Function Key must be connected to the serial port (TTL) and allows the rapid programming of instrument parameters.



**DOWNLOAD** from reset only operating mode: at power-on, if the Unicard/Multi Function Key is inserted in the device, the controller automatically downloads data.







After connecting the Unicard/Multi Function Key with the device switched off and on completion of the lamp test, one of the following labels will be displayed:

- **dLY** if the operation was successful
- **dLn** if the operation was not successful

After about 5 seconds, the display will display the probe or setpoint value, depending on the default settings.



**IMPORTANT !** once download has been completed successfully, the controller will start to work with the new map loaded.

Operating mode: access "Installer" parameters by entering the password "**PA2**" if enabled (PA2≠0), scroll through the folders using  and  until folder "**FPr**" appears. Select it using , scroll through the parameters using  and  then select one of the functions by pressing .

- **UL** (Upload): This function uploads the programming parameters from the instrument to the card. If the operation is successful, the display will show "**y**", otherwise it will show "**n**".
- **Fr** (Format): This command is used to format the copy card (which is necessary when using the card for the first time). Important: the **Fr** parameter deletes all data present and this operation cannot be reversed.
- **Download**: Connect the Unicard/Multi Function Key with the instrument switched off. At power-on, data will automatically start downloading from the Unicard/Multi Function Key to the controller. At the end of the lamp test, the display will show "**dLY**" if the operation was successful and "**dLn**" if not.



**IMPORTANT !** before uploading or downloading a map, make sure that communication between the controller and supervisor (PC with Televis system, TelevisCompact, etc.) has been terminated. In other words, remember to disconnect the RS485 from the controller or stop data acquisition by the Supervisor.

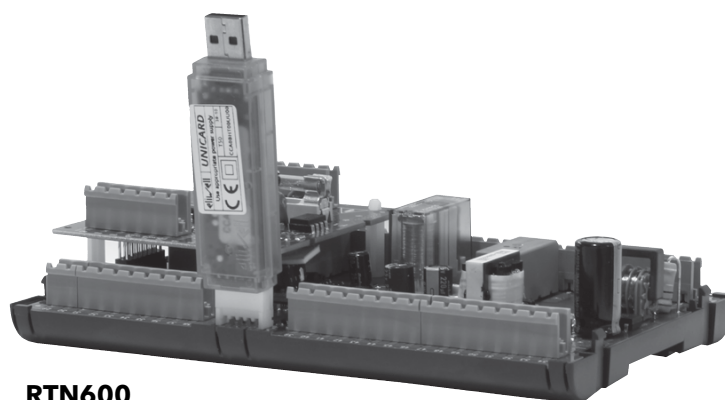

#### User parameters

The parameters that control this function are:

Label	Description
UL	Transfer of programming parameters from controller to Unicard/Multi Function Key.
Fr	Format Unicard/Multi Function Key. Erases all data contained in the Copy Card.







## 5.2.2 - FIRMWARE BOOT LOADER

The instrument is equipped with a Boot Loader, so it is possible to update the Firmware directly on the field. Updating may be carried out using UNICARD or MULTI FUNCTION KEY (MFK).

Updating procedure:

- Connect the UNICARD/MFK equipped with the application;
- Power the instrument if it is off, otherwise switch it off and on again



**NOTE:** the UNICARD/MFK can be connected even with the instrument powered.

- Wait until the led of the UNICARD/MFK is blinking (operation in progress);
- The operation will be concluded when the Led of the UNICARD/MFK is:
  - **ON:** operation concluded correctly;
  - **OFF:** operation not performed (application not compatible ...)



**ATTENTION:** the led display is guaranteed only for UNICARDS produced from week 18-12 onward.



In order to download the Firmware application on the UNICARD (in CLONE mode as used for parameters maps) you must use the Device Manager (version 05.00.06 or later), which you can download from the Eliwell site after having registered at level 2.



**NOTE:** with this version of the Device Manager the UNICARD can be connected DIRECTLY without using the DMI.

## 5.2.3 - KEYBOARD SHARED ON LINK<sup>2</sup>

From each device of a Link<sup>2</sup> network it is possible, using the local keyboard, to navigate in any one of the other devices connected in the Link<sup>2</sup>.

This menu is activated, from the default menu, by simultaneously holding down the  and  keys for 5 seconds. When remote display is active, the °C and °F icons blink.

Depending on the protocol used, you will be asked to type in the following values:

- Televis Protocol: **FAA** and **dEA**
- Modbus Protocol: **Adr**

To return to the default menu:

- Hold down the  and  keys for 5 seconds;
- By time-out, 60 seconds after a key was last pressed.

During "remote control of the display", the local keyboard (of the device of which the display has been remote controlled) is blocked. It is released 3 seconds after the release of the viewing of the display.

If the connection is lost during "remote control" viewing, the display will show:

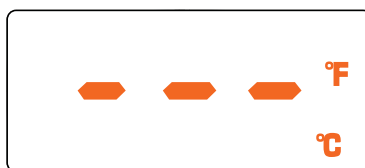



## 5.3 - REGULATORS

### 5.3.1 - LINK<sup>2</sup> NETWORK

A local network (**LINK<sup>2</sup>**) can comprise up to 8 **RTX600/RTN600** devices and allows only one of the devices to be connected to the Televis/Modbus supervision network.



**IMPORTANT:** Within each local network, the addresses of the individual devices with parameters **dEA** and **FAA**, must be preconfigured, being careful to make sure every pair is unique (they don't have to be sequential).  
Addresses **dEA** and **FAA** apply to Televis and the LINK<sup>2</sup> network.



**N.B.** we recommend assigning the same **FAA** value to all devices in a sub-network so they can be easily identified.

See the example connection LINK<sup>2</sup> + Monitoring network below:

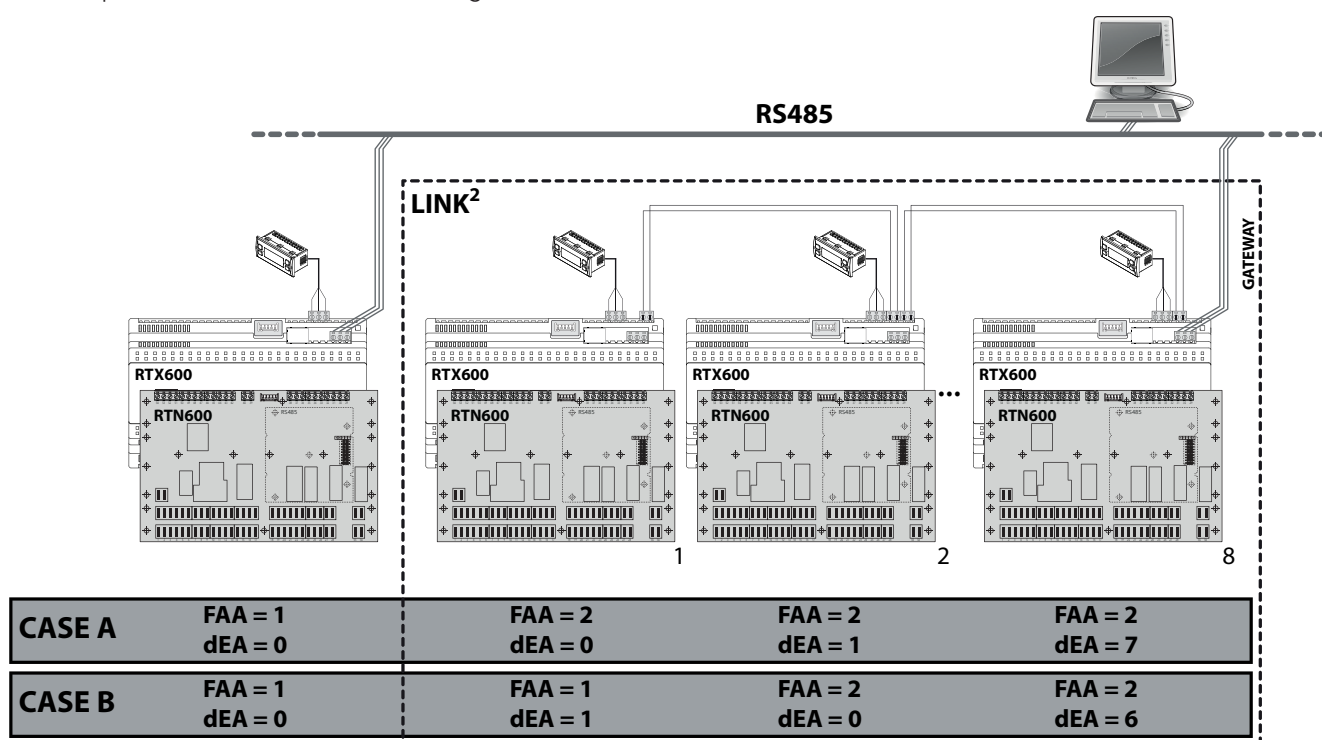

#### 5.3.1.1 - Supervision Gateway

Cabling for supervision can be simplified via the LINK<sup>2</sup> network.  
More specifically, the **RS485 supervision line** can be connected to any of the LINK<sup>2</sup>PCBs.

The latter will automatically "sort" communication with other PCBs.

The **RS485** network does not need any specific configuration for addresses as it uses those set for network supervision, such as:

- **Micronet:** using parameters **FAA** and **DEA**
- **Modbus:** using parameter **Adr.**



### 5.3.1.2 - Shared temperature probe

One of the 5 temperature probes (ST1...ST5) or the virtual probe can be shared via the LINK<sup>2</sup> network.

 **EXAMPLE 1:** A typical example is the sharing of the regulation probe.

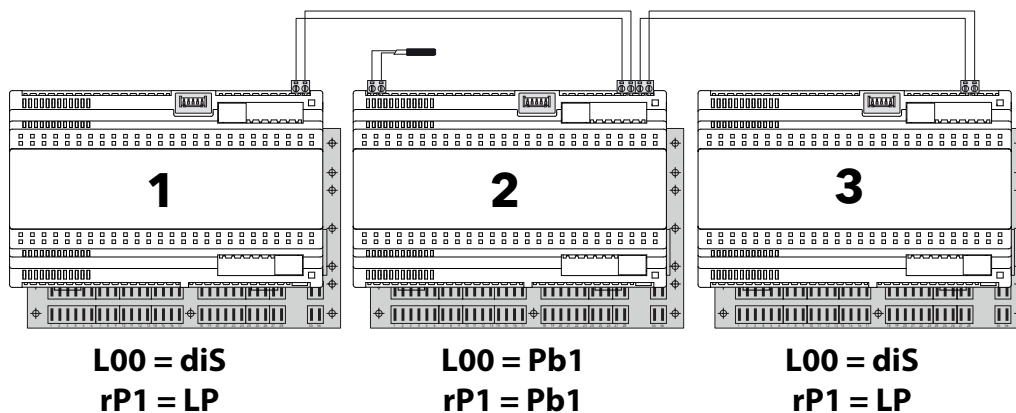

 **EXAMPLE 2:** Another possible example: in ducted counters where each section is fitted with its own regulation probe, if the regulation probe for a given section breaks, this section can be regulated using the value read for one of the adjacent sections. This operation can be carried out via remote:

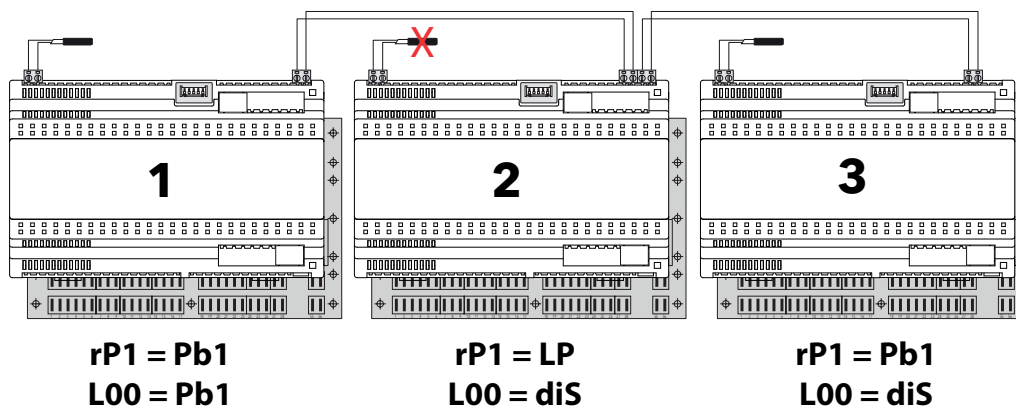
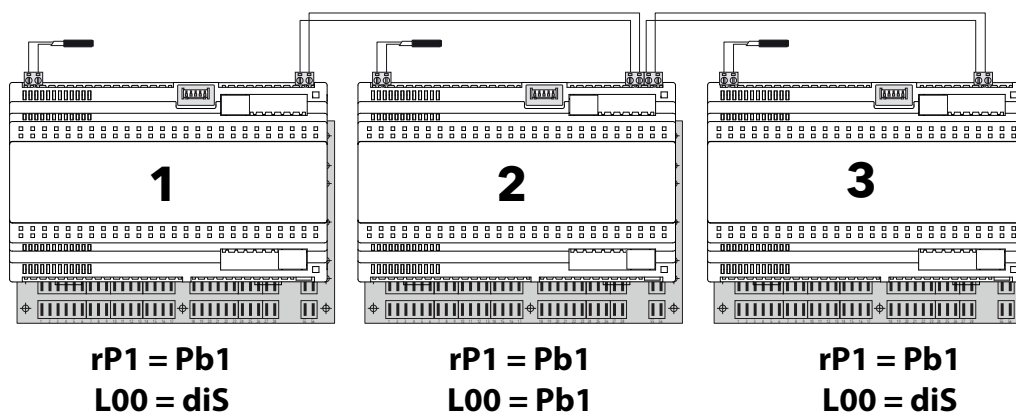

**N.B.:** Sharing the temperature probe applies not only to regulation, but also to other regulators (evaporator fans, heaters...).



### 5.3.1.3 - Defrost

Defrosting of various devices in the network can be coordinated via the LINK<sup>2</sup> network.

Coordination can be enabled via parameter **L03 = yES** in the device that will be coordinating the defrost. This parameter can also be used to indicate if, on termination of defrost, the device should wait for all devices to finish before reactivating regulation.

Nevertheless, there is a time-out in this mode (parameter L10) that forces regulation to reactivate if, during this time, the coordinating device has not reactivated regulation (e.g. the LINK<sup>2</sup> network was interrupted during defrost.)



**EXAMPLE 1:** An explanation of how to configure a current defrost is provided below, while resources are blocked. The coordinating device is device no.1. Value **x** for **L10** represents the number of minutes delay set whereas dE1/dE2 the defrost time-out set by the coordinating device.

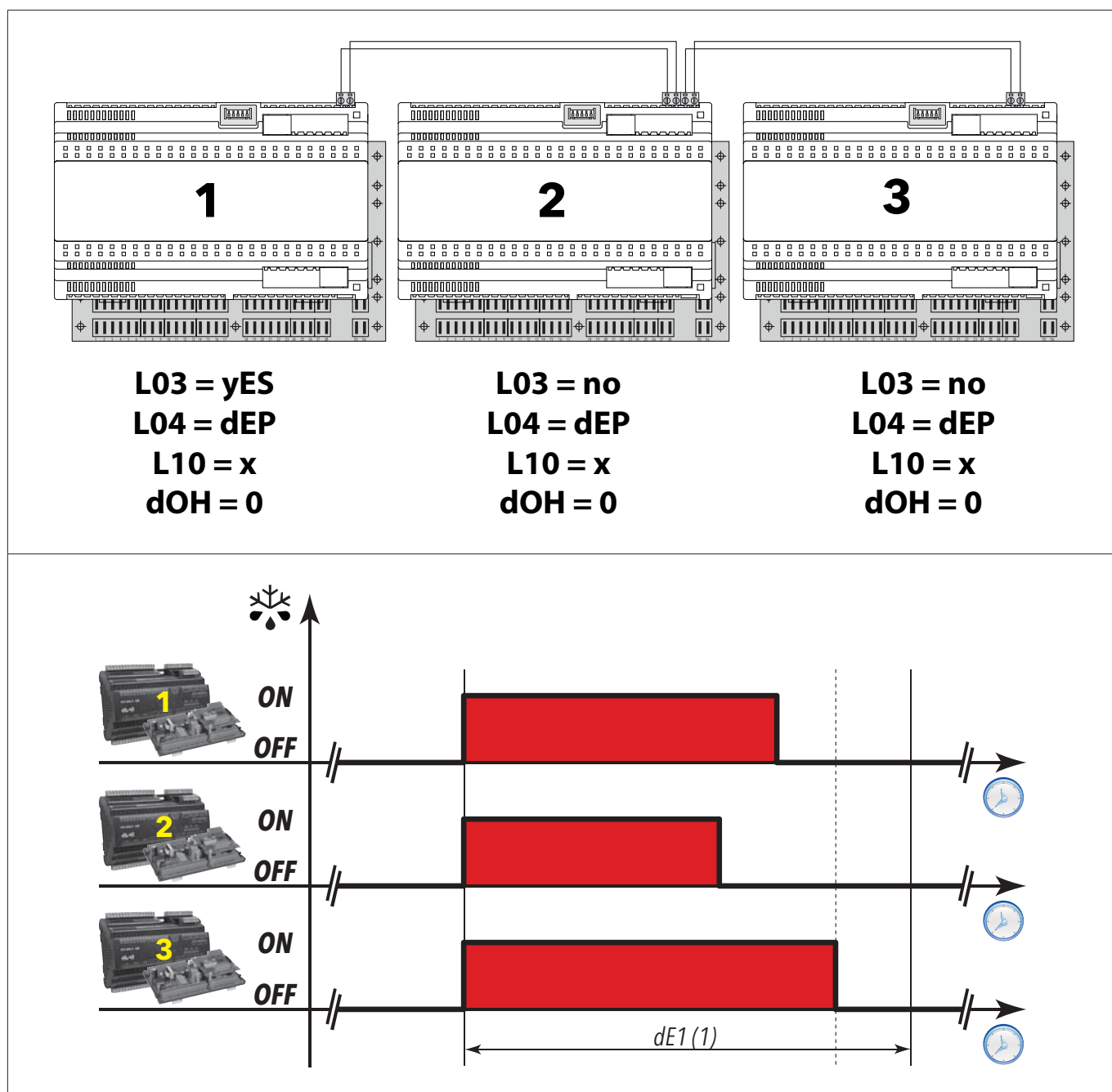

**N.B.:** When parameter **L04 = dEP**, it is suggested that you disable all the active defrosts. In this situation parameter **L10** is used.



**EXAMPLE 2:** If you want to run a sequential defrost, set parameter **dOH** to activate defrosts sequentially (in the following example, a 30-minute end of defrost time-out is used).

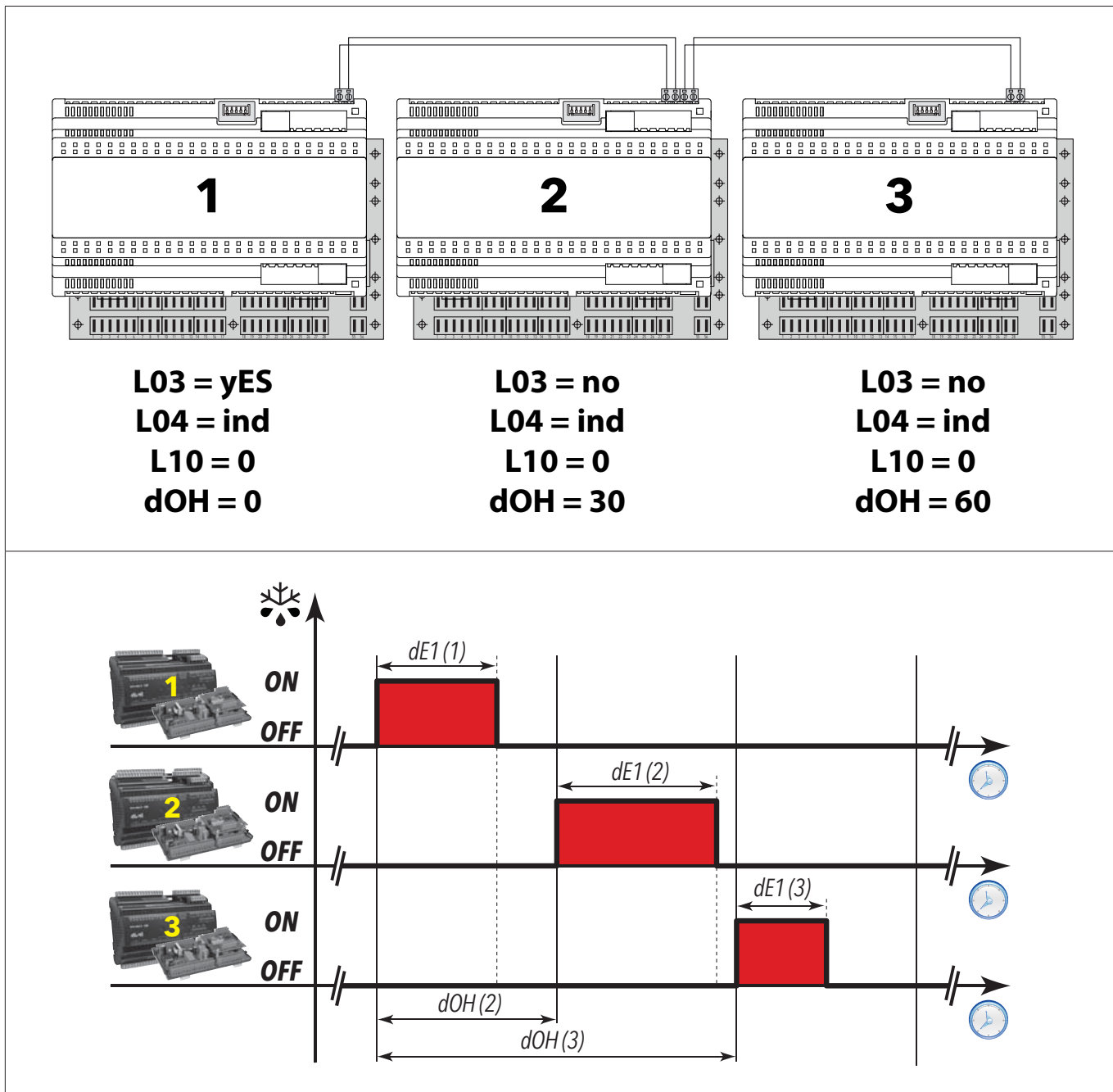

**N.B.:** In this situation, parameter **L10** is not used even if its value is **L10 > 0**.



The PCBs can implement a safety mechanism when communication between the LINK<sup>2</sup> network and the device coordinating defrost fails. To achieve this, the local defrost mode should be set to device hours, i.e. setting the value of parameter upper **dit** to the maximum time interval between two consecutive defrosts; this can then be sent to the coordinating device.

Every time the device receives a defrost request from the coordinating device, it resets timer **dit**. If the PCB no longer receives the defrost command, after a time equal to **dit**, a defrost will be activated automatically and timer **dit** will be cleared and restarted from 0.

In the example below, the **Master** is the device that coordinates defrosts and the **Slave** is any of the other devices in the network. **Box "A"** specifies the exact time at which communication between the **slave** and the **master** stopped.

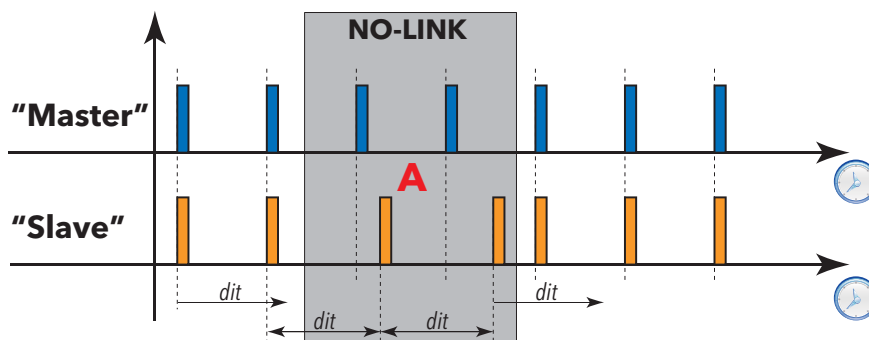

- N.B.:** 1) To operate correctly, set **dit** > maximum interval between 2 consecutive defrosts of the device configured as master for the defrost.  
 2) In the case of **dit = 0**, when there is a request from the device configured as master the slaves will defrost, but if the network communication stops the defrost will not be done.

### 5.3.1.4 - Shared display

To make sure that all keypads in the ducted counter show the same value, the display of a given PCB can be shared via the LINK<sup>2</sup> network.

**EXAMPLE:** In the following example, all PCBs will show the value of PCB no. 2. PCB's 1 and 3 will show the value of the probe mounted on PCB 2, which was selected via parameter **ddd**.

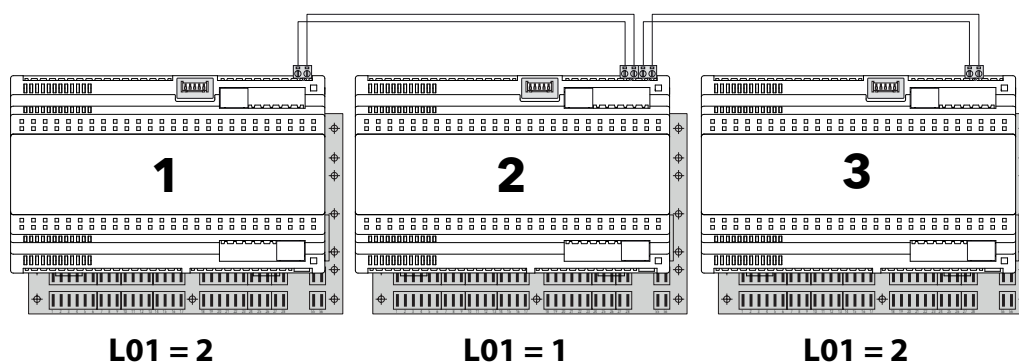

- N.B.:** 1) If PCB 2 (Master) has an activate alarm showing on the display (e.g. probe alarm), this is not shared with boards 1 and 3.  
 2) If PCB 2 shares the value of a probe in error, the other boards will show the reading set in local parameter **ddd**.  
 3) If board 1 and/or 3 have any additional alarms (e.g. local probe alarms), these will be displayed (locally).  
 4) If PCB 1 and/or 3 do not receive the distributed display (LINK<sup>2</sup> signal interrupted), they will show the reading selected in local parameter **ddd**.



### 5.3.1.5 - Shared setpoint value

The regulation setpoint SP1 can be shared with all PCBs via the LINK<sup>2</sup> network.

If the setpoint is modified for any one of the PCBs in the LINK<sup>2</sup> network, the setpoint will be automatically updated in all other PCBs in the LINK<sup>2</sup> network.

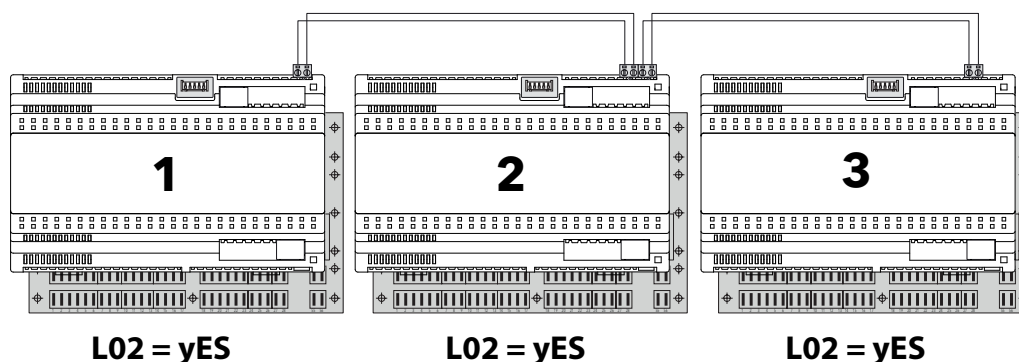

**N.B.:** When parameter **L02 = yES**, if the setpoint value is changed in any one of the devices, the same value will be set in all the other network devices.  
If one of the devices is disconnected from the network or if the communication stops after a change of setpoint value, it will continue to use the new set value.

### 5.3.1.6 - Shared commands

The following commands can be shared via the LINK<sup>2</sup> network:

- Stand-By
- Lights
- AUX
- Energy Saving

(See parameters L00 ... L10 in folder **Lin**)

### User parameters

The parameters that manage this regulator are:

Label	Description
rP1	Sets which regulation 1 probe to use.
dit	Interval between the start of two consecutive defrost cycles. 0 = function disabled.
dOH	Time delay to activate defrost cycle after request.
L00	Selects which probe to share.
L01	Shares the value displayed with the LAN network.
L02	Sends the setpoint value to the LAN network after it has been modified.
L03	Enables the defrost request to be sent to the LAN network.
L04	End defrost mode. ind = independent; dEP = dependent.
L05	Enables the Stand-by command to be synchronized. yes = yes; no = no.
L06	Enables the light command to be synchronized. yes = yes; no = no.
L07	Enables the Energy Saving command to be synchronized. yes = yes; no = no.
L08	Enables the AUX command to be synchronized. yes = yes; no = no.
L10	Sets the time delay to be set after the end of dependent defrosts.
dEA	Device address: indicates the device address to the management protocol.
FAA	Family address: indicates the device family to the management protocol.
Adr	Modbus protocol controller address.
ddd	Selects type of value to display.



## 5.3.2 - REGULATION

RTX600-RTN600 offers a selection of different regulation modes:

- Single thermostat.
- Double thermostat (series).
- Double thermostat (parallel).
- Two power step regulation.



**N.B.:** when working with a "single thermostat", you can have an auxiliary regulator for user-customized applications (e.g. light sensor management, etc.).

### 5.3.2.1 - Standard regulation mode

The standard regulator is activated by parameter **rE = 0** or **rE = 4** (in the latter case, the auxiliary regulator is also active). This regulator can work in both hot and cold (parameter **HC1**).

The regulation differential can be managed as a relative or absolute value for standard regulator **rE = 0** only:

#### RELATIVE DIFFERENTIAL (current ID):

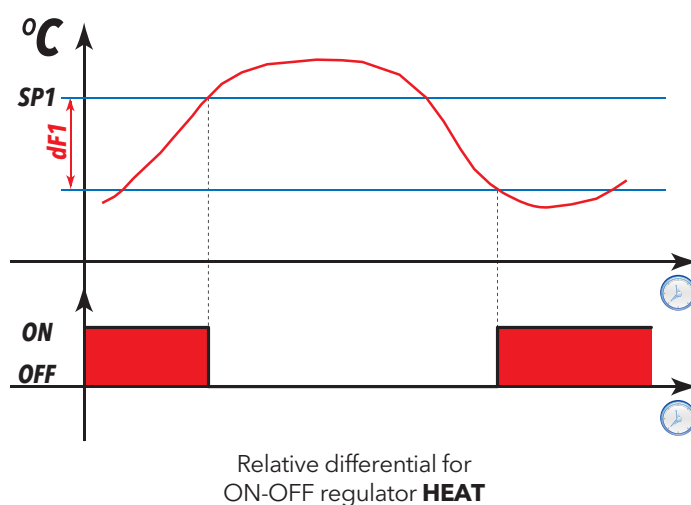
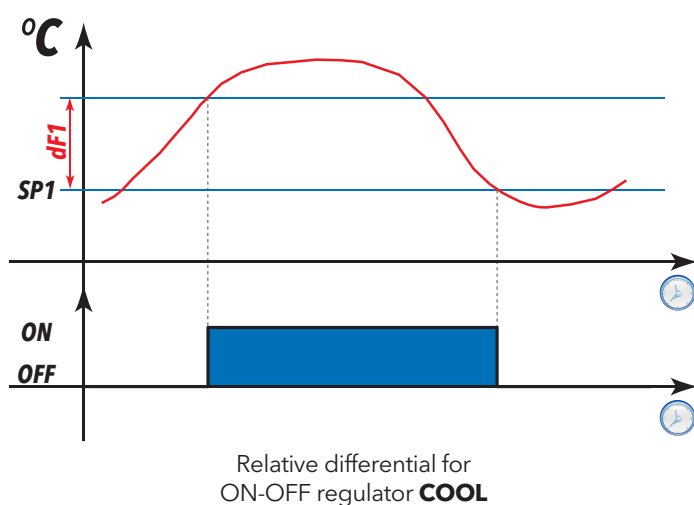

#### ABSOLUTE DIFFERENTIAL:

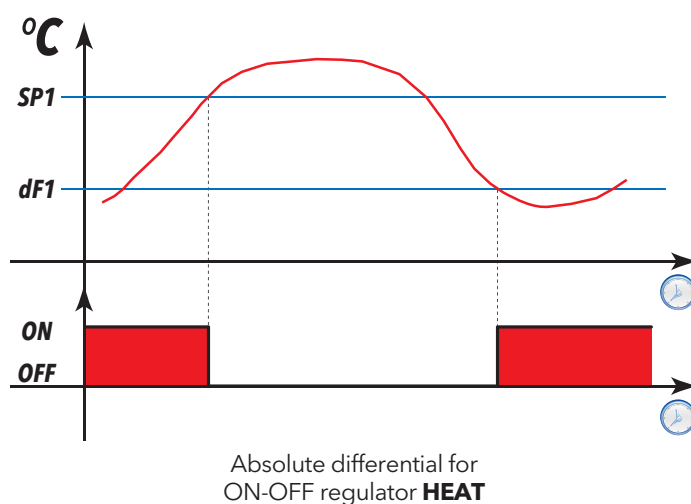
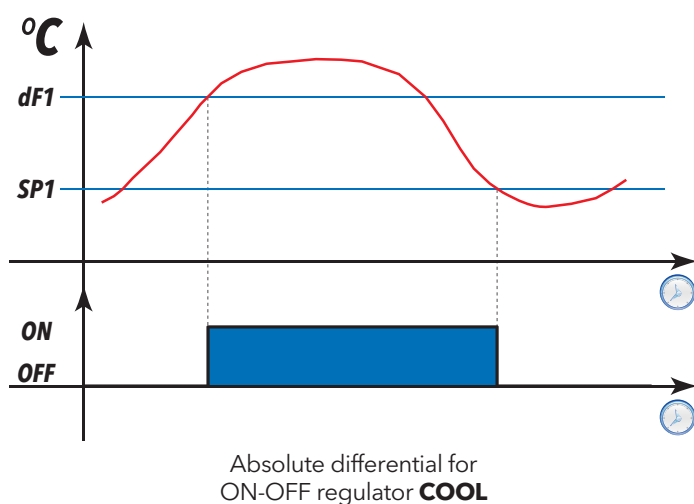





### 5.3.2.2 - Double "series" thermostat

This regulator activates cold/hot only if both thermostats have been requested, and disables it when at least one of the two thermostats has been satisfied. If one or both of the thermostats has a probe error, the regulation will use the probe error parameters. In the diagram below, **1\_T1** is the probe set as thermostat 1, and **1\_T2** is the probe set as thermostat 2.

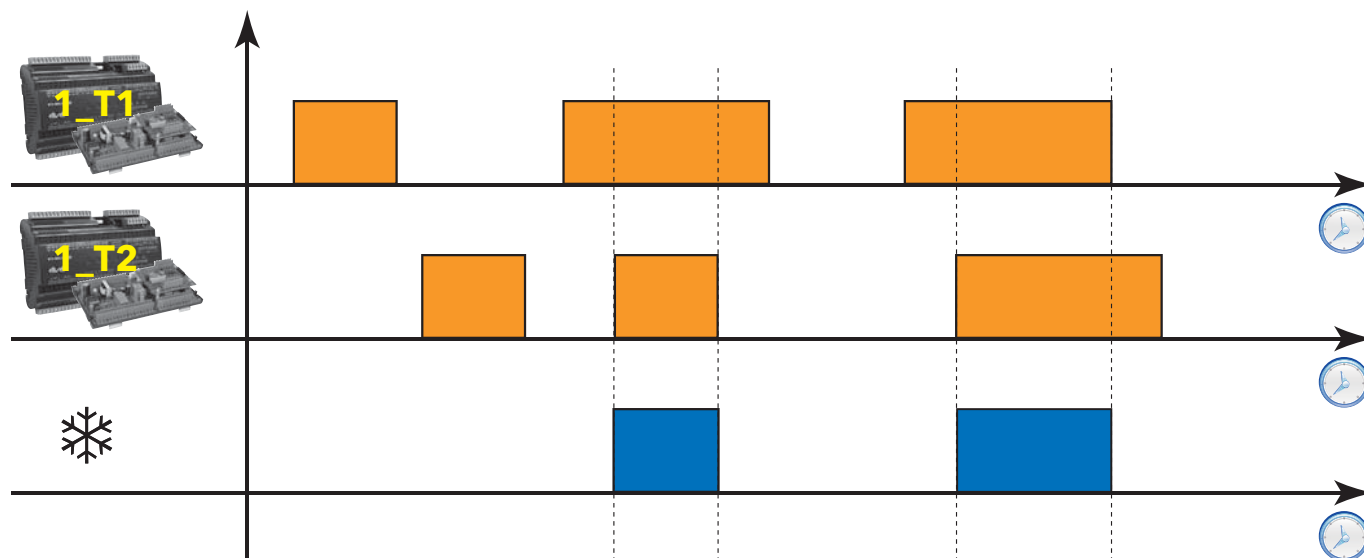

### 5.3.2.3 - Double "parallel" thermostat

This regulator activates cold/hot only if both thermostats have been requested, and disables it when both thermostats have been satisfied. If one or both of the thermostats has a probe error, the regulation will use the probe error parameters. In the diagram below, **1\_T1** is the probe set as thermostat 1, and **1\_T2** is the probe set as thermostat 2.

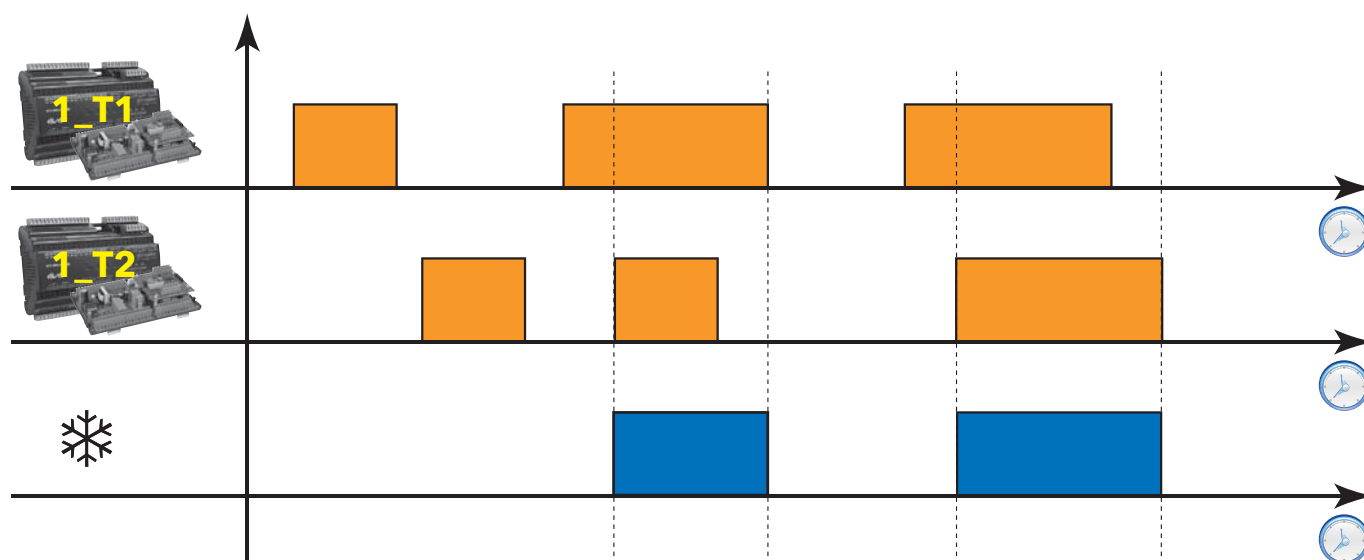



### 5.3.2.4 - Two power step regulation.

This regulator can be used in systems either with two compressors in parallel or one compressor with two power levels (partialised).

With this algorithm, the efficiency of the cabinet can be increased by running on just one step when a small quantity of power is required. The second step will be switched on when maximum power is required (start-up, after a defrost cycle, etc.),

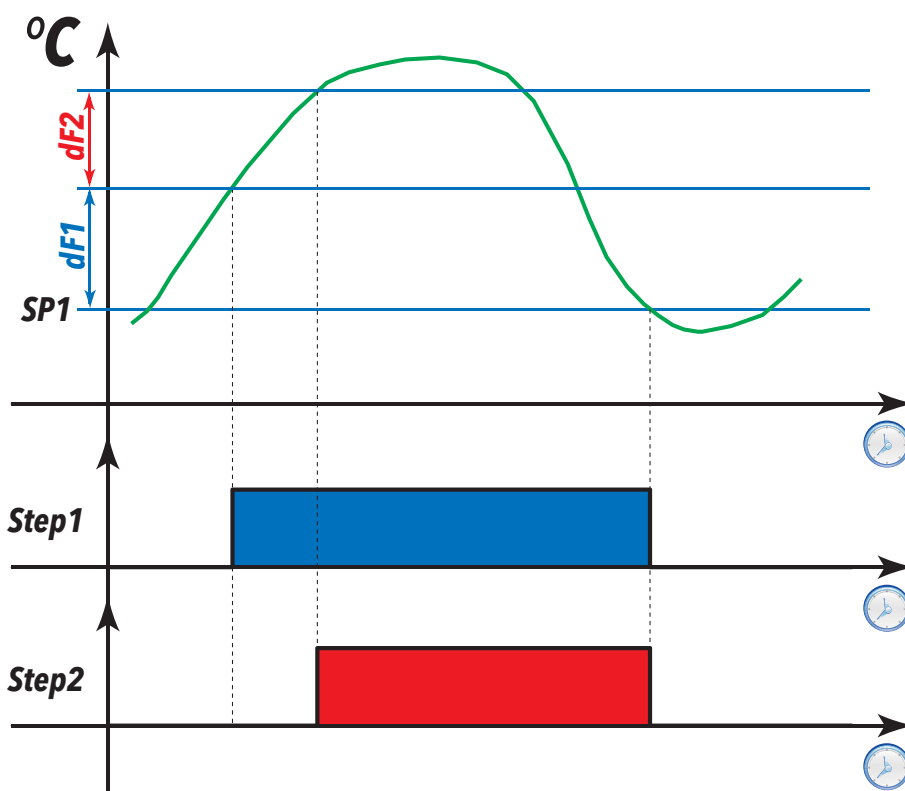

or rather when the controller senses that the first step is insufficient for reaching the setpoint, i.e., if the setpoint is not reached after the time **CS2** with only the first step on, then the second step will be switched on.

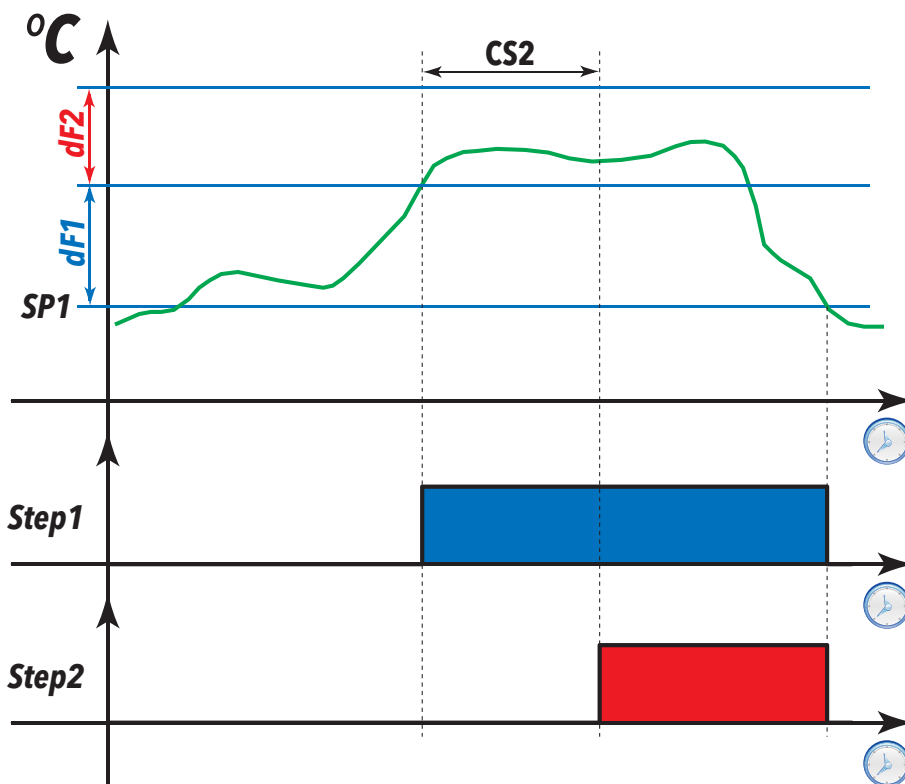



Both steps will be switched off when the setpoint is reached.

If the regulator demands the switching on of both power steps, the switch-on of the second step can be delayed, by means of parameter **CP2**, so as to mitigate the inrush current.

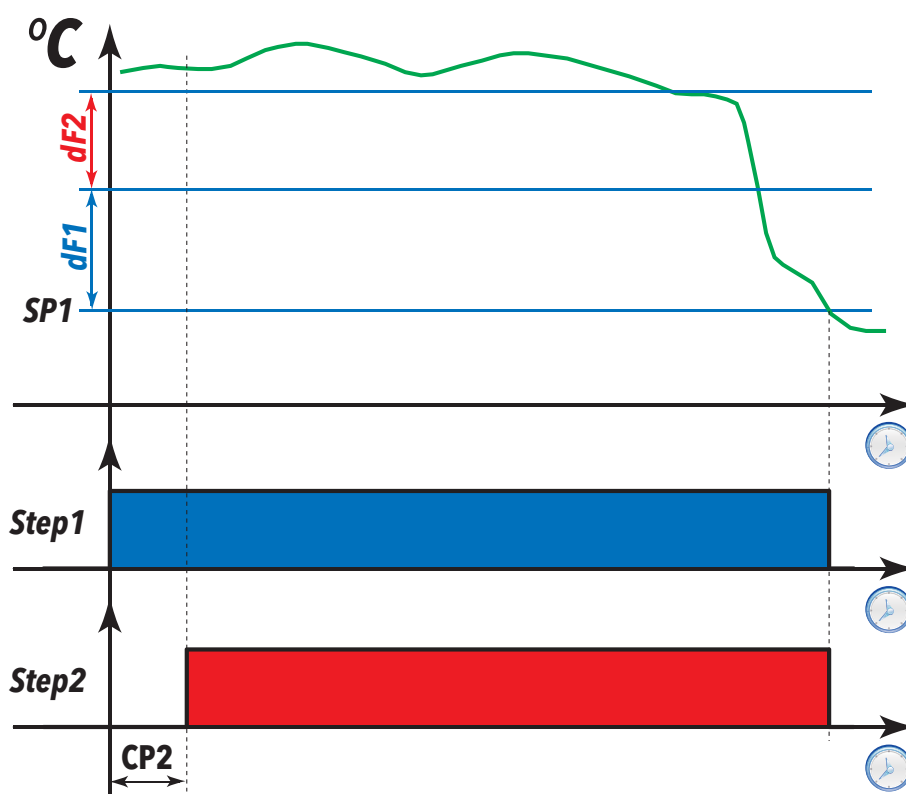

If two compressors are used, the following is possible:

- if **CC = 1**, the running hours of the two compressors will be balanced.
- if **CC = 0**, the switching on of the two outputs will always be sequential, starting with the first applicable one (e.g. in the case of one compressor with one partialisation).

The two compressor outputs are named **Compr n° 1** and **Compr n° 2**.

### 5.3.2.5 - Double compressor

In all the possible regulation modes, apart from two power step regulation, an additional compressor output can be controlled. This is enabled after a delay after the activation of the first output (**Compr n°1**), set by parameter **CP2**, and disabled at the same time as the first compressor.

This second output has no safety timer in that it follows immediately after the enabling of the first output and its associated safety timers.



### 5.3.2.6 - Auxiliary regulation

In addition to the standard regulator, an auxiliary regulator can be implemented by setting **rE = 4**. This regulator:

- Can function in both modes: HEAT and COOL.
- Has its own setpoint (**SP2**) and differential (**df2**).
- Has no safety timer, except for the time delay in **OdO**.
- In the event of a probe error, the output will always be OFF.

This regulator is independent from other regulations, with the exception of stand-by, where the output is set to OFF. The output associated to the regulator is: **Reg AUX**.

This regulator can be used, for example, to manage the light based on a light sensor connected to one of the five inputs Pb1... Pb5 (in this case, the setpoint and the differential, should be set according to the transcoding tables for compatible sensors. Contact Eliwell for assistance with choosing sensors and for transcoding tables).

### 5.3.2.7 - Regulation in the event of a probe error

If a probe error occurs for regulator 1, and/or regulator 2 when there is a double thermostat, the output will be managed in accordance with parameters **Ont** and **OFt**.

### 5.3.2.8 - Safety timing

Compressor on-off operations must respect the safety times that you can set using the special parameters as described below. The compressor LED will flash to indicate when an activate compressor request has been received but a safety protection exists. A safety time (compressor On... Off safety time) regulated by the parameter **dOF** must be respected between a switch-off and switch-on of the same compressor.

This waiting time also occurs at switch-on of the device. A safety time regulated by the parameter **dbi** must be respected between one switch-on and the next. The safety time set in parameter **dOn** must elapse between a start-up request and actual start-up.

Times set with parameters **dOn**, **dOF** and **dbi**, if active, are not accumulative but parallel.

The following diagram illustrates the operation of the compressor protection with parameters **dOn**, **dOF**, **dbi** set where:

<b>IN</b>	Input state for compressor regulator.
<b>OUT</b>	Output state for compressor regulator.

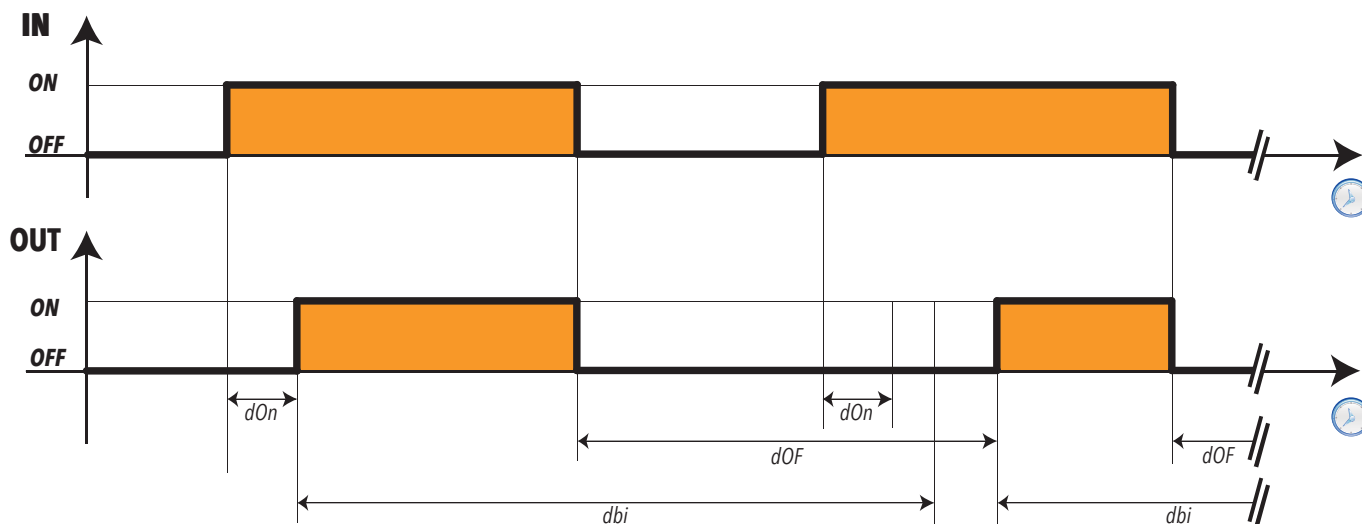



### 5.3.2.9 - Energy Saving

Energy saving mode can be activated in one of the following ways:

- From a digital input (when configured appropriately).
- From a key (when configured appropriately).
- By remote (from supervision system directly).
- Via RTC (when configured appropriately).
- Via LINK<sup>2</sup>.

In these modes, offsets **OS1** and **OS2** are added to regulation setpoints **SP1** and **SP2**. If the auxiliary regulator is active, the offset will also be added.

 **N.B.:** if you don't want the offset to be added to the auxiliary regulator as well, set **OS2** = 0.

In this mode, the value of the underlying differential will also be changed, **dF1** will be replaced by **dn1** and **dF2** by **dn2**. If the auxiliary regulator is active, the differential will also be added.

 **N.B.:** if you don't want to change the value of the differential in Energy Saving mode, just set **dn1** = **dF1**, and **dn2** = **dF2**.

### 5.3.2.10 - Dynamic Setpoint

If the dynamic setpoint is active (disabled though in Energy Saving mode), the setpoint in value **Od1** (for setpoint 1) and **Od2** (for setpoint 2) can be increased or decreased when the door remains closed for certain period of time (as defined in parameter **Cdt**). As soon as the door remains open longer than the time defined in **ESo** within an hour (not necessarily continuous but cumulative), the normal value of the setpoint is restored. The deactivation "threshold" can be set in parameter **ESo**. For example:

- **ESo = 0**: high use before deactivation.
- **ESo = 10**: low use before deactivation.

The function is active if parameter **Cdt** is different from zero and if a DI has been configured as door switch. If the auxiliary regulator is active, the offset will also be added.

 **N.B.:** if you don't want the offset to be added to the auxiliary regulator as well, set **Od2** = 0.

The diagram below shows how the algorithm works. The settings are:

- $ESt = 2$
- $H11 = 8$
- $ESF = yES$  (enabled if "Energy Saving" mode is active).

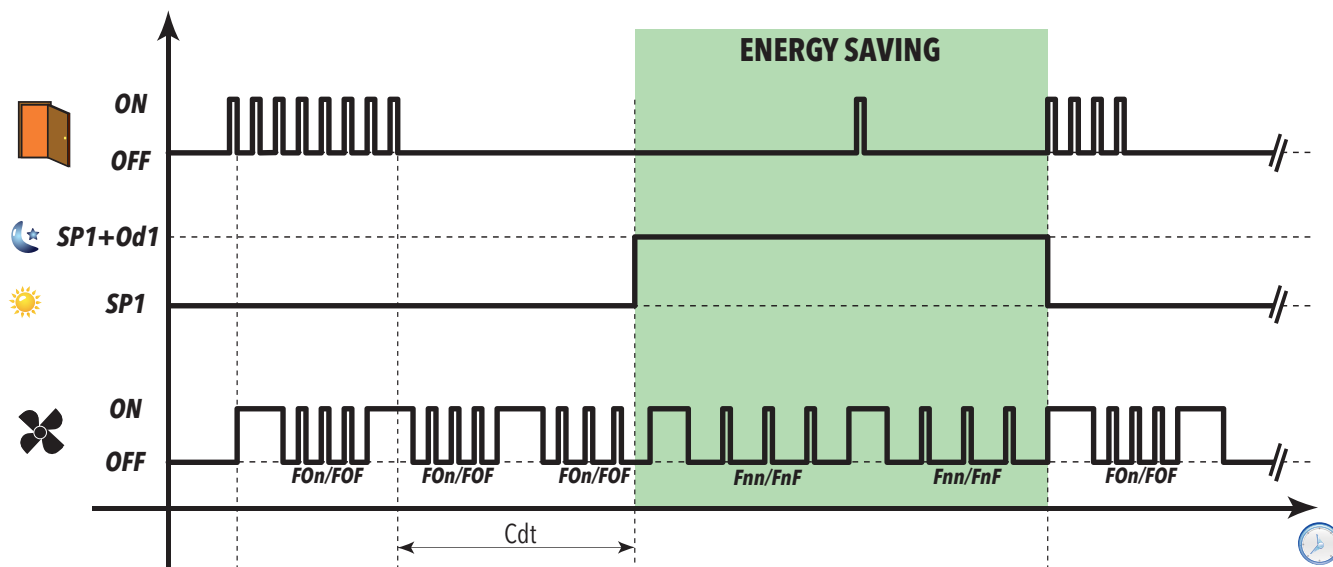



### 5.3.2.11 - Remote Offset (managed by Supervisor only)

Using the serial commands you can increase/decrease the current value of the regulation setpoint for quantity **OF1** (which is added to setpoint **SP1** and setpoint **OS1** or **Od1** if they have been set).



**CAUTION:** This increase/decrease only applies to the first setpoint (**SP1**).

This function is normally used for hot gas defrost installations where a certain number of counters must be chilling to assure there is enough hot gas for the defrost to be carried out effectively.

#### User parameters

The parameters that manage this regulator are:

Label	Description
rE	Sets the type of regulation to be implemented.
SP1	Temperature regulation setpoint.
dF1	Activation differential (absolute or relative).
SP2	Thermostat 2 temperature regulation setpoint.
dF2	Activation differential of the second thermostat (absolute or relative).
HC1	Thermostat 1 mode.
HC2	Thermostat 2 mode.
Ont	Controller switch-on time in the event of faulty probe.
OFt	Controller switch-off time in the event of a faulty probe.
dOn	Time delay to activate compressor output after request.
dOF	Time delay to activate compressor output after switching off.
dbi	Time delay between two consecutive switch ons of compressor output.
OdO	Delay in activating outputs after the instrument is switched on or after a power failure.
Cdt	Door close time.
ESo	Cumulative door opening time to disable Energy Saving mode.
OS1	Setpoint offset 1.
OS2	Setpoint offset 2.
Od1	Energy Saving Offset 1 glass door display cabinets.
Od2	Energy Saving Offset 2 glass door display cabinets.
dn1	Activation differential 1 in energy saving mode.
dn2	Activation differential 2 in energy saving mode.



### 5.3.3 - COMPRESSOR/GENERAL PROTECTIONS

#### Description

If the cold room probe is in error "E1", the relay of the output configured as compressor/general regulates in line with the timings set in parameters **Ont** and **Oft**.

The first time to consider is **Ont**.

If **Ont > 0**, the protection programmed in parameters

**dOn-dOF-dbi** must however be observed (see compressor safety timings).



**NOTE:** You are reminded that parameter **Odo** inhibits the activation of all outputs commanding a relay for its entire duration (compressor/general, defrost, fans), excluding buzzers or alarm relays.

#### Operating conditions

The table below lists the ways the compressor relay output can be managed:

Ont	Oft	Compressor OUT
0	0	OFF
0	>0	OFF
>0	0	ON
>0	>0	DUTY CYCLE

If **Ont > 0** and **Oft = 0**: the compressor regulator will always be active.

If **Ont > 0** and **Oft > 0**: the compressor regulator activates in operating cycle mode irrespective of the values of probes (cold room probe failure) and requests from other utilities (**Duty Cycle**) mode.

If the cabinet probe is working properly, the Duty Cycle mode does **NOT** activate as it does not have priority over normal compressor regulator settings.

The following diagram shows the **Duty Cycle** operating mode based on parameters **Ont** and **Oft > 0**:

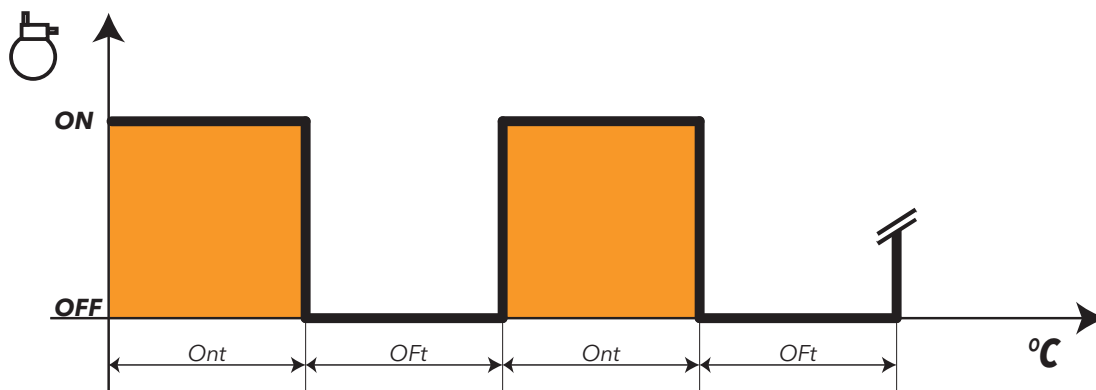



### 5.3.3.1 - Compressor safety times

Compressor on-off operations must respect the safety times that you can set using the special parameters as described below. The compressor LED will flash to indicate when an activate compressor request has been received but a safety protection exists. A safety time (compressor On... Off safety time) regulated by the parameter **dOF** must be respected between a switch-off and switch-on of the same compressor. This waiting time also occurs at switch-on of the device.

A safety time regulated by the parameter **dbi** must be respected between one switch-on and the next.

The safety time set in parameter **dOn** must elapse between a start-up request and actual start-up.

Times set with parameters **dOn**, **dOF** and **dbi**, if active, are not accumulative but parallel.

The following diagram illustrates the operation of the compressor protection with parameters **dOn**, **dOF**, **dbi** set where:

<b>IN</b>	Input state for compressor regulator.
<b>OUT</b>	Output state for compressor regulator.

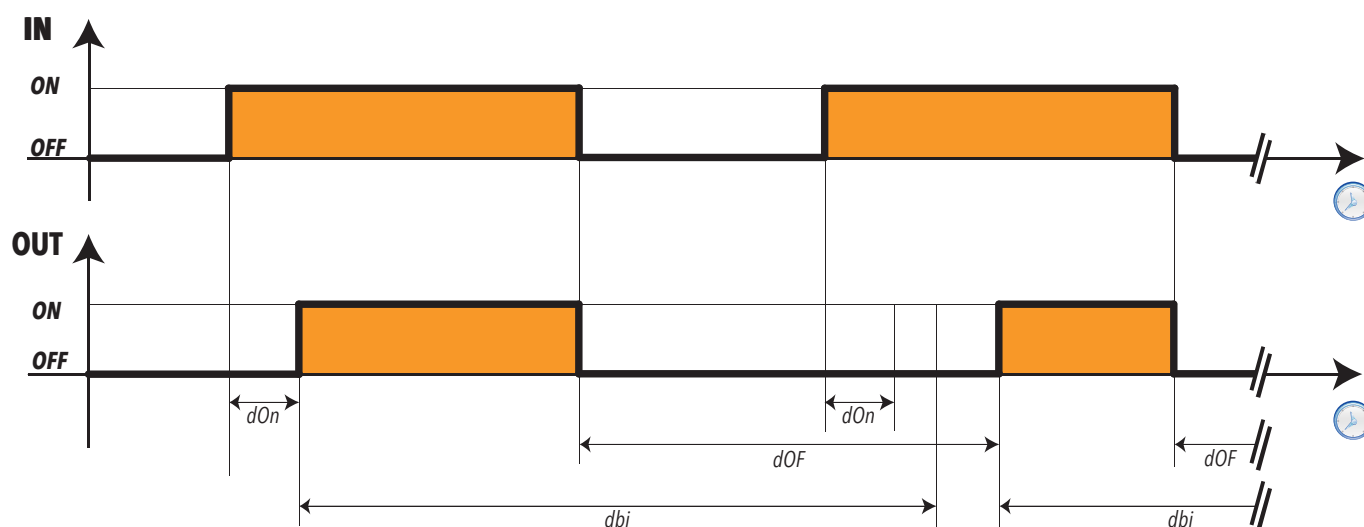

**NOTE:** See the section entitled Compressor Function During Defrost for other safety measures and compressor timings.

### User parameters

The parameters that manage this regulator are:

Label	Description
Ont	Compressor output ON time in the event of a faulty Pb1 probe
Oft	Compressor output OFF time in the event of a faulty Pb1 probe
dOn	Compressor output enabling delay from request
dOF	Compressor output enabling delay from shutdown
dbi	Delay between two consecutive starts of the compressor output
OdO	Delay output enabling from power-on





## 5.3.4 - DEFROST/COIL DRAINAGE

### 5.3.4.1 - Enable defrost

Defrost is used to stop ice from forming on the surface of the evaporator.

This can be **activated**:

- Automatically, in one of the following modes as set in **dCt**:
  - Compressor hours (Digifrost).
  - Device hours.
  - Compressor stop.
  - By clock time (see the relative RTC section below).
  - By probe (this does not apply in double evaporator systems).
- Via LINK<sup>2</sup>.
- From DI.
- From a key.
- By remote.

The **type** of defrost can be selected from parameter **dtY** and can be:

- 1) Defrost by electrical heater.
- 2) Defrost by electrical heater. Smart Defrost.
- 3) Reverse cycle.
- 4) Hot gas for plug-ins.
- 5) Hot gas for counters with remote unit.

### Coil drainage

On completion of defrost, given that there will be water on the evaporator, it is better not to start "cooling" right away as this would ruin the effect of the defrost by creating ice immediately.

The drainage interval is regulated via parameter **dt**.

### Defrost conditions and function

Defrosting is enabled if:

- The evaporator temperature, read by probe 2, is less than the end defrost time set in parameter **dSt**.
- Manual defrosting has not already been activated, in which case the request for automatic defrost will be cancelled.

Defrost requests can be made in the following ways:

Controller power-on	If parameter <b>dPO</b> (defrost at power-on) is programmed accordingly
Time interval	If <b>dit</b> > 0 whenever the defrost time interval set in parameter <b>dit</b> elapses
Manually (from a key).	By pressing key  if enabled (H31 = 1). When <b>OdO</b> ≠ 0 the cycle does not start, the request is rejected and the display blinks three times to indicate that defrost is not possible.
External request via D.I.	If D.I. appropriately configured. Activation from D.I. respects the protections of the automatic cycle. When <b>OdO</b> ≠ 0 the cycle does not start, the request is rejected and the display blinks three times to indicate that defrost is not possible.



### 5.3.4.2 - Automatic defrost

The defrost cycle is programmed to start at intervals.

 **NOTE:** To disable the automatic cycle, set **dit**=0.

If **dit**>0, defrosts will take place at fixed intervals as set in parameter **dit** and the interval time is calculated as follows:

Parameter	Value	UM	Description	Note
	<b>0</b>	num	Defrost disabled	
<b>dCt</b>	<b>1</b>	num	Compressor running hours (DIGIFROST® method)	In this case, the counter runs only if the compressor is on. A new count starts when the defrost interval elapses and a new defrost cycle starts if conditions permit. <b>NOTE:</b> compressor running time is counted separately from the internal evaporator temperature. If the evaporator probe is missing or faulty, the count will always activate during the compressor on time.
	<b>2</b>	num	Controller running time	The defrost time interval is counted continuously when the controller is on and starts at each power-on. A defrost cycle starts when the defrost interval elapses (indicated by dit) if conditions permit and the controller immediately starts counting a new defrost interval.
	<b>3</b>	num	Compressor stop	Every time the compressor stops, a defrost is carried out in the mode set in parameter <b>dy</b> .
	<b>4</b>	num	RTC (clock)	The following can be set using the clock: <ul style="list-style-type: none"> <li>• Defrost times (<b>6</b> time bands on weekdays and <b>6</b> bands for weekends and public holidays).</li> <li>• Periodical defrost (every <b>n</b> days).</li> <li>• Daily events (<b>1</b> event for weekdays and <b>1</b> event for weekends and public holidays).</li> </ul> Time band defrosts and periodic defrost operate in a mutually exclusively way (they do not operate at the same time). If defrost by RTC has been enabled and the clock has failed, the defrost will run according to the mode set in <b>dit</b> (provided <b>≠ 0</b> ).
	<b>5</b>	num	Temperature	Defrost activates when the evaporator temperature drops below the <b>dSS</b> threshold. If probe dP1 fails, defrost activates on the basis of interval <b>dit</b> .

 **CAUTION:** in all interval count modes, the following conditions apply:

If the time delay set in **OdO** is under way or if the evaporator probe temperature is greater than **dS1**, then the conditions for defrost have not been fulfilled: another count will commence and only on completion of this new count will the start defrost conditions be tested again.

### 5.3.4.3 - Manual defrost

If you press the manual defrost key  (or from Digital Input if configured with **H11 ... H18 = 1**), the device will start defrost. Procedures for the activation of this defrost cycle are the same as for external defrost.

The defrost interval count proceeds as described earlier under Automatic Defrost (time **dE1** is not cleared and allowed to continue).

If the conditions to start defrost have not been fulfilled, i.e.:

- The time set in parameter **OdO** has not elapsed.
- The evaporator temperature is greater than the value set in parameter **dS1**.

this will be signalled on the display (screen flashes three times) and defrost will stop.

Manual defrost is always enabled except when **dit** = 0.



### 5.3.4.4 - External Defrost

If the Digital Input has been configured for this function (if **H11 ... H18 = 1**), a defrost request can be made and the relative regulator activated if the necessary conditions have been fulfilled.

Time graphs for signals in each of the various function modes are presented below.



**CAUTION:** The defrost activates on the leading edge of the signal (toggle) and the polarity can be selected. Hence you can only activate a defrost, NOT stop one that is underway. Defrost or dripping currently under way and the count of defrost or dripping time cannot be suspended.

<b>IN (Digital Input)</b>	Input state for defrost regulator, with activation from Digital Input.
<b>OUT (Defrost)</b>	Output state for defrost regulator.
<b>DurDI</b>	Digital Input duration.
<b>N.B.:</b>	<b>dS1</b> indicates the time to end of defrost and to reach setpoint temperature, whereas <b>dE1</b> indicates the end of defrost time-out.

The control diagram is as follows:

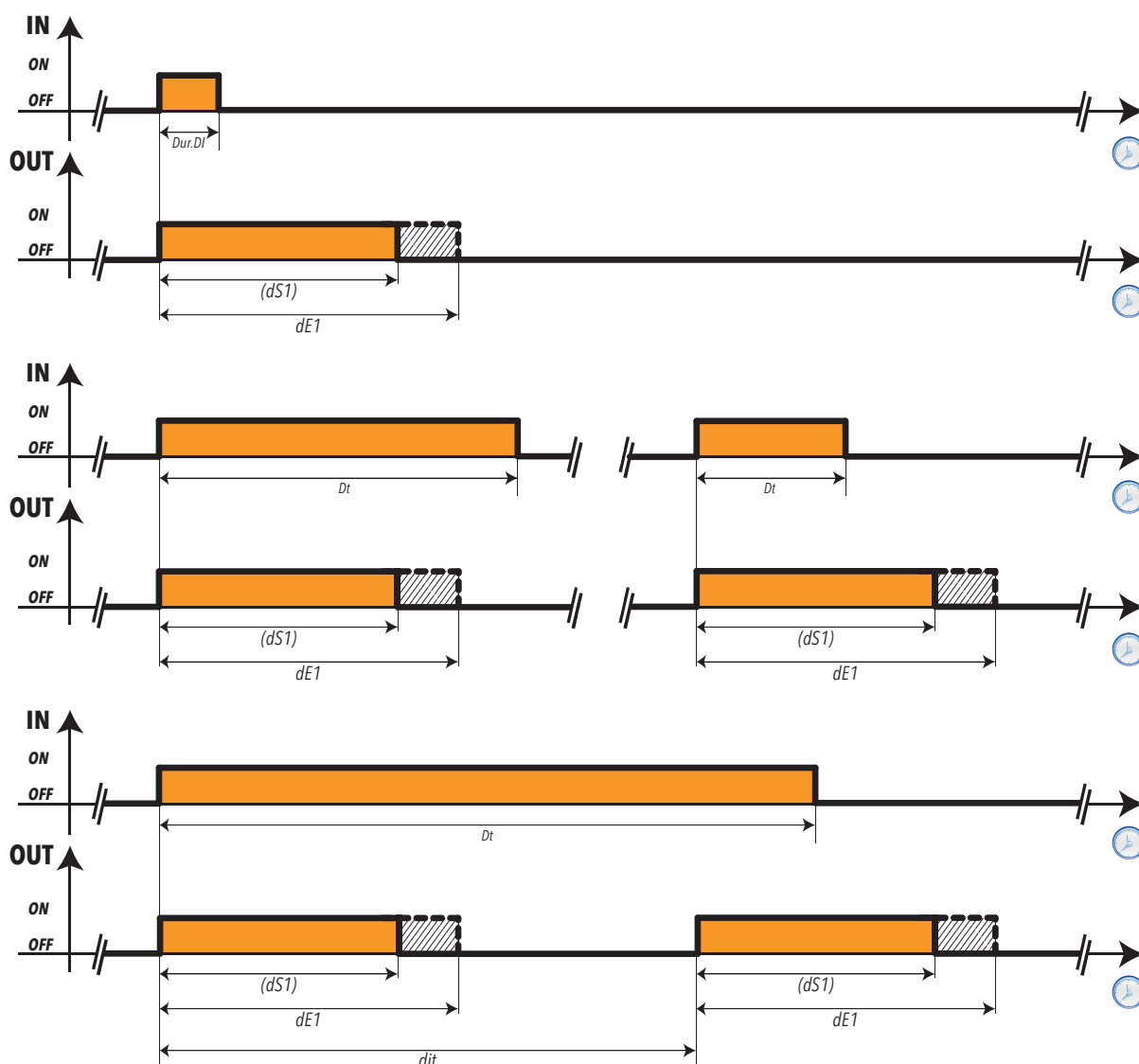



### 5.3.4.5 - Defrost mode

#### Defrost by electrical heater

Defrost with electrical heaters is configured by setting **dtY = 0**. It is used in "LOW TEMPERATURE" applications.

The compressor stops for the duration of the defrost cycle and the relay configured as defrost regulator output, and that the electrical heaters are connected to, activates. On completion of defrost, the heaters will be switched off and the compressor will stop for the dripping time set in parameter **dt** if different from zero.

Defrost ends due to:

Evaporator Probe (dP1)	End of defrost description
dP1 ABSENT	For time-out set in parameter <b>dE1</b> (defrost time-out)
dP1 PRESENT	On reaching end of defrost temperature setpoint configured in parameter <b>dS1</b> . If this setpoint is not reached by the time set in parameter <b>dE1</b> (defrost time-out), the defrost will stop due to time-out.

#### N.B.:

- If **dS1** activates before **dE1**, dripping (**dt** and **Fdt**) behaves as set in **dS1**.
- If **Fdt < dt**, the setting is **Fdt = dt**.
- During defrost, fans are OFF if parameter **dFd** is set accordingly, otherwise they will behave as set for the fan regulator.

The operating diagram is as follows:

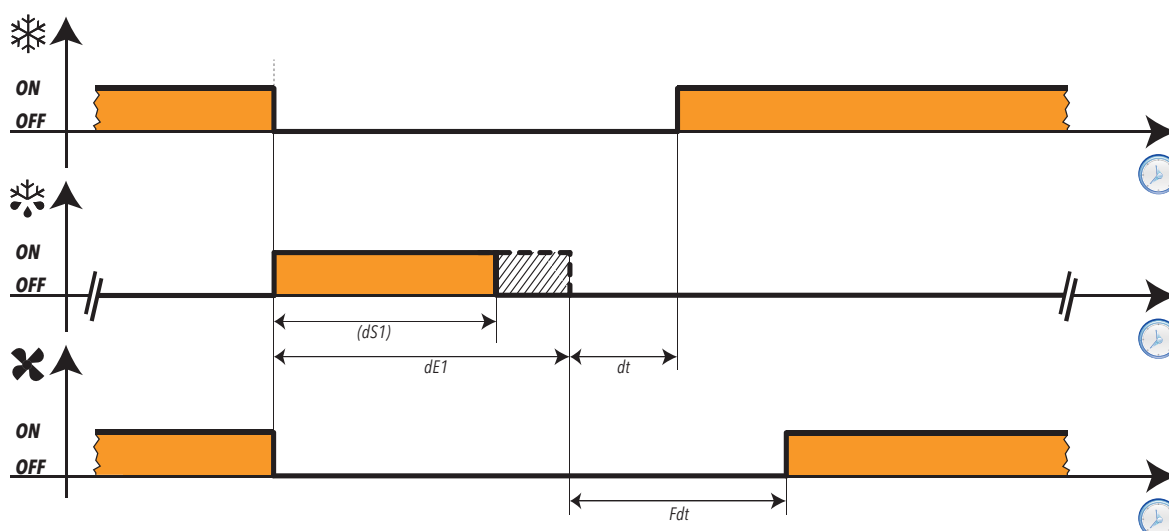

Legend:

	Output state for <b>compressor</b> regulator
	Output state for <b>defrost</b> regulator
	Output state for <b>evaporator fans</b> regulator



## Defrost by electrical heater: Smart Defrost.

This algorithm optimizes defrost by using heaters.

This algorithm can be used to reduce the end of defrost setpoint as compared to the standard mode; the controller modulates the heaters appropriately and detects if the ice has fully melted, and therefore if defrost can be stopped (before time-out **dE1**).



- N.B.:**
- This algorithm applies to both single and double evaporation applications.
  - The function is active if **dtv = 4** and stops within time (**dE1**) or at temperature (**ds1**).

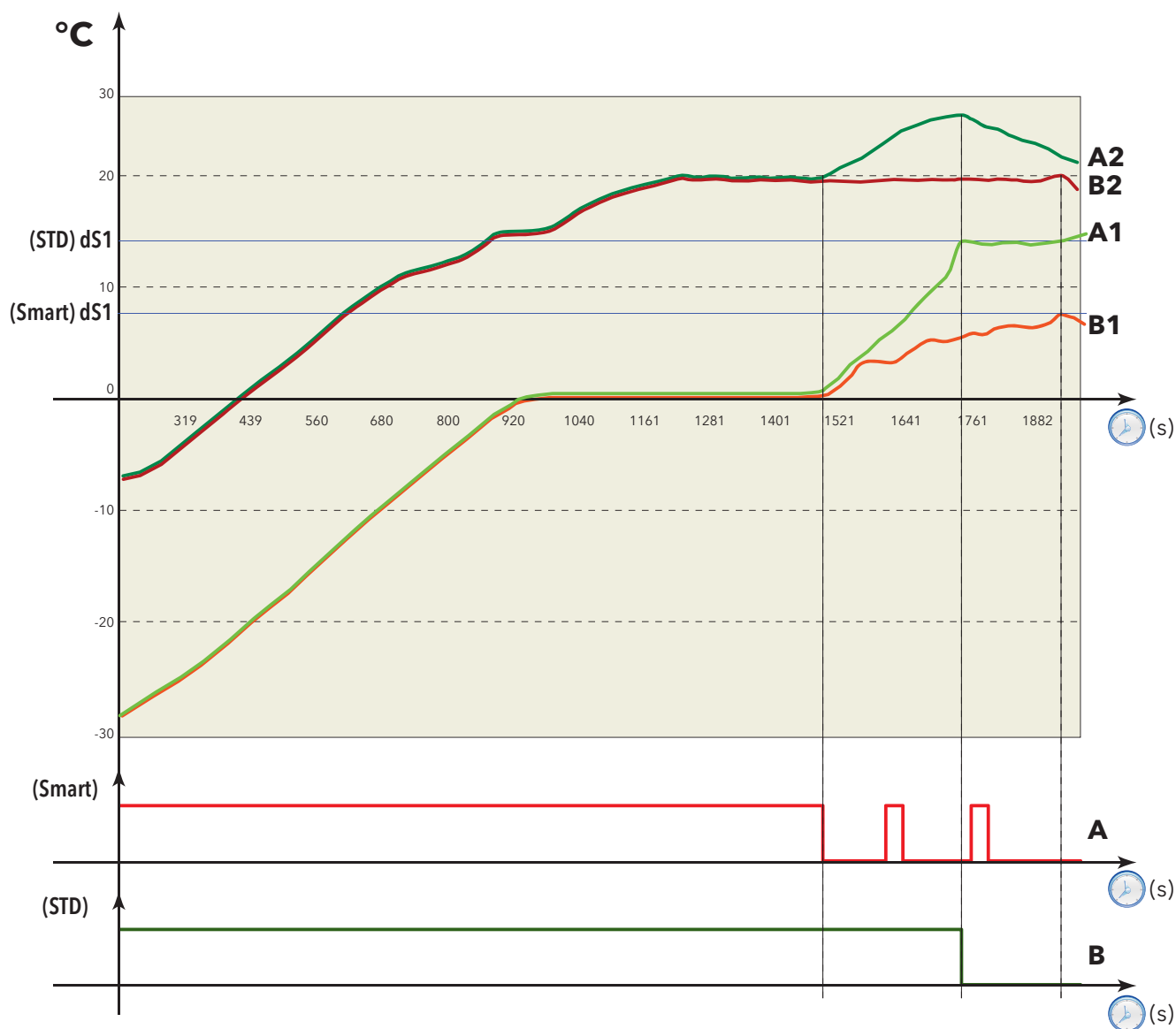

The meaning of each of the letters in the graph is provided in the table below:

Key	Description of Curve
<b>A</b>	"Standard Defrost" Relay Activation
<b>A1</b>	"Standard Defrost" Evaporator Temperature
<b>A2</b>	"Standard Defrost" Counter Temperature
<b>B</b>	"Smart Defrost" Relay Activation
<b>B1</b>	"Smart Defrost" Evaporator Temperature
<b>B2</b>	"Smart Defrost" Counter Temperature

The configuration of this mode is similar to traditional defrost.

The time-out to be set is the same, whereas the end of defrost setpoint can be reduced.



## Reverse cycle defrost

Hot gas defrost is configured by setting parameter **dtY = 1**. It is used in "LOW TEMPERATURE" applications.

The compressor stays on for the entire duration of the defrost cycle and the relay configured as defrost regulator output, and that the solenoid valve is connected to, activates.

On completion of the defrost cycle, the solenoid valve relay is de-energized and the coil drainage phase set in parameter **dt** (if not equal to zero) is interrupted. The compressor relay is once again controlled by the compressor regulator.

Defrost ends due to:

Evaporator Probe (dP1)	End of defrost description
dP1 ABSENT	For time-out set in parameter <b>dE1</b> (defrost time-out)
dP1 PRESENT	On reaching end of defrost temperature setpoint configured in parameter <b>dS1</b> . If this setpoint is not reached by the time set in parameter <b>dE1</b> (defrost time-out), the defrost will stop due to time-out.



**CAUTION:** Parameters **dOn**, **dOF** and **dbi** always take priority however.

### NOTES:

- If **dS1** activates before **dE1**, dripping (**dt** and **Fdt**) behaves as set in **dS1**.
- If **Fdt** < **dt**, the setting is **Fdt = dt**.
- During defrost, fans are OFF if parameter **dFd** is set accordingly, otherwise they will behave as set for the fan regulator.

The operating diagram is as follows:

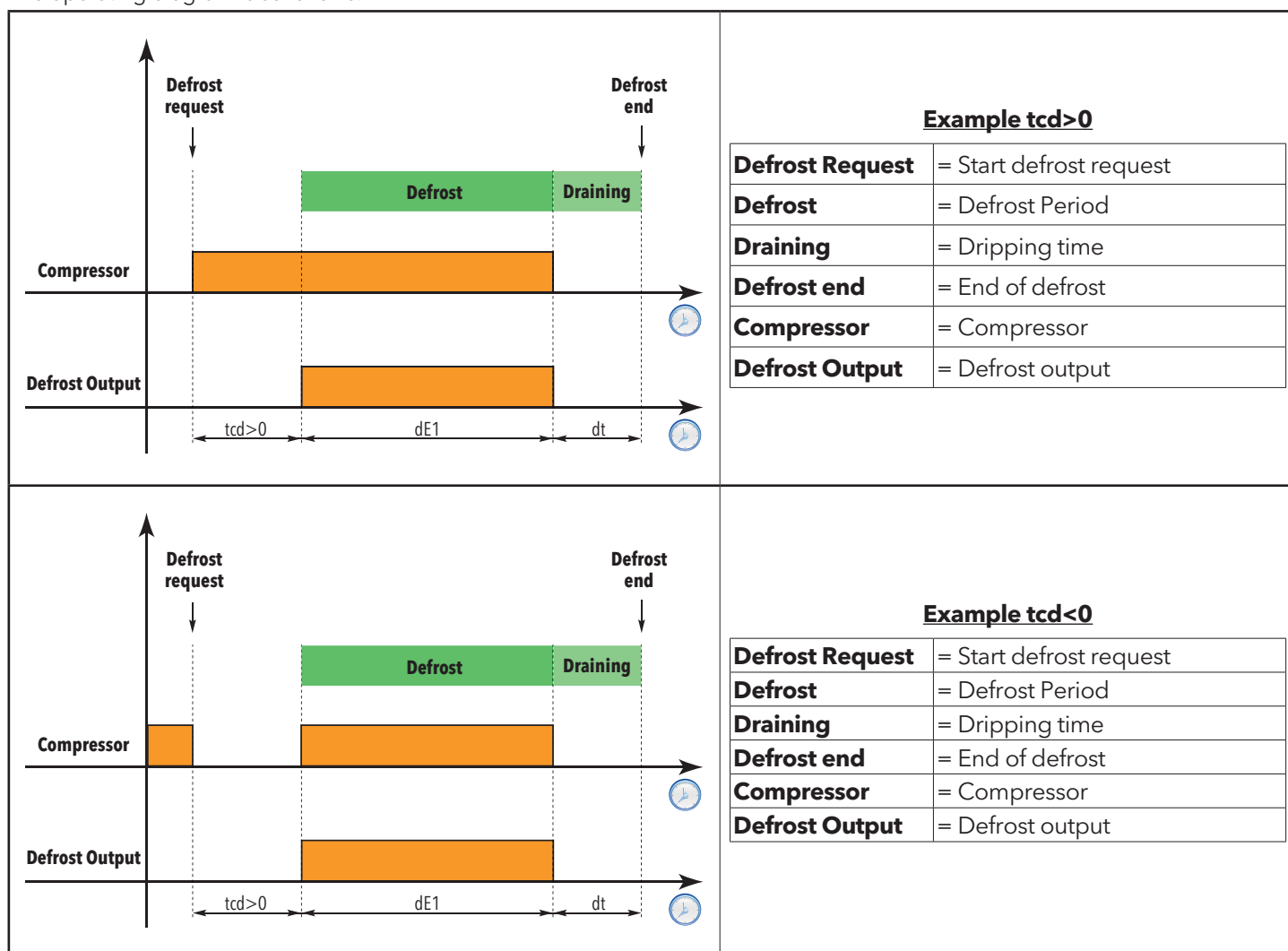



## Hot gas defrost for plug-in systems

The hot gas defrost for **PLUG-IN** systems differs from the reverse cycle defrost in that the gas must be heated up appropriately before starting defrost.

The defrost cycle comprises the following phases (or a sub-group of them):

- **Deep-cooling:** gas heated and cold built up in counter for time set in **tdC** > 0.
- **Pump-down:** evacuation of cold gas in evaporator, for the time set in **tPd** > 0.
- **Defrost:** injection of hot gas for time of between **ndE** and **dE1**.
- **Dripping:** completion of "evacuation" of water from evaporator (for time set in **dt**).

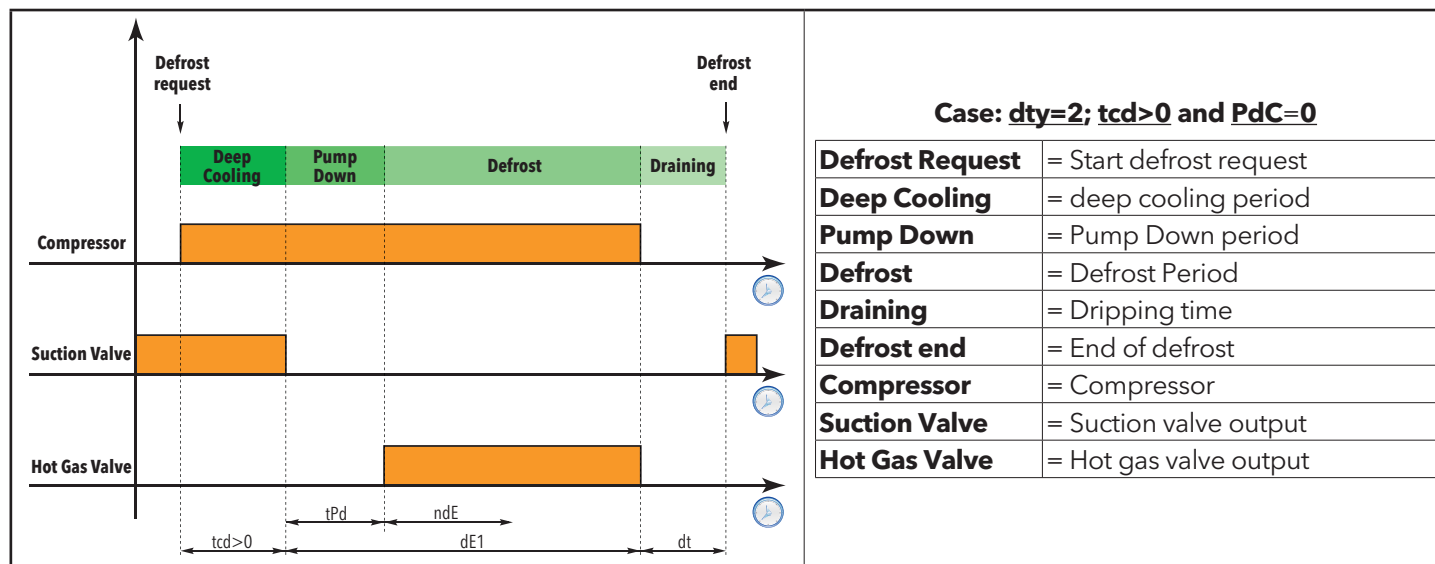

During the entire defrost phase:

- (if present and enabled) the EEV valve output is off (OFF).
- The fans are off (OFF).

## Hot gas defrost for systems with remote unit

Hot gas defrost in **REMOTE-CONTROLLED** systems requires the following phases (or sub-groups of them):

- **Pump-down:** evacuation of cold gas in evaporator (parameter **tdC** > 0).
- **Defrost:** Injection of hot gas (for a time between **ndE** and **dE1**).
- **Dripping:** completion of "evacuation" of water from evaporator (for time set in **dt**).
- **Pump-down:** evacuation of hot gas in evaporator, for time set in **PdC**.
- **Regulation:** if necessary, valve EEV reactivated.

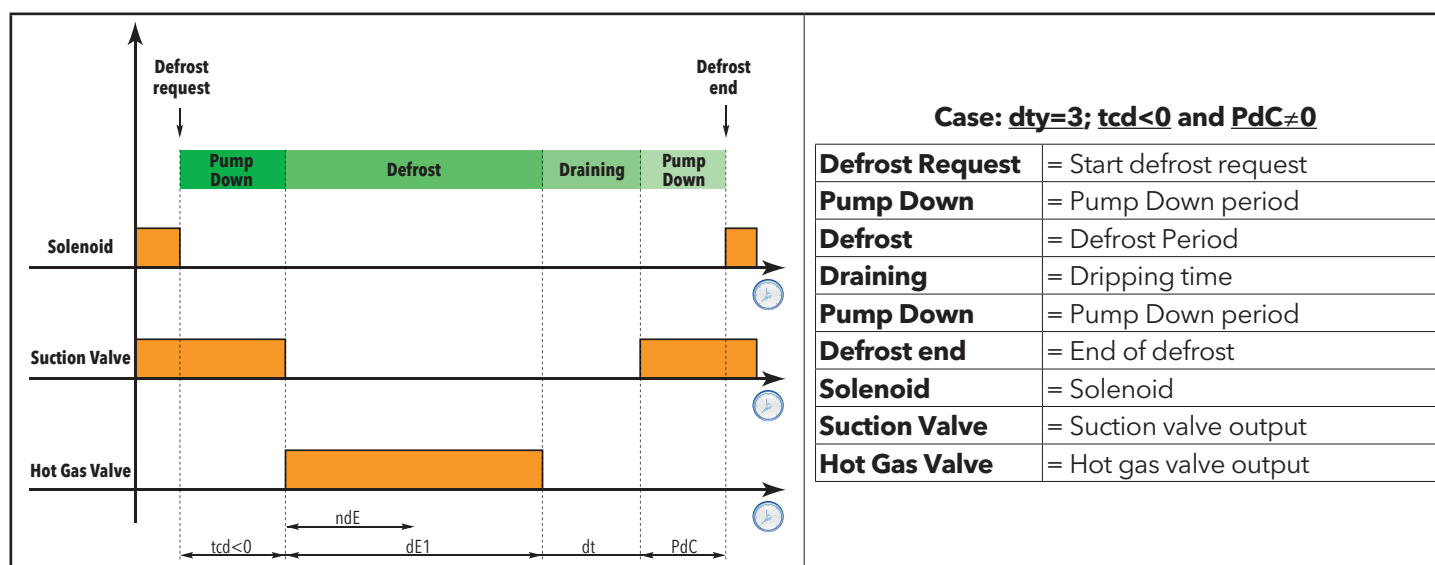

During the entire defrost phase:

- (if present and enabled) the EEV valve output is off (OFF).
- The fans are off (OFF).



## Double evaporator defrost

In double evaporator applications, defrost can be optimized using a probe and an output for each evaporator; this optimizes the heating phase for each evaporator in line with actual requirements.



- N.B.:**
- 1) This mode is active if at least two outputs have been configured as defrost (evap. 1 and evap. 2).
  - 2) Each evaporator has its own end of defrost tie and time-out.

The decision regarding the fulfilment or otherwise of defrost conditions (temperature below threshold), given that there are two sensors (one per evaporator) can be made in one of the following ways:

- **dFt = 0:** check that only evaporator 1 sensor (**dP1**) is below threshold **dS1**.
- **dFt = 1:** at least one evaporator has fulfilled defrost conditions. Evaporator 1 defrost probe (**dP1**) is below threshold **dS1** e/o evaporator defrost probe 2 (**dP2**) is below threshold **dS2**.
- **dFt = 2:** both evaporators have fulfilled defrost conditions. Evaporator 1 defrost probe (**dP1**) is below threshold **dS1** and evaporator defrost probe 2 (**dP2**) is below threshold **dS2**.

The defrost of each evaporator stops when the following conditions are fulfilled:

- Time-out **dE1/dE2** has elapsed.
- Temperature **dS1/dS2** reached.



**NOTE 1:** The count of dripping time starts when both evaporators have stopped defrosting.



**NOTE 2:** If necessary, two sensors and one defrost output can be used as a control.  
EXAMPLE: double evaporator, each with its own probe but shared defrost, or one evaporator with two sensors (fixed in two different positions).

## User parameters

The parameters that manage this regulator are:

Label	Description
dy	Selects defrost type
dit	Time interval between 2 consecutive defrost cycles
dCt	Selects the count mode for the defrost interval
dOH	Delay in activating defrost cycle after request
dE1	Evaporator 1 defrost time-out. Determines the maximum defrost duration
dE2	Evaporator 2 defrost time-out. Determines the maximum defrost duration
dS1	End of defrost temperature 1 - determined by evaporator 1 probe
dS2	End of defrost temperature 2 - determined by evaporator 2 probe
dSS	Start defrost temperature threshold (only if <b>dCt = 5 - temperature</b> )
dPO	Determines whether the instrument must enter defrost mode at power-on
Fdt	Delay in activating fans after a defrost cycle
dt	Coil drainage time
dFd	Allows exclusion of the evaporator fans to be selected or not selected during defrosting
dAO	Temperature alarm disabling time after defrost cycle
dAt	Alarm signalling end of defrost due to timeout
ddL	Display mode during defrost cycle (lock display)
dSE	Temperature threshold to start defrost
Ldd	Timeout value for display unlock - label dEF





## 5.3.5 - EVAPORATOR FANS

### 5.3.5.1 - Operating conditions

The regulator is activated provided that:

- The time set in parameter **OdO** has elapsed.
- The temperature of the evaporator probe is less than the value set in parameter **FSt**.
- It hasn't been excluded during defrost by parameter **dFd (dFd = On)**.
- Dripping is not active (**dt**).
- Fan delay after defrost has not been implemented (**Fdt**).

The request to switch fans on or off can be made in the following ways:

- by the compressor regulator to help in the "cooling" process (temperature control mode)
- by the defrost regulator to check and/or limit the diffusion of hot air

	FCO	DAY		NIGHT (Energy Saving)	
		Compressor ON	Compressor OFF	Compressor ON	Compressor OFF
Probe present and working	0	THERMOSTATCONTROLLED	OFF	THERMOSTATCONTROLLED	OFF
	1	THERMOSTATCONTROLLED	THERMOSTATCONTROLLED	THERMOSTATCONTROLLED	THERMOSTATCONTROLLED
	2	THERMOSTATCONTROLLED	THERMOSTATCONTROLLED	THERMOSTATCONTROLLED	THERMOSTATCONTROLLED
	3	THERMOSTATCONTROLLED	DUTY CYCLE DAY	THERMOSTATCONTROLLED	DUTY CYCLE NIGHT
	4	THERMOSTATCONTROLLED	INV DUTY-CYCLE DAY**	THERMOSTATCONTROLLED	INV DUTY-CYCLE NIGHT**
Probe present but in error	0	DUTY CYCLE DAY	OFF	DUTY CYCLE NIGHT	OFF
	1	ON	OFF	ON	OFF
	2	DUTY CYCLE DAY	DUTY CYCLE DAY	DUTY CYCLE NIGHT	DUTY CYCLE NIGHT
	3	DUTY CYCLE DAY	DUTY CYCLE DAY	DUTY CYCLE NIGHT	DUTY CYCLE NIGHT
	4	DUTY CYCLE DAY	DUTY CYCLE DAY	DUTY CYCLE NIGHT	DUTY CYCLE NIGHT
Probe absent	0	ON	OFF	ON	OFF
	1	ON	ON	ON	ON
	2	DUTY CYCLE DAY	DUTY CYCLE DAY*	DUTY CYCLE NIGHT	DUTY-CYCLE NIGHT*
	3	ON	DUTY CYCLE DAY*	ON	INV DUTY-CYCLE NIGHT**
	4	ON	INV DUTY-CYCLE DAY**	ON	INV DUTY-CYCLE NIGHT**

\* see section on "Fan function when probe Pb2 is absent" (H42 ≠ 0).

\*\* Function is the opposite of normal Duty-Cycle

Graphs explaining fan function based on the value of **FCO** are provided below.  
In the graphs you will see:

Legend:

<b>DAY</b>	Day
<b>NIGHT</b>	Night (Energy Saving)
<b>COOL</b>	Cooling
<b>Probe OK</b>	Fan function with the probe present and working
<b>Probe KO</b>	Fan function with the probe present but in error





### 5.3.5.2 - Fan function in temperature control

During "cooling", the fans operate as shown in this diagram:

Thermostat control of fans takes place at the values set in parameters

- **FSt** (fans disabling temperature) and **FAd** (fans differential).

The block fan temperature set by parameters **FSt** (fan block temperature) and **FAd** (fan differential) is an absolute value since **FPt = 0** (actual temperature value).



**CAUTION:** On nearing the start fan temperature (-50°C), the differential will always refer to parameter **FAd** but with the opposite sign.

The fan regulator operates as indicated below:

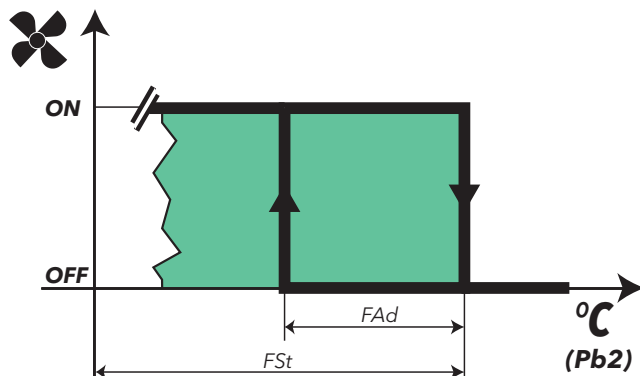

The regulation probe can be:

- Single for normal regulation and defrost (**FP1** ≠ 0 and **FP2** = 0).
- A specific probe for regulation and one during defrost (**FP1** ≠ 0 and **FP2** ≠ 0).

The fans can be excluded:

- During defrost
- If a digital input has been configured as door switch.

When evaporator fans are enabled during defrost (**FdF** = ON) and the relative probe is in error, the fans are all switched on. If the evaporator probe is not present and **FdF** = ON, the evaporator fans are active during defrost.

Energy Saving mode (night) is only active if enabled by parameter **ESF** (obviously when the controller is in Energy Saving mode).



### 5.3.5.3 - Fan function in Duty Cycle

There are two Duty Cycle modes: **Day** and **Night** (Energy Saving).  
The activation of **Night** mode depends on parameter **ESF**:

<b>ESF = n</b>	<b>Night</b> mode disabled
<b>ESF = y</b>	<b>Night</b> mode active when Energy Saving mode is active

Duty Cycle operation depends on the operating mode, e.g.:

- **Day**: parameters **Fon** and **FoF** must be set appropriately.
- **Night**: parameters **Fnn** and **FnoF** must be set appropriately.

The fans operate as follows:

DUTY CYCLE DAY			DUTY CYCLE NIGHT		
Fon	FoF	Fan operation	Fnn	FnF	Fan operation
0	0	OFF	0	0	OFF
0	≠0	OFF	0	≠0	OFF
≠0	0	ON	≠0	0	ON
≠0	≠0	DUTY CYCLE DAY	≠0	≠0	DUTY CYCLE NIGHT

The fan regulator will run in Duty Cycle mode as shown below:

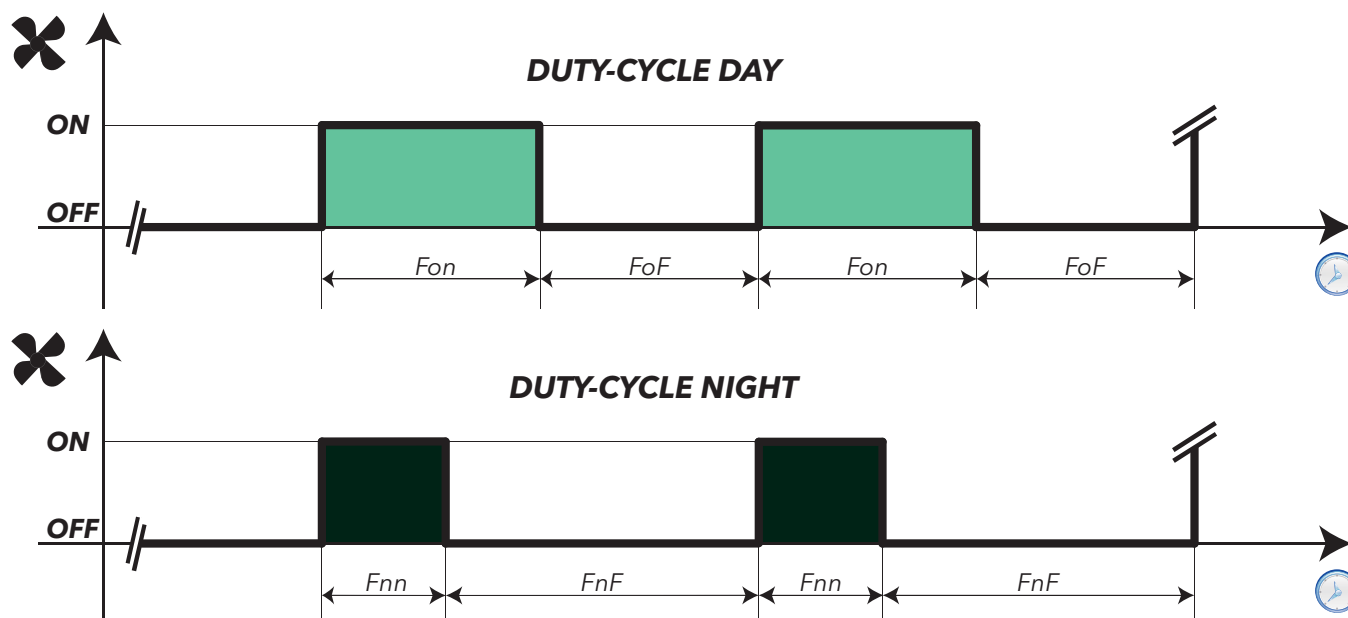

### 5.3.5.4 - Fan function during defrost

During defrost, the fans operate as shown in this diagram

<b>dFd = OFF</b> Exclusion of fans during defrost	<b>OFF</b>
<b>dFd = On</b> : the fans are not excluded during defrost (see parameters <b>FCO</b> , <b>Fon</b> , <b>FoF</b> , <b>Fnn</b> and <b>FnF</b> )	<b>TEMPERATURE CONTROL / DUTY-CYCLE</b>

Thermostat control of fans takes place at the values set in parameters:

- **FSt** (fans disabling temperature) and **FAd** (fans differential).

**NOTE**: during defrost with electrical heaters, the compressor is OFF but the fans work as if the compressor was still ON, unless they have been disabled during defrost (see parameter **dFd**)

When evaporator fans have been enabled during defrost (**dFd = On**) and regulate on evaporator probe Pb2 in temperature control mode; when the latter go into "E2" error during defrost, the fans must always be ON irrespective of the values set by the duty-cycle.



### 5.3.5.5 - Fan function without probe

If parameter **H42 = n** (probe Pb2 absent), depending on the value of FCO and compressor status, fans could have these states: "On", "Off", "Duty Cycle Day" and "Duty Cycle Night".

Parameter **FCO** determines evaporator fan function mode during the DAY phase and during the NIGHT phase.

An example of fan function based on the value set for **FCO** is provided below.

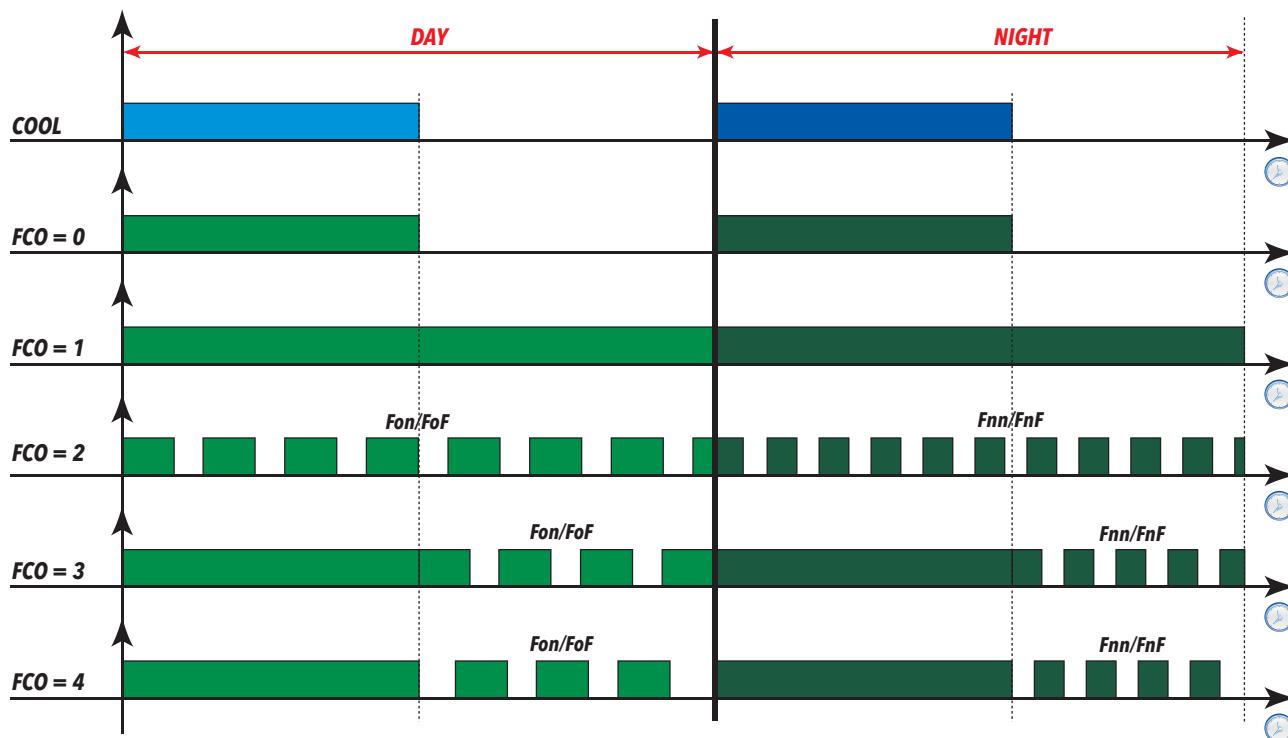

### 5.3.5.6 - Fan function during dripping

If parameter **dt**  $\neq 0$  (coil drainage time), the fans will stay OFF for the time set in this parameter.

See "**Defrost with electrical heaters**".

Note that if **Fdt** (fan delay time) is greater than **dt** (coil drainage time) the fans stay OFF for the time set in **Fdt** rather than **dt** (e.g. whichever timing is longer will be applied).

### 5.3.5.7 - Post-ventilation

Parameter **FdC** delays the switching off of the fans after the compressor has stopped (increasing efficiency of the system by making better use of inertia). Post-ventilation must be active with any FCO value and even when a probe has not been configured.

If **FdC = 0** the function is disabled.

 **NOTE:** Post-ventilation does not have priority over the delay set by parameter **dcd**.

### User parameters

The parameters that manage the fan regulator are:

Label	Description
FPt	Characterizes parameter "FSt" that can be expressed as an absolute value or in relation to the setpoint.
FSt	Evaporator fans disabling temperature
Fdt	Evaporator fans delay after defrost cycle
dFd	Evaporator fans disabling during defrost time
FCO	Evaporator fans operating mode
FAd	Evaporator fans activation differential
dt	Coil drainage time
FdC	Delay switching off evaporator fans after disabling the compressor.
Fon	Evaporator fans ON time in duty cycle day mode
FoF	Evaporator fans OFF time in duty cycle day mode
Fnn	Evaporator fans ON time in duty cycle night mode
FnF	Evaporator fans OFF time in duty cycle night mode
ESF	Night mode activation (Energy saving)





## 5.3.6 - RTC

### 5.3.6.1 - Weekdays/Weekends-Public Holidays

The controller can manage up to two weekend days/public holidays. These can be selected using parameters **Fd1** and **Fd2**.

For example:

 **EXAMPLE 1:** Let's say you want to set just one public holiday, a Monday for example. You need to set: **Fd1 = 1** (Monday), **Fd2 = 7** (disabled)

 **EXAMPLE 2:** Let's say you want to set a weekend day and a public holiday, a Wednesday and Sunday for example. You need to set: **Fd1 = 3** (Wednesday), **Fd2 = 0** (Sunday) or you could set: **Fd1 = 0** (Sunday), **Fd2 = 3** (Wednesday)

### 5.3.6.2 - Time-band defrost

The controller can manage up to 6 daily defrosts with two setpoints: one that applies to weekdays and another specific one for public holidays/weekends.

In addition to start defrost times, you can decide to use an identical end of defrost setpoint and time-out for all defrosts, or set specific values for each event.

When you set **Edt = 0**, each band will use the same end of defrost setpoint **ds1** (and **ds2**) and the same time-out **de1** (and **de2**).

When you set **Edt = 1**, you can define a specific setpoint **ds1** and time-out **de1** for each event.

This lets you schedule longer and/or more intense defrosts when the sales outlet is closed (when there is a lower heat demand on the counters). This mode is recommended for systems with single evaporator defrosting.

For double evaporator defrosting, all defrosts use the same **ds2** and **de2** and they cannot be customized.

### 5.3.6.3 - Periodical defrost

In some counters, all you have to do is run a defrost cycle every two/three/... days. This can be done using the set of parameters for periodical defrosting, where the activation time to be repeated every x days can be set.

### 5.3.6.4 - Events

The controller can manage two specific events, one applicable to all weekdays and one applicable to all weekends/public holidays.

These events have a start time and a duration. A standard example is the period a sales outlet is closed when, using events, lights can be automatically switched off, screens closed, the setpoint increased and other energy-saving functions implemented.

This is done by specifying the time the sales outlets closes, whereas the event duration is simply the same as the time it remains closed.

Every event can run one of the following functions:

- Null (function disabled).
- Energy-saving activation (\*).
- Activation Energy-Saving (\*) and light OFF.
- Energy-Saving Activation (\*), light OFF and activation of AUX outlet (e.g. to close curtains).
- Activation of device stand-by.

(\*) for Energy-Saving associated functions, see the specific section.



## 5.3.7 - ENERGY SAVING

The Energy Saving mode (sometimes called Night function) lets you activate a series of functions to reduce energy consumption when the outlet is closed.

- Modifies the average weight of the virtual probe/switching of regulation probe.
- Increases setpoint (reduced setpoint).
- Modifies regulation differential.
- Modulation of evaporator fans with setpoint satisfied.
- Reduction of power delivered by heaters (anti-condensation).

The Energy-Saving mode can be activated from:

- Digital input (when configured appropriately).
- RTC events.
- Remote command (from supervisor and/or via LAN).
- Hotkey.

The light and screen output (AUX) can be managed by configuring the following:

- RTC events (see RTC section).
- Dedicated digital input.
- Hotkey.
- Remote command (from supervisor and/or via LAN).

For the "reduced setpoint", "evaporator fans" and "frame heaters", see the relative sections.

### 5.3.7.1 - Virtual probe/ probe change

As well as regulating the various values coming from individual probes, the controller can also regulate on the basis of a weighted average of the value read by two probes; this is done via the so-called virtual probe.

- Virtual probe in Day mode:

$$\text{Virtual probe} = \frac{(\text{probe 1}) * \mathbf{H72} + (\text{probe 2}) * (100 - \mathbf{H72})}{100}$$

- Virtual probe in Energy Saving mode (Night):

$$\text{Virtual probe} = \frac{(\text{probe 1}) * \mathbf{H73} + (\text{probe 2}) * (100 - \mathbf{H73})}{100}$$

In the formula, **probe 1** is selected from parameter **H70**, and **probe 2** from parameter **H71**.

The switch between DAY and NIGHT mode in the regulation probe can be configured by setting **H72=100** and **H73= 0**:

- Virtual probe in Day mode:

$$\text{Virtual probe} = \text{probe 1}$$

Virtual probe in Energy saving mode (Night):

$$\text{Virtual probe} = \text{probe 2.}$$



### 5.3.8 - DEEP COOLING CYCLE (DCC)

#### Description

This regulator assures that the compressor regulates on the basis of setpoint **dCS**, with a differential equal to the value set in parameter **diF**. When the **DCC** (Deep Cooling Cycle) function activates, the interval between defrosts is cleared and defrosts are disabled.

**DCC** is stopped by setting parameter **tdc**≠0, or on reaching setpoint **dCS** if **tdc = 0**.

On exiting a **DCC**, and after a time that can be set in parameter **dcc**, a defrost is forced and counts start again for the interval between defrosts (value set by parameter **dit**). If **dcc=0**, the defrost starts at the end of **DCC**.

During the **DCC** cycle, temperature alarms are disabled.

Normal temperature control management is restored at the end of the **DCC** cycle when the temperature read by **rP1** returns to the value set in the regulation setpoint **SEt**.

#### Operating conditions

The Deep Cooling Cycle is reactivated via Digital Input or by hotkey when configured appropriately.

In the event of a probe error and/or power failure, the Deep Cooling Cycle is stopped and standard controller function restored.

If parameters **dCS**, **tdc** and **dcc** are modified, the Deep Cooling Cycle is recalculated with the new values set.

 **NOTE:** After a deep cooling cycle, before a new cycle can be started, the time set in **dcc** must elapse.

The control diagram is as follows:

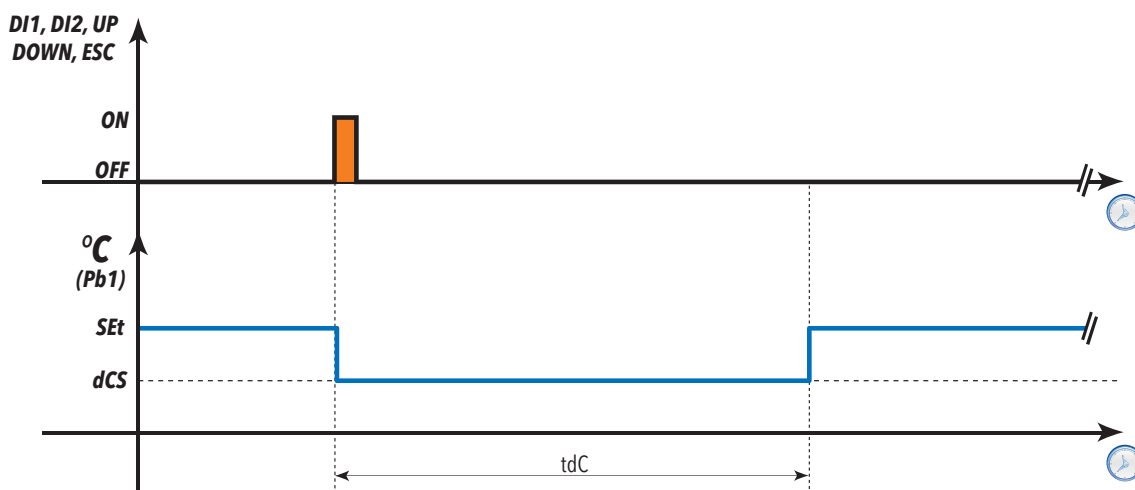

#### User parameters

The parameters that manage the fan regulator are:

Label	Description
dCS	Deep cooling cycle setpoint
tdc	Duration of deep cooling cycle
dcc	Delay before defrost after a deep cooling cycle.

### 5.3.9 - PREHEATING

When the preheating output is active, the following occur:

- The compressor output will be forced OFF.
- The compressor icon will (❄️) start to blink.

Preheating only effects defrosting in applications needing the compressor (**dtY**= 1 and **dtY**= 2).





## 5.3.10 - PRESSURE SWITCH

### Description

This regulator performs diagnostic operations over a digital input activated by assigning the value  $\pm 10$  (General pressure switch),  $\pm 11$  (Low pressure switch) or  $\pm 12$  (High pressure switch) to one of the parameters **H11 ...H18**.

If a pressure switch input is activated, power to the compressor is immediately cut off, the relative alarm LED lights up to provide a visual warning and a folder known as either **nPA** (general pressure switch), **LPA** (low pressure switch) or **HPA** (high pressure switch), depending on the type of pressure switch, is displayed in the alarms folder **ALr**. The folder contains the label with the number of pressure switch activations (up to the maximum value set in parameter **PEn**).

If the number of activations exceeds the maximum number defined by parameter **PEn** within a time less than the value of **PEI**, the following conditions occur:

- the compressor, fans and defrost are disabled
- in the alarms folder **AL** the label **PA** (pressure alarm) is displayed in place of folder **nPA, LPA or HPA**
- the label **PA** (general pressure switch), **PAL** (low pressure switch) or **PAH** (high pressure switch) is shown on the display
- the alarm relay comes on (if configured)

**! IMPORTANT:** 1) If the number of activations exceeds the number set in **PEn** within the time limit **PEI**, the alarm is automatically reset.

2) the input must be:

- self-closing if not used and the input is activated normally closed
- open if not used and activated normally open
- de-activated by the digital input configuration parameter.

**N.B.:** 1) Once the controller is in alarm state, it must be powered off then on, or RESET by activating function **rPA** in the functions folder **FPr**.

2) If parameter **PEn = 0**, the function is disabled and alarms and counters are also disabled.

3) the pressure switch alarm is not stored in EEPROM

4) During the pressure switch activation period the defrost interval count runs as normal.

### Operating conditions

The number of pressure switch errors is counted using a FIFO method. The time interval **PEI** is divided into 32 parts; the counter is incremented by one unit if there are one or more activations during one part of the entire interval **PEI**.

Two operating examples are given below: In both cases, suppose that **PEI = 32'** (equal to  $32'/32 = 1$  minute) and **PEn = 7**.

#### Example 1: ALARM SIGNALLED.

The interval for storing activations is 1 minute: all activations within that minute are counted as a single activation and the alarm (if any) is activated when the sampling interval has elapsed. In this example the pressure switch alarm is signalled because there have been 7 activations during the 32' time window.

#### Example 2: ALARM NOT SIGNALLED.

In this example the alarm is not activated because during the 32' time window the number of activations set in parameter **PEn** was not reached. In practice the time window is a rolling window and all activations that are outside of it are deleted: the reference point is the last activation and the time **PEI** is subtracted from that point to establish how many activations are included in the count.

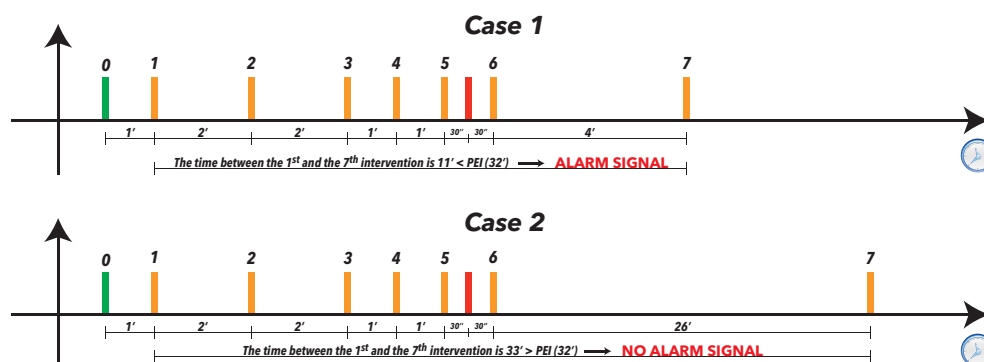

### User parameters

The parameters that manage the pressure switch regulator are:

Label	Description
PEn	number of errors allowed per general/low/high pressure switch input
PEI	General/low/high pressure switch error count interval (in 32 parts)



### 5.3.11 - AUXILIARY OUTPUT (AUX/LIGHT)

#### Description

If one of the parameters **H21...H27** is configured as **H2x=5**, the relay is commanded as AUX and, when the key associated to **H31...34** is pressed (which must be configured as **H3x=3**), the relay activates if it was previously off, and vice versa.

The on/off state is saved in non-volatile memory hence when power returns after a blackout, the device will restart in the state that was active prior to the blackout.

If one of the parameters **H11...H12** is configured as **H1x=3**, the AUX relay is commanded from digital input; in this case, the relay will mirror the state of the input. In this case, on/off state is not saved in non-volatile memory.



**CAUTION:** the meaning of the D.I. must always remain the same: for example, if the relay is activated by D.I. and switched off by key, when the D.I. is reset to the starting position, the relay does not change state (since it was already de-energised by key). With the instrument OFF, if set accordingly, only the digital input (D.I.) and the associated key can change the state of the output.

#### Operating conditions

The regulator is activated by:

- Key
- Function
- Digital Input
- Energy-saving activation

if configured accordingly.

The regulator is not active when:

Condition	AUX output state	NOTES
during start-up	OFF	
during standby	state depends on parameter <b>H08</b>	

The control diagram is as follows:

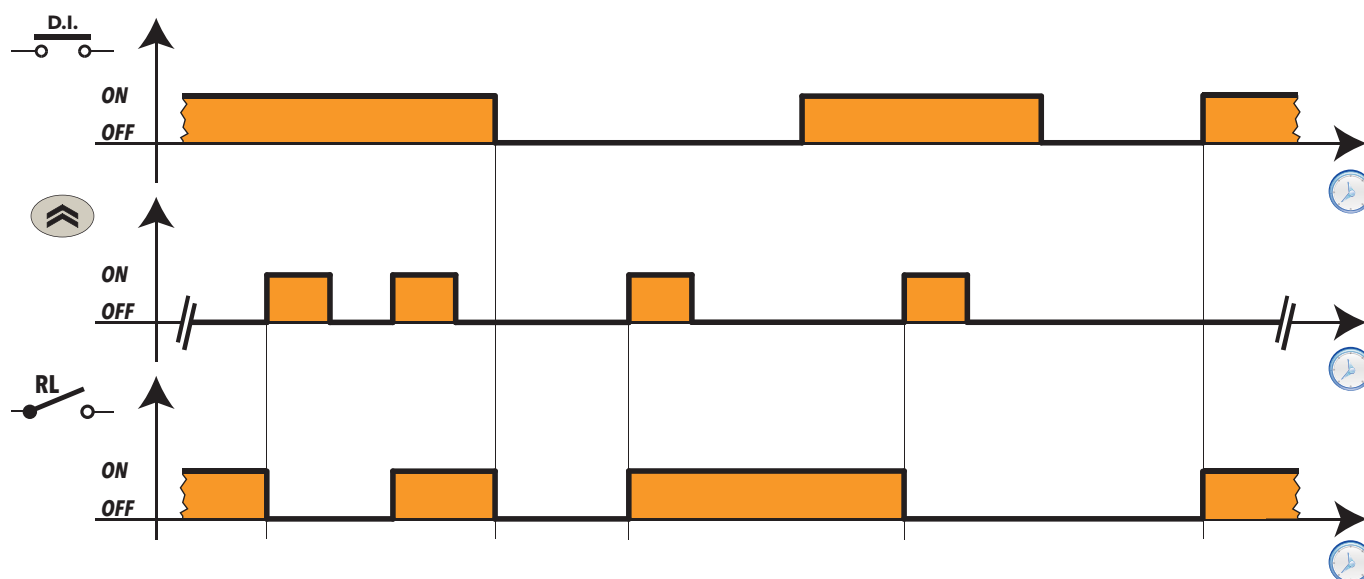

#### User parameters

The parameters that manage the auxiliary (AUX) output regulator are:

Label	Description
H11...H18	Configuration of digital input 1...8/Polarity
H21...H27	Configuration of digital output 1.....7
H31...H34	Configuration key 1,2,3 and 4



### 5.3.12 - DOOR/EXTERNAL ALARM MANAGEMENT

The door switch input is associated to an appropriately configured digital input (**H1x = ±4**).

By controlling the opening of the door, it is possible to deactivate the compressor output and/or the fans.

It is also possible to associate a deactivation delay to the compressor output by means of parameter **dCO**.

If the door is opened during a defrost cycle, the cycle is not shut down.

The following values can be assigned to the various parameters:

**dod**: Door switch switches off utilities by DI command.

- **0** = function disabled
- **1** = disables FANS
- **2** = disables Compressor (COMP)
- **3** = disables Compressor (COMP) and fans (FAN)

The intention is that any safety timings (e.g. delay switching on compressor, etc.) will still be respected.

**EAL**: blocks compressor regulators, defrosting and fans if the digital input (configured as an external alarm) is activated.

- **0** = no resource blocked
- **1** = compressor and defrost blocked
- **2** = compressor, defrost and fans blocked

**dOA**: defines what to activate/disable on the activation/deactivation of the digital input. Valid only if **PEA** ≠ 0.

- **0** = activates compressor (COMP)
- **1** = activates the fans (FAN)
- **2** = activates the compressor (COMP) and fans (FAN)
- **3** = disables the compressor (COMP)
- **4** = disables the fans (FAN)
- **5** = disables the compressor (COMP) and fans (FAN)

**PEA**: Defines whether the door switch or external alarm should be linked to parameter **dOA** in the following mode:

- **0** = function disabled
- **1** = function linked to door switch
- **2** = function linked to external alarm
- **3** = function linked to door switch and external alarm



**dCO**: Delay activating/switching off compressor (0 ... 250 min).

**dFO**: Delay activating/switching off evaporator fans (0 ... 250 min).

**tdO**: Door open alarm exclusion time (0 ... 250 min). The door open alarm is activated if the door remains open for longer than the time set in this parameter.

The way parameters **dCO** and **dFO** act depends on how parameter **dOA** is configured. To better understand the meaning of these parameters, see the figures below.

Graphs explaining fan function based on the value of **dOA** are provided below. In the graphs you will see:

	Door
	Evaporator Fans
	Compressor

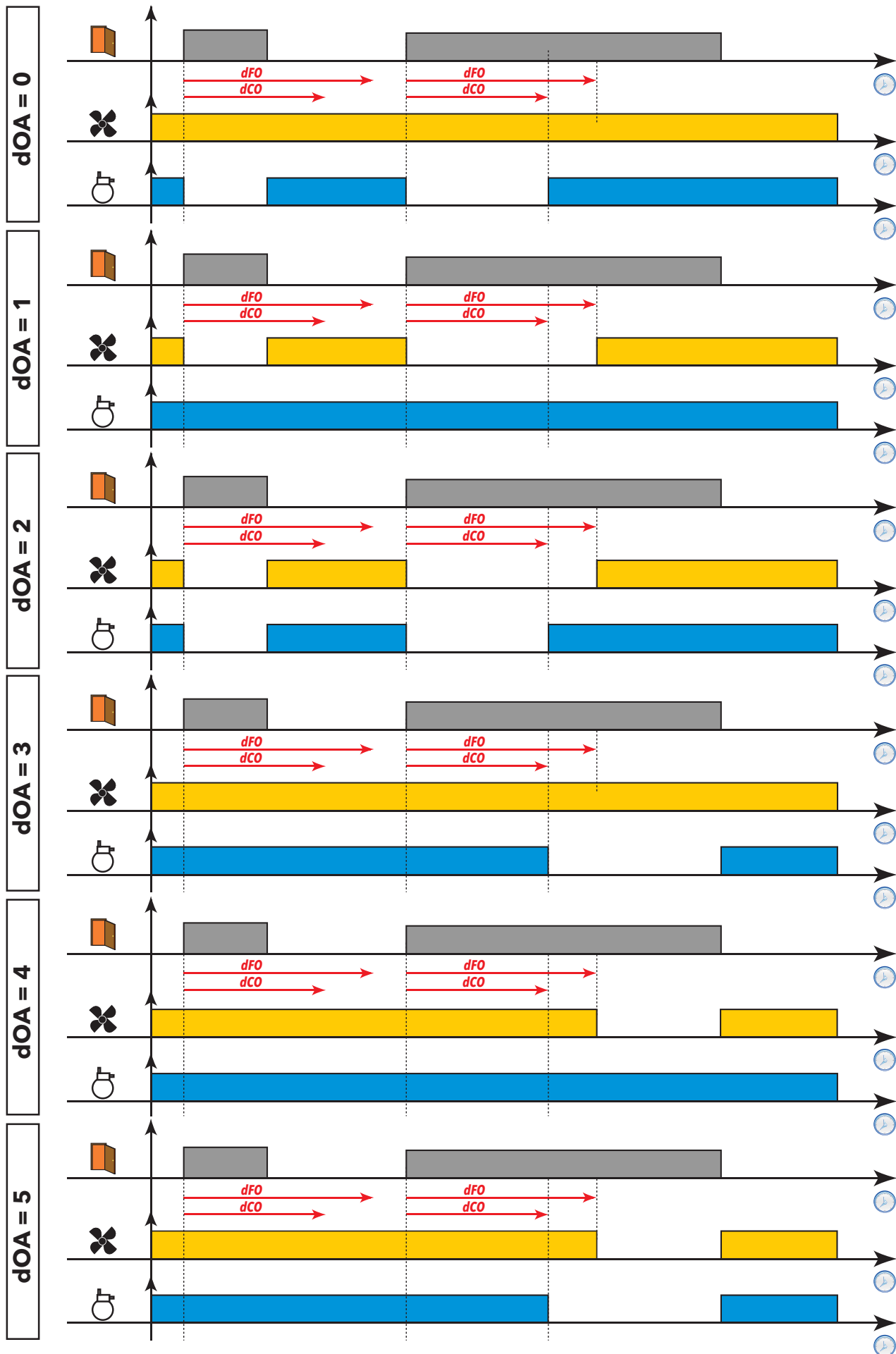



### 5.3.13 - FRAME HEATER

The controller is fitted with a regulator for frame heaters.  
Regulation can occur by:

- Fixed value.
- Glass door probe.
- Glass door probe with dew point from remote.

The output can be:

- Open collector: to pilot an external SSR module.
- 4...20mA/0...10V: to pilot a dedicated model.

#### 5.3.13.1 - Connection Examples

Some connection examples are provided below:

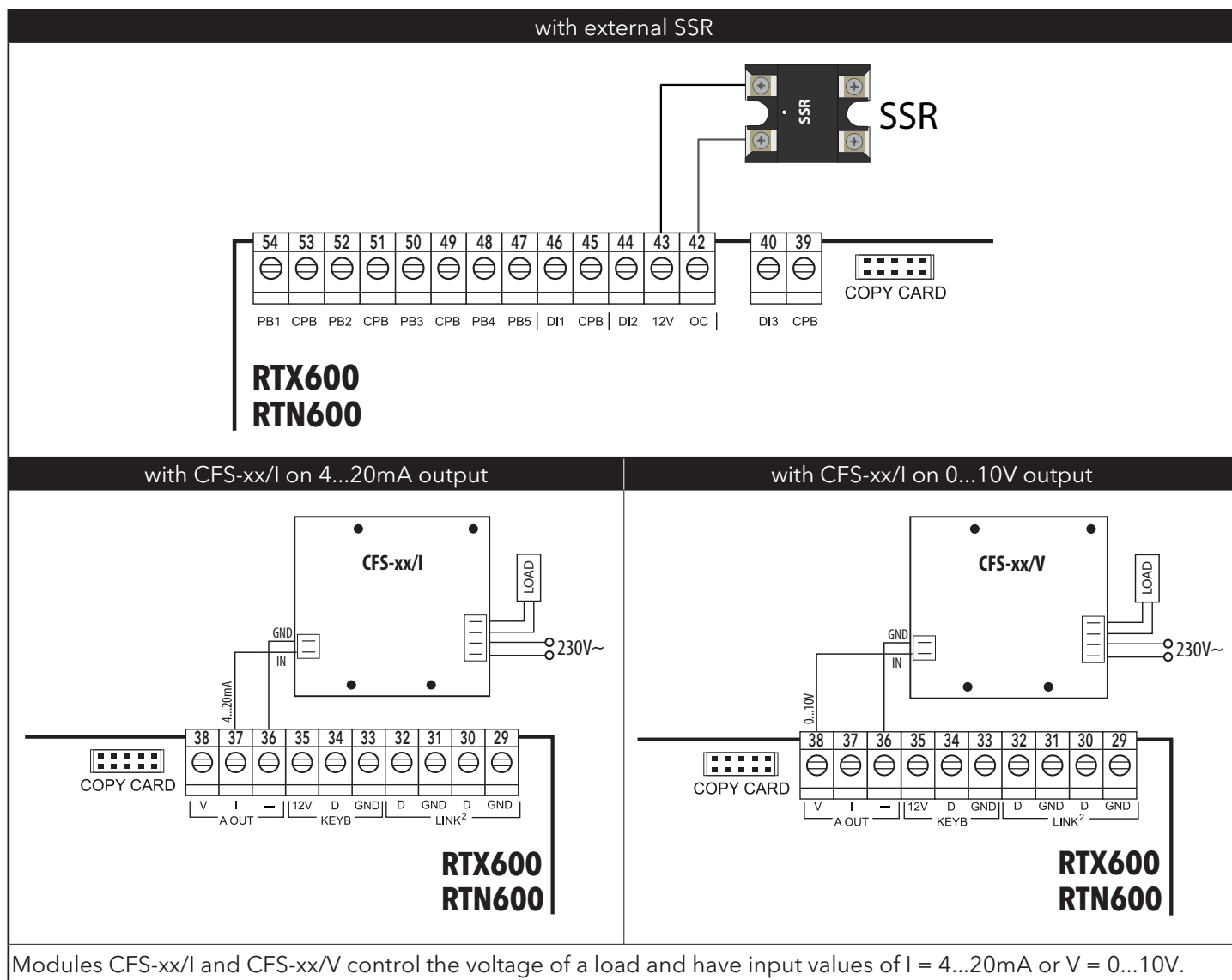



### 5.3.13.2 - Fixed value regulation

Fixed value regulation occurs when parameter **FH = dc** and the following regulation percentages are set:

- Parameter **FH4**: Day.
- Parameter **FH5**: Night (Energy Saving - Night).
- Parameter **FH6**: Defrost (during Day and Night).

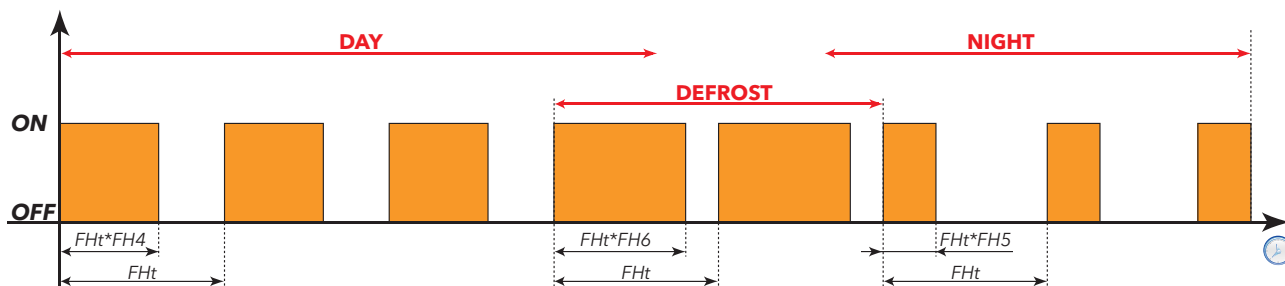

If you use the open collector output (or relay, although we don't recommend the latter), regulation occurs via modulation where parameter **FHt** sets the modulation period.

The analogue output can also be used (4...20mA/0...10V).

In this case, the value of the output will stay at the regulation percentage for each phase.

### 5.3.13.3 - Glass door probe regulation

Regulation by glass door probe occurs by selecting the required probe via parameter **FH**.

(**diS** = disabled; **dc** = Duty Cycle; **Pb1...Pb5** = probe Pb1...Pb5; **Pbi** = virtual probe).

The value of the output depends on the value of the probe, as indicated in the graph:

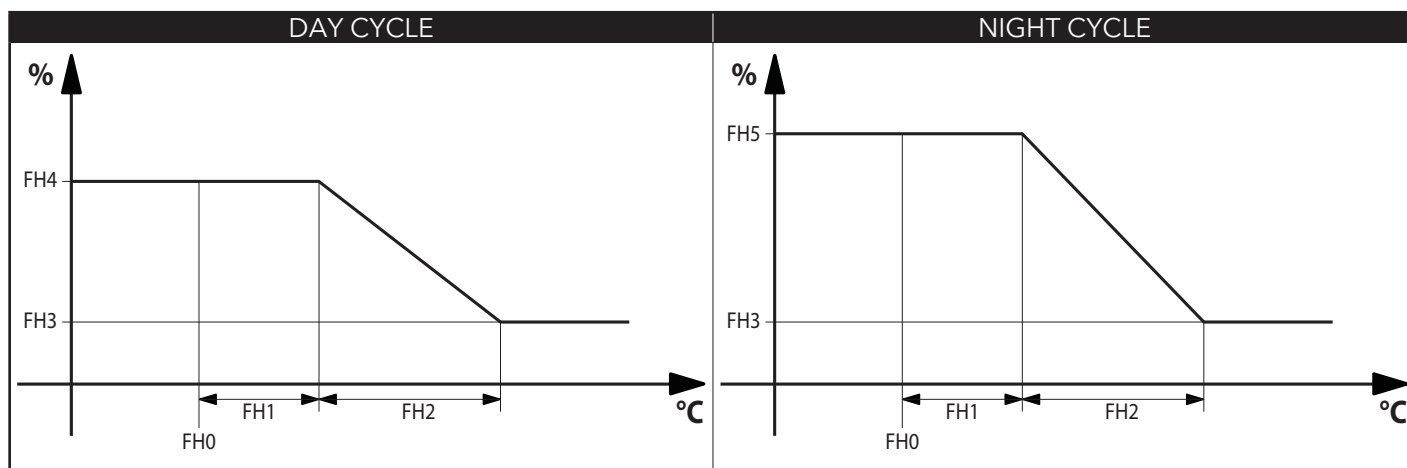

During the defrost stage, the output will be set to the fixed value shown in parameter **FH6**.

In the event of a probe error, the output will be put to the maximum value (**FH4** for day, **FH5** at night - Energy Saving).

The regulator can modulate the analogue output (4...20mA/0...10V), or modulate the open collector output (in this case, the period is given by parameter **FHt**).

### 5.3.13.4 - Regulation based on glass door probe with dew point from remote.

Regulation is similar to the previous section, the only difference being relative to the setpoint value **FH0** which is modified from remote (remote dew point) and managed by the supervisor via serial commands.

On starting up, the regulator loads the setpoint value indicated in parameter **FH0**. The regulation setpoint value can be updated from remote (value in volatile memory).



**N.B.:** Updating from remote must take place within 60 seconds otherwise the regulator will reload the value in parameter **FH0**.



## User parameters

The parameters that manage the Standby regulator are:

Label	Description
FH	Selects which probe will be used by frame heaters.
FHt	Frame heater running time. <b>N.B.</b> = only used when OC output is used with SSR relay.
FH0	Configuration of relative setpoint for frame heater (only if <b>FH≠diS</b> and <b>FH≠dc</b> ).
FH1	Configuration of relative offset for frame heater (only if <b>FH≠diS</b> and <b>FH≠dc</b> ).
FH2	Configuration of relative band for frame heater (only if <b>FH≠diS</b> and <b>FH≠dc</b> ).
FH3	Configuration of minimum percentage for frame heater (only if <b>FH≠diS</b> e <b>FH≠dc</b> ).
FH4	Sets maximum percentage for day Duty Cycle.
FH5	Sets maximum percentage for night Duty Cycle.
FH6	Sets percentage during defrost.

### 5.3.14 - GENERAL INPUT

The general input does carry out any function locally in the controller.

Its function is to monitor from remote the state of the input that a device/specific sensor will be associated to.

#### EXAMPLE:

The general input can be connected to the output of an ice sensor to monitor if the chiller cabinet (e.g. vegetable counter) is blocked.

In this case, during defrosting, since the water cannot flow anywhere, it collects and turns into ice which gradually obstructs the evaporator. Using an ice sensor, you can monitor if the gap between the evaporator and base of the cabinet is blocked by ice.

### 5.3.15 - STANDBY

#### Operating conditions

The Standby regulator can be activated by digital input (if configured) or by key (if programmed).

**With the device OFF the display shows "OFF" and all regulators are blocked including alarms.**

When the device is switched on via a key or an appropriately configured digital input, regular operation commences, the same as from power-on. After power-on, the temperature alarm is excluded for a time set in parameter **PAO**, and the delay set in parameter **Odo** is activated.

Each time that the device is switched off, all cycle times are reset.

The on/off state is saved in non-volatile memory hence when power returns after a blackout, the device will restart in the state that was active prior to the blackout.

The output from standby is linked to the delay set in parameter **Odo**.



**N.B.:** When the device is switched off, all relays are de-energized except for Aux: key/aux input/light/door switch are active.

## User parameters

The parameters that manage the Standby regulator are:

Label	Description
PAO	Alarm disabling after power-on
Odo	Delay output enabling from power-on
OAO	High and low temperature alarms disabling time after door closing

## 6 - PARAMETERS TABLE



### 6.1 - PARAMETERS TABLE

#### 6.1.1 - "USER" MENU PARAMETERS TABLE

PAR.	DESCRIPTION	UM	RANGE	AP1	AP2	AP3	AP4	AP5	AP6	AP7	AP8
SP1	Temperature control SEtpoint	°C/°F	-58.0...302	3.0	-22.0	-22.0	-22.0	-22.0	-22.0	-22.0	-22.0
SP2	Temperature control SEtpoint second thermostat (only if <b>rE</b> ≠0).	°C/°F	-58.0...302					-22.0			
<b>COMPRESSOR (CP)</b>											
rE	Sets the type of regulation to be implemented.	num	0 ... 4					2			
rP1	Sets regulation probe 1.	num	dis/Pb1 ... Pb5 Pbi/LP	Pbi	Pb1	Pb1	Pb1	Pb1	Pb1	Pb1	Pb1
rP2	Sets control probe of thermostat 2 (only if <b>rE</b> ≠0).	num	dis Pb1 ... Pb5					Pb2			
dF1	Activation differential (absolute or relative). <b>NB: dF1</b> ≠ 0.	°C/°F	-58.0...302	4.0	4.0	4.0	4.0	4.0	4.0	4.0	4.0
dF2	Thermostat 2 activation differential (absolute or relative) (only if <b>rE</b> ≠0). <b>NB: dF2</b> ≠ 0.	°C/°F	-58.0...302					4.0			
HS1	Maximum value assignable to setpoint SP1.	°C/°F	LS1...302	20.0	0.0	0.0	20.0	0.0	0.0	0.0	0.0
LS1	Minimum value assignable to setpoint SP1.	°C/°F	-58.0...HS1	-10.0	-35.0	-35.0	-10.0	-35.0	-35.0	-35.0	-35.0
HS2	Maximum value attributable to setpoint SP2 (only if <b>rE</b> ≠0).	°C/°F	LS2...302					0.0			
LS2	Minimum value attributable to setpoint SP2 (only if <b>rE</b> ≠0).	°C/°F	-58.0...HS2					-35.0			
Cit	Compressor minimum running time before switching off. If <b>Cit</b> = 0 it is not active.	min	0 ... 250	5	5	5	5	5	5	5	5
CAt	Compressor maximum running time before switching off. If <b>CAt</b> = 0 it is not active.	min	0 ... 250	0	0	0	0	0	0	0	0
Ont	Controller switch-on time in the event of faulty probe.	min	0 ... 250	3	3	3	3	3	3	3	3
OFt	Controller switch-off time in the event of a faulty probe.	min	0 ... 250	3	3	3	3	3	3	3	3
dOn	Delay time between switch-ons; the delay time indicated must elapse between two consecutive compressor switch-ons.	min	0 ... 250	0	0	0	0	0	0	0	0
dOF	Delay time after switch off: the delay time indicated must elapse between deactivation of the compressor relay and the next switch-on.	min	0 ... 250	2	2	2	2	2	2	2	2
dbi	Delay time between switch-ons; the delay time indicated must elapse between two consecutive compressor switch-ons.	min	0 ... 250	0	0	0	0	0	0	0	0
Od0	Delay to activate outputs from switch on or after power failure.	min	0 ... 250	0	0	0	0	0	0	0	0
<b>DEFROST (dEF)</b>											
dP1	Selects which probe will be used by defrost 1.	num	dis/Pb1 ... Pb5, Pbi, LP	Pb3	Pb3	Pb3	Pb3	Pb3	Pb3	Pb3	Pb3
dtY	defrost type. Type of defrost.	num	0 ... 4	4	4	4	4	4	0	2	4
dit	Interval between the start of two consecutive defrost cycles.	hours	0 ... 250	0	0	0	0	0	0	0	0
dCt	Selects the count mode for the defrost interval.	num	0 ... 5	4	4	4	4	4	4	4	4
dE1	Defrost time for evaporator 1; determines maximum defrost duration.	min	1 ... 250	30	30	30	30	30	30	30	30
dS1	Defrost 1 end temperature (determined by the 1st evaporator probe).	°C/°F	-58.0...302	7.0	7.0	7.0	7.0	7.0	12.0	12.0	7.0
dSS	Start defrost temperature threshold (only if dCt = 5 - temperature).	°C/°F	-58.0...302	-5.0	-30.0	-30.0	-5.0	-30.0	-30.0	-30.0	-30.0
dPO	Determines if device must commence defrost when switched on.	flag	no/yES	no	no	no	no	no	no	no	no
tcd	Minimum time that must elapse with the compressor ON or OFF before defrost is activated.	min	-60 ... 60							3	
ndE	Defrost duration in minutes (only if set "for hot gas").	min	0 ... 250							15	
PdC	Hot gas extraction time at defrost end.	min	0 ... 250							0	
tPd	Minimum pump down time that must elapse before defrost starts.	min	0 ... 255							0	
dPH	Periodic defrost start time. <b>0 ... 23</b> = start hour; <b>24</b> = disabled.	hours	0 ... 24	24	24	24	24	24	24	24	24
dPn	Periodic defrost start minutes.	min	0 ... 59	0	0	0	0	0	0	0	0
dPd	Interval between one defrost and next (periodic function).	days	1 ... 7	1	1	1	1	1	1	1	1
Fd1	1st holiday. <b>0 ... 6</b> = start day; <b>7</b> = disabled.	days	0 ... 7	0	0	0	0	0	0	0	0
Fd2	2nd holiday. <b>0 ... 6</b> = start day; <b>7</b> = disabled.	days	0 ... 7	7	7	7	7	7	7	7	7
d1H	1st workday defrost start hour. <b>0 ... 23</b> = start hour; <b>24</b> = disabled.	hours	0 ... 24	7	0	0	7	0	7	0	0
d1n	1st workday defrost start minutes.	min	0 ... 59	0	0	0	0	0	0	0	0
d2H	2nd workday defrost start hour. <b>d1H ... 23</b> = start hour; <b>24</b> = disabled.	hours	0 ... 24	21	6	6	21	6	21	6	6
d2n	2nd workday defrost start minutes.	min	0 ... 59	0	0	0	0	0	0	0	0
d3H	3rd workday defrost start hour. <b>d2H 23</b> = start hour; <b>24</b> = disabled.	hours	0 ... 24	24	12	12	24	12	24	12	12
d3n	3rd workday defrost start minutes.	min	0 ... 59	0	0	0	0	0	0	0	0
d4H	4th workday defrost start hour. <b>d3H ... 23</b> = start hour; <b>24</b> = disabled.	hours	0 ... 24	24	18	18	24	18	24	18	18
d4n	4th workday defrost start minutes.	min	0 ... 59	0	0	0	0	0	0	0	0
d5H	5th workday defrost start hour. <b>d4H ... 23</b> = start hour; <b>24</b> = disabled.	hours	0 ... 24	24	24	24	24	24	24	24	24
d5n	5th workday defrost start minutes.	min	0 ... 59	0	0	0	0	0	0	0	0
d6H	6th workday defrost start hour. <b>d5H ... 23</b> = start hour; <b>24</b> = disabled.	hours	0 ... 24	24	24	24	24	24	24	24	24





PAR.	DESCRIPTION	UM	RANGE	AP1	AP2	AP3	AP4	AP5	AP6	AP7	AP8
<b>d6n</b>	6th workday defrost start minutes.	min	0 ... 59	0	0	0	0	0	0	0	0
<b>F1H</b>	1st holiday defrost start hour. <b>0 ... 23</b> = start hour; <b>24</b> = disabled.	hours	0 ... 24	12	0	0	12	0	12	0	0
<b>F1n</b>	1st holiday defrost start minutes.	min	0 ... 59	0	0	0	0	0	0	0	0
<b>F2H</b>	2nd holiday defrost start hour. <b>F1H ... 23</b> = start hour; <b>24</b> = disabled.	hours	0 ... 24	23	6	6	23	6	23	6	6
<b>F2n</b>	2nd holiday defrost start minutes.	min	0 ... 59	0	0	0	0	0	0	0	0
<b>F3H</b>	3rd holiday defrost start hour. <b>F2H ... 23</b> = start hour; <b>24</b> = disabled.	hours	0 ... 24	24	12	12	24	12	24	12	12
<b>F3n</b>	3rd holiday defrost start minutes.	min	0 ... 59	0	0	0	0	0	0	0	0
<b>F4H</b>	4th holiday defrost start hour. <b>F3H ... 23</b> = start hour; <b>24</b> = disabled.	hours	0 ... 24	24	18	18	24	18	24	18	18
<b>F4n</b>	4th holiday defrost start minutes.	min	0 ... 59	0	0	0	0	0	0	0	0
<b>F5H</b>	4th holiday defrost start hour. <b>F4H ... 23</b> = start hour; <b>24</b> = disabled.	hours	0 ... 24	24	24	24	24	24	24	24	24
<b>F5n</b>	5th holiday defrost start minutes.	min	0 ... 59	0	0	0	0	0	0	0	0
<b>F6H</b>	6th holiday defrost start hour. <b>F5H ... 23</b> = start hour; <b>24</b> = disabled.	hours	0 ... 24	24	24	24	24	24	24	24	24
<b>F6n</b>	6th holiday defrost start minutes.	min	0 ... 59	0	0	0	0	0	0	0	0
<b>FANS (FAn)</b>											
<b>FP1</b>	Selects which probe will be used by evaporator fans in normal operation.	num	dis/Pb1 ... Pb5, Pbi, LP	diS	diS	Pb3	Pb3	Pb3	Pb3	Pb3	diS
<b>FSt</b>	Fans disabling temperature. The value is positive or negative. (only if <b>FP1</b> ≠ diS).	°C/°F	-58.0...302	0.0	0.0	0.0	0.0	0.0	0.0	0.0	0.0
<b>FAd</b>	Fan activation differential (only if <b>FP1</b> ≠ diS).	°C/°F	0.1 ... 25.0	0.1	0.1	4.0	4.0	4.0	4.0	4.0	0.1
<b>Fdt</b>	Fans activation delay after a defrost cycle.	min	0 ... 250						1		
<b>dt</b>	drainage time. Coil drainage time.	min	0 ... 250	0	5	5	5	5	5	3	0
<b>dFd</b>	Evaporator fans operating mode during defrost.	flag	OFF/On			On	On	On	On	OFF	
<b>FCO</b>	Evaporator fans operating mode.	num	0 ... 4			1	1	1	0	1	
<b>FdC</b>	Evaporator fans switch-off delay after compressor disabled.	min	0 ... 250						5		
<b>FOn</b>	Fan ON time in duty cycle day. Fans used in duty cycle mode; applies to <b>FCO = dc</b> and <b>FP1</b> is present.	min	0 ... 250		1	1	1	1	1	1	1
<b>FOF</b>	Fan OFF time in duty cycle day. Fans used in duty cycle mode; applies to <b>FCO = dc</b> and <b>FP1</b> is present.	min	0 ... 250		0	0	0	0	0	0	0
<b>Fnn</b>	Fan ON time in duty cycle night. Fans used in duty cycle mode; applies to <b>FCO = dc</b> and <b>FP1</b> is present.	min	0 ... 250		2	1	1	1	1	1	2
<b>FnF</b>	Fan OFF time in duty cycle night. Fans used in duty cycle mode; applies to <b>FCO = dc</b> and <b>FP1</b> is present.	min	0 ... 250		2	0	0	0	0	0	2
<b>ALARMS (AL)</b>											
<b>ra1</b>	Selects probe 1 which will be used for temperature alarms.	num	diS, Pb1 ... Pb5, Pbi	Pbi	Pb1	Pb1	Pb1	Pb1	Pb1	Pb1	Pb1
<b>ra2</b>	Selects probe 2 which will be used for temperature alarms. Same as <b>ra1</b> .	num	diS, Pb1 ... Pb5, Pbi					Pb2			
<b>Att</b>	Parameters <b>HAL</b> and <b>LAL</b> mode. <b>AbS</b> = absolute value; <b>reL</b> = relative value.	flag	AbS/reL	rEL	rEL	rEL	rEL	rEL	rEL	rEL	rEL
<b>Afd</b>	Alarm activation differential.	°C/°F	0.1 ... 25.0	4.0	4.0	4.0	4.0	4.0	4.0	4.0	4.0
<b>HA1</b>	Probe 1 maximum alarm.	°C/°F	LA1...302	5.0	5.0	5.0	5.0	5.0	5.0	5.0	5.0
<b>LA1</b>	Probe 1 minimum alarm.	°C/°F	-58.0...HA1	-5.0	-5.0	-5.0	-5.0	-5.0	-5.0	-5.0	-5.0
<b>HA2</b>	Probe 2 maximum alarm (only if <b>ra2</b> ≠ diS).	°C/°F	LA2...302					5.0			
<b>LA2</b>	Probe 2 minimum alarm (only if <b>ra2</b> ≠ diS).	°C/°F	-58.0...HA2					-5.0			
<b>PAO</b>	Alarm override time after device is switched on following a power failure.	hours	0 ... 10	3	3	3	3	3	3	3	3
<b>dAO</b>	Temperature alarm exclusion time after defrost.	min	0 ... 250	30	30	30	30	30	30	30	30
<b>OAo</b>	Alarm signal delay (low and high temperature) after the deactivation of the digital input (port closed).	hours	0 ... 10						10		
<b>tdo</b>	Delay in door open alarm activation.	min	0 ... 250						10		
<b>ta1</b>	Time delay for temperature alarm indication.	min	0 ... 250	0	0	0	0	0	0	0	0
<b>ta2</b>	Temperature alarm signal delay (only if <b>ra2</b> ≠ diS).	min	0 ... 250					0			
<b>dAt</b>	Alarm signaling end of defrost due to timeout. <b>no</b> = no; <b>yes</b> = yes.	flag	no/yES	no	no	no	no	no	no	no	no
<b>EAL</b>	Regulators blocked by external alarm.	num	0/1/2						0		
<b>tp</b>	All keys acknowledge an alarm. <b>no</b> = no; <b>yes</b> = yes.	flag	no/yES						no		
<b>LIGHTS &amp; DIGITAL INPUTS (Lit)</b>											
<b>dSd</b>	Enable light relay from door switch. <b>no</b> = no; <b>yES</b> = yes.	flag	no/yES						yES		
<b>dLt</b>	Light relay (room light) deactivation (switch-off) delay.	min	0 ... 250						0		
<b>OFL</b>	Light key always disables the light relay. <b>no</b> = no; <b>yES</b> = yes.	flag	no/yES						no		
<b>dOd</b>	Enable utility switch-off on activation of door switch.	num	0 ... 3						1		
<b>dOA</b>	Forced action of digital input (only if <b>PEA</b> ≠ 0):	num	0 ... 5						2		
<b>PEA</b>	Selection of a digital input with resource blocking/unblocking function.	num	0 ... 3						1		
<b>dCO</b>	Delay activating/deactivating compressor after request.	min	0 ... 250						5		
<b>dFO</b>	Delay activating/deactivating fans after request.	min	0 ... 250						5		



PAR.	DESCRIPTION	UM	RANGE	AP1	AP2	AP3	AP4	AP5	AP6	AP7	AP8
<b>ASb</b>	Activation by key of AUX or LIGHT input when the controller is in standby. <b>no</b> = no; <b>yES</b> = yes.	flag	no/yES						no		
<b>LINK<sup>2</sup> (Lin)</b>											
<b>L00</b>	Selects which probe to share.	num	diS, Pb1 ... Pb5, Pbi	diS	diS	diS	diS	diS		diS	diS
<b>L01</b>	Shares the displayed value with the LAN.	num	0/1/2	0	0	0	0	0		0	0
<b>L02</b>	Sends setpoint value to the LINK <sup>2</sup> network after it has been modified. <b>no</b> =no; <b>yES</b> =yes.	flag	no/yES	no	no	no	no	no		no	no
<b>L03</b>	Enables the defrost request to be sent to the LINK <sup>2</sup> network. <b>no</b> = no; <b>yES</b> = yes.	flag	no/yES	no	no	no	no	no		no	no
<b>L04</b>	Defrost end mode. <b>ind</b> = independent; <b>dEP</b> = dependent.	flag	ind/dEP	ind	ind	ind	ind	ind		ind	ind
<b>L05</b>	Enables synchronisation of the Standby command. <b>no</b> = no; <b>yES</b> = yes.	flag	no/yES	no	no	no	no	no		no	no
<b>L06</b>	Enables synchronisation of the lights command. <b>no</b> = no; <b>yES</b> = yes.	flag	no/yES	no	no	no	no	no		no	no
<b>L07</b>	Enables synchronisation of the Energy Saving command. <b>no</b> = no; <b>yES</b> = yes.	flag	no/yES	no	no	no	no	no		no	no
<b>L08</b>	Enables synchronisation of the AUX command. <b>no</b> = no; <b>yES</b> = yes.	flag	no/yES	no	no	no	no	no		no	no
<b>L10</b>	Sets the time delay to be set after the end of dependent defrosts.	min	0 ... 250	30	30	30	30	30		30	30
<b>PRESSURE SWITCH (PrE)</b>											
<b>PEn</b>	Number of errors allowed per pressure switch input. <b>0</b> = disabled.	num	0 ... 15	0	0	0	0	0	0	0	0
<b>PEi</b>	Pressure switch error count interval.	min	1 ... 250	1	1	1	1	1	1	1	1
<b>ENERGY SAVING (EnS)</b>											
<b>ESt</b>	Type of event activated by RTC.	num	0 ... 4	3	2	2	2	2		2	2
<b>ESF</b>	Night mode activation (energy saving) for fans ( <b>ESt</b> ≠ <b>0</b> and <b>ESt</b> ≠ <b>4</b> ).	flag	no/yES		yES	no	no	no	no	no	yES
<b>Cdt</b>	Door close time.	min*10	0 ... 255		0				0		30
<b>ESo</b>	Cumulative door opening time to disable Energy Saving mode.	num	0 ... 10		0				0		5
<b>OS1</b>	Setpoint offset 1.	°C/°F	-50.0...50.0	3.0	3.0	3.0	3.0	3.0	3.0	3.0	3.0
<b>OS2</b>	Offset setpoint 2 (only if <b>rE</b> ≠ <b>0</b> ).	°C/°F	-50.0...50.0					3.0			
<b>Od1</b>	Energy Saving Offset 1 glass door display cabinets.	°C/°F	-50.0...50.0		1.0				0.0		1.0
<b>dn1</b>	Activation differential 1 in energy saving mode.	°C/°F	-58.0...302	4.0	4.0	4.0	4.0	4.0	4.0	4.0	4.0
<b>dn2</b>	Activation 2 differential in energy saving mode (only if <b>rE</b> ≠ <b>0</b> ).	°C/°F	-58.0...302					4.0			
<b>EdH</b>	Start time hours weekday Energy Saving. <b>0 ... 23</b> = start hour; <b>24</b> = disabled.	hours	0 ... 24	21	21	21	21	21		21	21
<b>Edn</b>	Workday Energy Saving start minutes.	min	0 ... 59	0	0	0	0	0		0	0
<b>Edd</b>	Duration of workday Energy Saving.	hours	1 ... 72	10	10	10	10	10		10	10
<b>EFH</b>	Holiday Energy Saving start hour. <b>0 ... 23</b> = start hour; <b>24</b> = disabled.	hours	0 ... 24	0	0	0	0	0		0	0
<b>EFn</b>	Holiday Energy Saving start minutes.	min	0 ... 59	0	0	0	0	0		0	0
<b>EFd</b>	Duration of holiday Energy Saving.	hours	1 ... 72	24	24	24	24	24		24	24
<b>FRAME HEATER (FrH)</b>											
<b>FH</b>	Selects which probe will be used by the anti-sweat heaters (Frame Heater):	num	diS, dc, Pb1 ... Pb5, Pbi	dc	dc	dc	dc	dc		dc	Pb4
<b>FHt</b>	Frame heater running time.	sec*10	1 ... 2500	30	30	30	30	30		30	30
<b>FH0</b>	Sets setpoint for Frame Heater (only if <b>FH</b> ≠ <b>dis</b> and <b>FH</b> ≠ <b>dc</b> ).	°C/°F	-58.0...302	0.0	0.0	0.0	0.0	0.0		0.0	0.0
<b>FH1</b>	Sets offset for Frame Heater (only if <b>FH</b> ≠ <b>dis</b> and <b>FH</b> ≠ <b>dc</b> ).	°C/°F	0.0 ... 25.0	0.0	0.0	0.0	0.0	0.0		0.0	10.0
<b>FH2</b>	Sets band for Frame Heater (only if <b>FH</b> ≠ <b>dis</b> and <b>FH</b> ≠ <b>dc</b> ).	°C/°F	0.0 ... 25.0	0.0	0.0	0.0	0.0	0.0		0.0	10.0
<b>FH3</b>	Sets minimum percentage for Frame Heater (only if <b>FH</b> ≠ <b>dis</b> and <b>FH</b> ≠ <b>dc</b> ).	%	0 ... 100	0	0	0	0	0		0	20
<b>FH4</b>	Sets maximum percentage for day Duty Cycle.	%	0 ... 100	75	75	75	75	75		75	100
<b>FH5</b>	Sets maximum percentage for night Duty Cycle.	%	0 ... 100	50	50	50	50	50		50	80
<b>FH6</b>	Sets percentage during defrost.	%	0 ... 100	100	100	100	100	100		100	100
<b>COMMUNICATION (Add)</b>											
<b>PtS</b>	Select protocol ( <b>t</b> (0) = Televis; <b>d</b> (1) = ModBus).	flag	t/d	<b>t (Parameter not present in vectors)</b>							
<b>dEA</b>	Device address: indicates the device address to the management protocol.	num	0 ... 14	<b>0 (Parameter not present in vectors)</b>							
<b>FAA</b>	Family address: indicates the device family to the management protocol.	num	0 ... 14	<b>0 (Parameter not present in vectors)</b>							
<b>Adr</b>	Modbus protocol controller address (only if <b>PtS</b> = <b>d</b> ).	num	1 ... 250	<b>1 (Parameter not present in vectors)</b>							
<b>baU</b>	Baudrate selection ( <b>96</b> (0) = 9600; <b>192</b> (1) = 19200; <b>384</b> (2) = 38400).	num	96/192/384	<b>0 (Parameter not present in vectors)</b>							
<b>Pty</b>	Sets Modbus parity bit ( <b>n</b> = none; <b>E</b> = equal; <b>o</b> = unequal). (only if <b>PtS</b> = <b>d</b> )	num	n/E/o	<b>n (Parameter not present in vectors)</b>							
<b>DISPLAY (diS)</b>											
<b>LOC</b>	LOCK. Setpoint edit lock. <b>no</b> = no; <b>yES</b> = yes.	flag	no/yES	no	no	no	no	no	no	no	no
<b>ndt</b>	Display with decimal point. <b>no</b> = no; <b>yES</b> = yes.	flag	no/yES	yES	yES	yES	yES	yES	yES	yES	yES
<b>CA1</b>	Probe <b>Pb1</b> calibration.	°C/°F	-30.0...30.0	0.0	0.0	0.0	0.0	0.0	0.0	0.0	0.0
<b>CA2</b>	Probe <b>Pb2</b> calibration.	°C/°F	-30.0...30.0	0.0	0.0	0.0	0.0	0.0	0.0	0.0	0.0
<b>CA3</b>	Probe <b>Pb3</b> calibration.	°C/°F	-30.0...30.0	0.0	0.0	0.0	0.0	0.0	0.0	0.0	0.0
<b>CA4</b>	Probe <b>Pb4</b> calibration.	°C/°F	-30.0...30.0	0.0	0.0	0.0	0.0	0.0	0.0	0.0	0.0



PAR.	DESCRIPTION	UM	RANGE	AP1	AP2	AP3	AP4	AP5	AP6	AP7	AP8
<b>CA5</b>	Probe <b>Pb5</b> calibration.	°C/°F	-30.0...30.0	0.0	0.0	0.0	0.0	0.0	0.0	0.0	0.0
<b>LdL</b>	Minimum value that can be displayed by the device.	°C/°F	-58.0 ... HdL	-40.0	-40.0	-40.0	-40.0	-40.0	-40.0	-40.0	-40.0
<b>HdL</b>	Maximum value that can be displayed by the device.	°C/°F	LdL ... 302.0	20.0	20.0	20.0	20.0	20.0	20.0	20.0	20.0
<b>ddl</b>	Display mode during defrost.	num	0/1/2	0	0	0	0	0	0	0	0
<b>Ldd</b>	Timeout value for display unlock - label <b>dEF</b> .	min	0 ... 250	0	0	0	0	0	0	0	0
<b>ddd</b>	Selects type of value to display.	num	SP1, Pb1... Pb5, Pbi, LP	Pbi	Pb1	Pb1	Pb1	Pb1	Pb1	Pb1	Pb1
<b>HACCP (HCP)</b>											
<b>rPH</b>	Selects which probe will be used by the HACCP alarms.	num	diS, Pb1 ... Pb5	diS	diS	diS	diS	diS	diS	diS	diS
<b>CONFIGURATION (CnF)</b> → If one or more of the parameters in the folder are changed, the controller <b>MUST</b> be switched off and on again.											
<b>H00</b>	Select type of probe used (Pb1 ... Pb5). <b>ntc</b> = NTC; <b>Ptc</b> = PTC; <b>Pt1</b> = PT1000	num	ntc/Ptc/Pt1	ntc	ntc	ntc	ntc	ntc	ntc	ntc	ntc
<b>H08</b>	Function when in standby mode.	num	0/1/2	2	2	2	2	2	2	2	2
<b>H15</b>	Configuration of digital input 5/polarity (PB5).	num	-17 ... 17	0	0	0	0	0	0	0	0
<b>H16</b>	Configuration of digital input 6/polarity (DI2). Same as <b>H15</b> .	num	-17 ... 17	0	0	0	0	0	0	0	0
<b>H17</b>	Configuration of digital input 7/polarity (DI3). Same as <b>H15</b> .	num	-17 ... 17	0	0	0	0	0	0	0	0
<b>H18</b>	Configuration of digital input 8/polarity (DI1). Same as <b>H15</b> .	num	-17 ... 17	0	8	0	0	0	8	0	8
<b>d15</b>	Delay to activate digital input 5 (PB5).	min	0 ... 255	0	0	0	0	0	0	0	0
<b>d16</b>	Delay to activate digital input 6 (DI2).	min	0 ... 255	0	0	0	0	0	0	0	0
<b>d17</b>	Delay to activate digital input 7 (DI3).	min	0 ... 255	0	0	0	0	0	0	0	0
<b>d18</b>	Delay to activate digital input 8 (DI1).	min	0 ... 255	0	0	0	0	0	0	0	0
<b>H24</b>	Configuration of digital output 4 (OUT 4).	num	0 ... 13	5	4	4	4	4	4	4	4
<b>H25</b>	Configuration of digital output 5 (OUT 5).	num	0 ... 13	7	7	7	7	7	7	7	7
<b>H26</b>	Configuration of digital output 6 (OUT 6).	num	0 ... 13	4	0	0	0	0	0	13	0
<b>H27</b>	Configuration of digital output 7 (Open Collector). Same as <b>H24</b> .	num	0 ... 13	8	8	8	8	8		8	0
<b>H32</b>	DOWN key configuration.	num	0 ... 8						0		
<b>H33</b>	ESC key configuration. Analogo a <b>H32</b> .	num	0 ... 8	6	6	6	6	6	6	6	6
<b>H50</b>	Configuration of analogue output type. 010: 0-10V output; 420: 4-20mA output;	flag	010/420								0
<b>H51</b>	Regulator associated with analogue output; diS=disabled FH=Frame Heater	flag	diS/FH								1
<b>H60</b>	Display of selected application.	num	0 ... 8	1 (Parameter not present in vectors)							
<b>H70</b>	Select 1st probe to use as virtual probe.	num	diS, Pb1 ... Pb5	Pb1							
<b>H71</b>	Select 2nd probe to use as virtual probe. Same as <b>H70</b> .	num	0 ... 5	Pb2							
<b>H72</b>	% calculation used by day virtual probe	%	0 ... 100	50							
<b>H73</b>	% calculation used by night virtual probe (in Energy Saving mode)	%	0 ... 100	50							
<b>COPY CARD (FPr)</b>											
<b>UL</b>	Upload. Transfer programming parameters from instrument to Copy Card.	/	/	/ (Parameter not present in vectors)							
<b>dL</b>	Download. Transfer programming parameters from Copy Card to instrument.	/	/	/ (Parameter not present in vectors)							
<b>Fr</b>	Formatting. Delete data on Copy Card.	/	/	/ (Parameter not present in vectors)							
<b>FUNCTION (FnC)</b>											

The following functions are available:

Function	Function label ACTIVE	Function label not active	Alarm signaling
Manual defrost	dEF + LED blinking	dEF	Blinking Defrost icon
AUX (ON = on; OFF = off)	Aon	AoF	AUX ON icon
Reset pressure switch alarms	rAP	rAP	Alarm ON icon
Stand-by	OFF	OFF	Stand-by ON Led (KDWPlus only)

- NOTES:
- To modify the status of a given function, press the 'set' key
  - If the instrument is switched off, the function labels will return to the default status.

**NOTES:** \* The parameters in the "USER" menu include PA2 which gives access to "Installer" menu.  
 \*\* For the full list of parameters, see the "Installer Menu Parameters Table".



## 6.1.2 - "INSTALLER" MENU PARAMETERS TABLE

PAR.	DESCRIPTION	UM	RANGE	AP1	AP2	AP3	AP4	AP5	AP6	AP7	AP8
SP1	Temperature control SETpoint <b>The SETpoint is only visible in the "machine status" menu.</b>	°C/°F	-58.0...302	3.0	-22.0	-22.0	3.0	-22.0	-22.0	-22.0	-22.0
SP2	Temperature control SETpoint second thermostat (only if <b>rE≠0</b> ). <b>The SETpoint is only visible in the "machine status" menu.</b>	°C/°F	-58.0...302	0.0	0.0	0.0	0.0	-22.0	0.0	0.0	0.0
<b>COMPRESSOR (CP)</b>											
rE	Sets the type of control to be performed: <b>0</b> : single thermostat <b>1</b> : double thermostat in series <b>2</b> : double thermostat in parallel <b>3</b> : 2-step regulator <b>4</b> : two independent regulators	num	0 ... 4	0	0	0	0	2	0	0	0
rP1	Sets regulation probe 1. <b>diS</b> (0) = disabled <b>Pb1</b> (1) = will use probe Pb1 <b>Pb2</b> (2) = will use probe Pb2 <b>Pb3</b> (3) = will use probe Pb3 <b>Pb4</b> (4) = will use probe Pb4 <b>Pb5</b> (5) = will use probe Pb5 <b>Pbi</b> (6) = will use the virtual probe <b>LP</b> (7) = will use the remote probe	num	dis Pb1 Pb2 Pb3 Pb4 Pb5 Pbi LP	Pbi	Pb1	Pb1	Pb1	Pb1	Pb1	Pb1	Pb1
rP2	Sets control probe of thermostat 2 (only if <b>rE ≠ 0</b> ). <b>diS</b> (0) = disabled <b>Pb1</b> (1) = will use probe Pb1 <b>Pb2</b> (2) = will use probe Pb2 <b>Pb3</b> (3) = will use probe Pb3 <b>Pb4</b> (4) = will use probe Pb4 <b>Pb5</b> (5) = will use probe Pb5	num	dis Pb1 Pb2 Pb3 Pb4 Pb5	diS	diS	diS	diS	Pb2	diS	diS	diS
dF1	Activation differential (absolute or relative). <b>N.B.: dF1 cannot be equal to 0.</b>	°C/°F	-58.0...302	4.0	4.0	4.0	4.0	4.0	4.0	4.0	4.0
dF2	Thermostat 2 activation differential (absolute or relative) (only if <b>rE ≠ 0</b> ). <b>Note: dF2 cannot be equal to 0.</b>	°C/°F	-58.0...302	0.0	0.0	0.0	0.0	40.0	0.0	0.0	0.0
Stt	Differential management mode dF1 and dF2. <b>AbS</b> (0) = absolute value <b>rEL</b> (1) = relative value	flag	AbS/rEL	rEL	rEL	rEL	rEL	rEL	rEL	rEL	rEL
HS1	Maximum value assignable to setpoint SP1. <b>NOTE: The two setpoints are interdependent: HS1 cannot be less than LS1 and vice versa.</b>	°C/°F	LS1...302	20.0	0.0	0.0	20.0	0.0	0.0	0.0	0.0
LS1	Minimum value assignable to setpoint SP1. <b>NOTE: The two setpoints are interdependent: LS1 cannot be greater than HS1 and vice versa.</b>	°C/°F	-58.0... HS1	-10.0	-35.0	-35.0	-10.0	-35.0	-35.0	-35.0	-35.0
HS2	Maximum value assignable to setpoint SP2. (only if <b>rE ≠ 0</b> ). <b>NOTE: The two setpoints are interdependent: HS2 cannot be less than LS2 and vice versa.</b>	°C/°F	LS2...302	0.0	0.0	0.0	0.0	0.0	0.0	0.0	0.0
LS2	Minimum value assignable to setpoint SP2. (only if <b>rE ≠ 0</b> ). <b>NOTE: The two setpoints are interdependent: LS2 cannot be greater than HS2 and vice versa.</b>	°C/°F	-58.0... HS2	0.0	0.0	0.0	0.0	-35.0	0.0	0.0	0.0
HC1	Selects thermostat 1 regulation mode. <b>C</b> (0) = Cool, <b>H</b> (1) = Heat.	flag	C/H	C	C	C	C	C	C	C	C
HC2	Selects thermostat 2 regulation mode. <b>C</b> (0) = Cool, <b>H</b> (1) = Heat. (only if <b>rE≠0</b> ).	flag	C/H	C	C	C	C	C	C	C	C
CC	Double power step control (activated only if <b>rE = 3</b> ). <b>0</b> : sequential activation; <b>1</b> : balancing of running hours.	num	0/1	0	0	0	0	0	0	0	0
Cit	Compressor minimum running time before switching off. If <b>Cit = 0</b> it is not active.	min	0 ... 250	5	5	5	5	5	5	5	5
CAt	Compressor maximum running time before switching off. If <b>CAt = 0</b> it is not active.	min	0 ... 250	0	0	0	0	0	0	0	0
Ont	Controller switch-on time in the event of faulty probe. - if <b>Ont = 1</b> and <b>OFt = 0</b> , the compressor stays on permanently (ON). - if <b>Ont &gt; 0</b> and <b>OFt &gt; 0</b> , it operates in Duty Cycle mode.	min	0 ... 250	3	3	3	3	3	3	3	3
OFt	Controller switch-off time in the event of a faulty probe. - if <b>OFt = 1</b> and <b>Ont = 0</b> , the compressor will always stay off (OFF). - if <b>Ont &gt; 0</b> and <b>OFt &gt; 0</b> , it operates in Duty Cycle mode.	min	0 ... 250	3	3	3	3	3	3	3	3
dOn	Delay time between switch-ons; the delay time indicated must elapse between two consecutive compressor switch-ons.	min	0 ... 250	0	0	0	0	0	0	0	0



PAR.	DESCRIPTION	UM	RANGE	AP1	AP2	AP3	AP4	AP5	AP6	AP7	AP8
<b>dOf</b>	Delay time after switch off: the delay time indicated must elapse between deactivation of the compressor relay and the next switch-on.	min	0 ... 250	2	2	2	2	2	2	2	2
<b>dbi</b>	Delay time between switch-ons; the delay time indicated must elapse between two consecutive compressor switch-ons.	min	0 ... 250	0	0	0	0	0	0	0	0
<b>OdO</b>	Delay in activating outputs after the instrument is switched on or after a power failure. <b>0 = not active</b>	min	0 ... 250	0	0	0	0	0	0	0	0
<b>CP2</b>	compressor 2 switch-on delay.	sec	0 ... 250	0	0	0	0	0	0	0	0
<b>CS2</b>	Power step 2 switch-on delay. (only if <b>rE</b> ≠ <b>3</b> ).	min	0 ... 250	0	0	0	0	0	0	0	0
<b>CFP</b>	Condenser fan prevention time in Cool/Heat	sec	0 ... 255	0	0	0	0	0	0	0	0
<b>Cfd</b>	Condenser fans during defrost mode. <b>0 = OFF; 1 = ON</b> .	num	0/1	0	0	0	0	0	0	0	0
<b>OF1</b>	Forced remote offset Represents the value (Offset) that will be added to or subtracted from the regulator 1 SEt (SP1) in the presence of remote commands: <b>nOS</b> = Activate force setpoint offset ( <b>SEt = SP1+OF1</b> ) <b>oOS</b> = Disable force setpoint offset ( <b>SEt = SP1</b> )	°C/°F	-50.0...50.0	0.0	0.0	0.0	0.0	0.0	0.0	0.0	0.0
<b>DEFROST (dEF)</b>											
<b>dP1</b>	Selects which probe will be used by defrost 1: <b>diS</b> (0) = disabled <b>Pb1</b> (1) = will use probe Pb1 <b>Pb2</b> (2) = will use probe Pb2 <b>Pb3</b> (3) = will use probe Pb3 <b>Pb4</b> (4) = will use probe Pb4 <b>Pb5</b> (5) = will use probe Pb5 <b>Pbi</b> (6) = will use the virtual probe <b>LP</b> (7) = will use the remote probe	num	diS Pb1 Pb2 Pb3 Pb4 Pb5 Pbi LP	Pb3	Pb3	Pb3	Pb3	Pb3	Pb3	Pb3	Pb3
<b>dP2</b>	Selects which probe will be used by defrost 2. Same as <b>dP1</b> .	num	diS, Pb1 ... Pb5, Pbi, LP	diS	diS	diS	diS	diS	diS	diS	diS
<b>dtY</b>	defrost type. Type of defrost. <b>0</b> = electrical defrost (using heaters) <b>1</b> = inverse cycle defrost <b>2</b> = hot gas defrost for plug-in applications (with integrated compressor). <b>3</b> = hot gas defrost for applications with remote control (e.g. ducted counters). <b>4</b> = electrical defrost (using heaters) with energy-saving algorithms (smart defrost)	num	0 ... 4	4	4	4	4	4	0	2	4
<b>dFt</b>	Defrost activation mode using 2 probes: <b>0</b> = activation linked solely to probe 1 <b>1</b> = activation on request of at least one of the two probes <b>2</b> = activation on request of both probes	num	0/1/2	0	0	0	0	0	0	0	0
<b>dit</b>	Interval between the start of two consecutive defrost cycles. <b>0</b> = function disabled ( <b>defrost NEVER run</b> ).	hours	0 ... 250	0	0	0	0	0	0	0	0
<b>dt1</b>	defrost time 1. Unit of measure for defrost interval (parameter <b>dit</b> ). <b>0</b> = parameter dit in hours. <b>1</b> = parameter dit in minutes. <b>2</b> = parameter dit in seconds.	num	0/1/2	0	0	0	0	0	0	0	0
<b>dt2</b>	defrost time 2. Unit of measure for duration of defrost (parameters <b>dE1/dE2</b> ). (only if <b>dFt</b> ≠ <b>0</b> ). <b>0</b> = parameter dE1/dE2 in hours. <b>1</b> = parameter dE1/dE2 in minutes. <b>2</b> = parameter dE1/dE2 in seconds.	num	0/1/2	1	1	1	1	1	1	1	1
<b>dCt</b>	Selects the count mode for the defrost interval: <b>0</b> = defrost disabled <b>1</b> = compressor running time (DIGIFROST® method); defrost active ONLY when the compressor is on. <b>NOTE:</b> compressor running hours are counted separately from the evaporator probe (count active also when evaporator probe missing or faulty). <b>2</b> = appliance running time; defrost counting is always active when the machine is on and starts at each power-on; <b>3</b> = compressor stop. Every time the compressor stops, a defrost cycle is performed according to parameter dtY; <b>4</b> = RTC <b>5</b> = temperature	num	0 ... 5	4	4	4	4	4	4	4	4



Param.	DESCRIPTION	UM	RANGE	AP1	AP2	AP3	AP4	AP5	AP6	AP7	AP8
<b>dOH</b>	Delay for start of first defrost after request.	min	0 ... 250	0	0	0	0	0	0	0	0
<b>dE1</b>	Evaporator 1 defrost time-out. Determines the maximum duration of defrost for evaporator 1.	min	1 ... 250	30	30	30	30	30	30	30	30
<b>dE2</b>	Evaporator 2 defrost time-out. (only if <b>dFt</b> ≠ 0). Determines the maximum duration of defrost for evaporator 2.	min	1 ... 250	1	1	1	1	1	1	1	1
<b>dS1</b>	Defrost 1 end temperature (determined by the 1st evaporator probe).	°C/°F	-58.0...302	7.0	7.0	7.0	7.0	7.0	12.0	12.0	7.0
<b>dS2</b>	Defrost 2 end temperature (determined by the 2nd evaporator probe). (only if <b>dp2</b> ≠ dis).	°C/°F	-58.0...302	7.0	7.0	7.0	7.0	7.0	12.0	12.0	7.0
<b>dSS</b>	Start defrost temperature threshold (only if dCt = 5 - temperature).	°C/°F	-58.0...302	-5.0	-30.0	-30.0	-5.0	-30.0	-30.0	-30.0	-30.0
<b>dPO</b>	Determines whether the instrument must enter defrost mode (if the temperature measured by the evaporator allows this operation). <b>no</b> = no, does not defrost at switch on <b>yES</b> = yes, defrost at switch on.	flag	no/yES	no	no	no	no	no	no	no	no
<b>tcd</b>	Minimum time that must elapse with the compressor ON or OFF before defrost is activated.	min	-60 ... 60	0	0	0	0	0	0	3	0
<b>ndE</b>	Defrost duration in minutes (only if set "for hot gas").	min	0 ... 250	0	0	0	0	0	0	15	0
<b>PdC</b>	Hot gas extraction time at defrost end.	min	0 ... 250	0	0	0	0	0	0	0	0
<b>tPd</b>	Minimum pump down time that must elapse before defrost starts.	min	0 ... 255	0	0	0	0	0	0	0	0
<b>dPH</b>	Periodic defrost start time. <b>0 ... 23</b> = start hour; <b>24</b> = disabled.	hours	0 ... 24	24	24	24	24	24	24	24	24
<b>dPn</b>	Periodic defrost start minutes.	min	0 ... 59	0	0	0	0	0	0	0	0
<b>dPd</b>	Interval between one defrost and next (periodic function).	days	1 ... 7	1	1	1	1	1	1	1	1
<b>Fd1</b>	1st holiday. <b>0 ... 6</b> = start day; <b>7</b> = disabled.	days	0 ... 7	0	0	0	0	0	0	0	0
<b>Fd2</b>	2nd holiday. <b>0 ... 6</b> = start day; <b>7</b> = disabled.	days	0 ... 7	7	7	7	7	7	7	7	7
<b>Edt</b>	To set customized durations and temperatures for each event. <b>no</b> (0) = all values equal; <b>yES</b> (1) = customized values for each event (only if <b>dCt</b> = 4).	flag	no/yES	no	no	no	no	no	no	no	no
<b>d1H</b>	Start time weekday defrost 1. <b>0 ... 23</b> = start hour; <b>24</b> = disabled.	hours	0 ... 24	7	0	0	7	0	7	0	0
<b>d1n</b>	1st workday defrost start minutes.	min	0 ... 59	0	0	0	0	0	0	0	0
<b>d1t</b>	Weekday defrost 1 duration.	min	0 ... 250	0	0	0	0	0	0	0	0
<b>d1S</b>	End of weekday defrost 1 temperature.	°C/°F	-58.0...302	0.0	0.0	0.0	0.0	0.0	0.0	0.0	0.0
<b>d2H</b>	Start time weekday defrost 2. <b>d1H ... 23</b> = start hour; <b>24</b> = disabled.	hours	0 ... 24	21	6	6	21	6	21	6	6
<b>d2n</b>	2nd workday defrost start minutes.	min	0 ... 59	0	0	0	0	0	0	0	0
<b>d2t</b>	Weekday defrost 2 duration.	min	0 ... 250	0	0	0	0	0	0	0	0
<b>d2S</b>	End of weekday defrost 2 temperature.	°C/°F	-58.0...302	0.0	0.0	0.0	0.0	0.0	0.0	0.0	0.0
<b>d3H</b>	Start time weekday defrost 3. <b>d2H ... 23</b> = start hour; <b>24</b> = disabled.	hours	0 ... 24	24	12	12	24	12	24	12	12
<b>d3n</b>	3rd workday defrost start minutes.	min	0 ... 59	0	0	0	0	0	0	0	0
<b>d3t</b>	Weekday defrost 3 duration.	min	0 ... 250	0	0	0	0	0	0	0	0
<b>d3S</b>	End of weekday defrost 3 temperature.	°C/°F	-58.0...302	0.0	0.0	0.0	0.0	0.0	0.0	0.0	0.0
<b>d4H</b>	Start time weekday defrost 4. <b>d3H ... 23</b> = start hour; <b>24</b> = disabled.	hours	0 ... 24	24	18	18	24	18	24	18	18
<b>d4n</b>	4th workday defrost start minutes.	min	0 ... 59	0	0	0	0	0	0	0	0
<b>d4t</b>	Weekday defrost 4 duration.	min	0 ... 250	0	0	0	0	0	0	0	0
<b>d4S</b>	End of weekday defrost 4 temperature.	°C/°F	-58.0...302	0.0	0.0	0.0	0.0	0.0	0.0	0.0	0.0
<b>d5H</b>	Start time weekday defrost 5. <b>d4H ... 23</b> = start hour; <b>24</b> = disabled.	hours	0 ... 24	24	24	24	24	24	24	24	24
<b>d5n</b>	5th workday defrost start minutes.	min	0 ... 59	0	0	0	0	0	0	0	0
<b>d5t</b>	Weekday defrost 5 duration.	min	0 ... 250	0	0	0	0	0	0	0	0
<b>d5S</b>	End of weekday defrost 5 temperature.	°C/°F	-58.0...302	0.0	0.0	0.0	0.0	0.0	0.0	0.0	0.0
<b>d6H</b>	Start time weekday defrost 6. <b>d5H ... 23</b> = start hour; <b>24</b> = disabled.	hours	0 ... 24	24	24	24	24	24	24	24	24
<b>d6n</b>	6th workday defrost start minutes.	min	0 ... 59	0	0	0	0	0	0	0	0
<b>d6t</b>	Weekday defrost 6 duration.	min	0 ... 250	0	0	0	0	0	0	0	0
<b>d6S</b>	End of weekday defrost 6 temperature.	°C/°F	-58.0...302	0.0	0.0	0.0	0.0	0.0	0.0	0.0	0.0
<b>F1H</b>	1st holiday defrost start hour. <b>0 ... 23</b> = start hour; <b>24</b> = disabled.	hours	0 ... 24	12	0	0	12	0	12	0	0
<b>F1n</b>	1st holiday defrost start minutes.	min	0 ... 59	0	0	0	0	0	0	0	0
<b>F1t</b>	Weekend/public holiday defrost 1 duration.	min	0 ... 250	0	0	0	0	0	0	0	0
<b>F1S</b>	End of weekend/public holiday defrost 1 temperature.	°C/°F	-58.0...302	0.0	0.0	0.0	0.0	0.0	0.0	0.0	0.0
<b>F2H</b>	2nd holiday defrost start hour. <b>F1H ... 23</b> = start hour; <b>24</b> = disabled.	hours	0 ... 24	23	6	6	23	6	23	6	6
<b>F2n</b>	2nd holiday defrost start minutes.	min	0 ... 59	0	0	0	0	0	0	0	0
<b>F2t</b>	Weekend/public holiday defrost 2 duration.	min	0 ... 250	0	0	0	0	0	0	0	0
<b>F2S</b>	End of weekend/public holiday defrost 2 temperature.	°C/°F	-58.0...302	0.0	0.0	0.0	0.0	0.0	0.0	0.0	0.0
<b>F3H</b>	Start time weekend/public holiday defrost 3. <b>F2H ... 23</b> = start hour; <b>24</b> = disabled.	hours	0 ... 24	24	12	12	24	12	24	12	12
<b>F3n</b>	3rd holiday defrost start minutes.	min	0 ... 59	0	0	0	0	0	0	0	0
<b>F3t</b>	Weekend/public holiday defrost 3 duration.	min	0 ... 250	0	0	0	0	0	0	0	0
<b>F3S</b>	End of weekend/public holiday defrost 3 temperature.	°C/°F	-58.0...302	0.0	0.0	0.0	0.0	0.0	0.0	0.0	0.0



Param.	DESCRIPTION	UM	RANGE	AP1	AP2	AP3	AP4	AP5	AP6	AP7	AP8	
<b>F4H</b>	Start time weekend/public holiday defrost 4. <b>F3H ... 23</b> = start hour; <b>24</b> = disabled.	hours	0 ... 24	24	18	18	24	18	24	18	18	
<b>F4n</b>	4th holiday defrost start minutes.	min	0 ... 59	0	0	0	0	0	0	0	0	
<b>F4t</b>	Weekend/public holiday defrost 4 duration.	min	0 ... 250	0	0	0	0	0	0	0	0	
<b>F4S</b>	End of weekend/public holiday defrost 4 temperature.	°C/°F	-58.0...302	0.0	0.0	0.0	0.0	0.0	0.0	0.0	0.0	
<b>F5H</b>	Start time weekend/public holiday defrost 5. <b>F4H ... 23</b> = start hour; <b>24</b> = disabled.	hours	0 ... 24	24	24	24	24	24	24	24	24	
<b>F5n</b>	5th holiday defrost start minutes.	min	0 ... 59	0	0	0	0	0	0	0	0	
<b>F5t</b>	Weekend/public holiday defrost 5 duration.	min	0 ... 250	0	0	0	0	0	0	0	0	
<b>F5S</b>	End of weekend/public holiday defrost 5 temperature.	°C/°F	-58.0...302	0.0	0.0	0.0	0.0	0.0	0.0	0.0	0.0	
<b>F6H</b>	Start time weekend/public holiday defrost 6. <b>F5H ... 23</b> = start hour; <b>24</b> = disabled.	hours	0 ... 24	24	24	24	24	24	24	24	24	
<b>F6n</b>	6th holiday defrost start minutes.	min	0 ... 59	0	0	0	0	0	0	0	0	
<b>F6t</b>	Weekend/public holiday defrost 6 duration.	min	0 ... 250	0	0	0	0	0	0	0	0	
<b>F6S</b>	End of weekend/public holiday defrost 6 temperature.	°C/°F	-58.0...302	0.0	0.0	0.0	0.0	0.0	0.0	0.0	0.0	
<b>FANS (FAn)</b>												
<b>FP1</b>	Selects which probe to be used by evaporator fans during normal function: <b>diS</b> (0) = disabled <b>Pb1</b> (1) = will use probe Pb1 <b>Pb2</b> (2) = will use probe Pb2 <b>Pb3</b> (3) = will use probe Pb3 <b>Pb4</b> (4) = will use probe Pb4 <b>Pb5</b> (5) = will use probe Pb5 <b>Pbi</b> (6) = will use the virtual probe <b>LP</b> (7) = will use the remote probe	num	diS Pb1 Pb2 Pb3 Pb4 Pb5 Pbi LP	diS	diS	Pb3	Pb3	Pb3	Pb3	Pb3	diS	
<b>FP2</b>	Selects which probe to be used by evaporator fans during defrost. Same as <b>FP1</b> .	num	diS, Pb1...Pb5, Pbi, LP	diS	diS	diS	diS	diS	diS	diS	diS	
<b>FPt</b>	FSt parameter management mode. <b>AbS</b> (0) = absolute value; <b>rEL</b> (1) = relative value	flag	AbS/rEL	AbS	AbS	AbS	AbS	AbS	AbS	AbS	AbS	
<b>FSt</b>	Fans block temperature; if the value read is greater than FSt, the fans are stopped. The value is positive or negative (only if <b>FP1</b> ≠ <b>diS</b> ).	°C/°F	-58.0...302	0.0	0.0	0.0	0.0	0.0	0.0	0.0	0.0	
<b>FAd</b>	Fan activation differential (only if <b>FP1</b> ≠ <b>diS</b> ).	°C/°F	0.1 ... 25.0	0.1	0.1	4.0	4.0	4.0	4.0	4.0	0.1	
<b>Fdt</b>	Fans activation delay after a defrost cycle.	min	0 ... 250	0	0	0	0	0	1	0	0	
<b>dt</b>	drainage time. Coil drainage time.	min	0 ... 250	0	5	5	5	5	5	3	0	
<b>dFd</b>	Evaporator fans operating mode during defrost. <b>OFF</b> (0) = Fans Off; <b>On</b> (1) = Fans On.	flag	OFF/On	On	On	On	On	On	On	OFF	On	
<b>FCO</b>	Evaporator fans operating mode. The state of the fans will be:											
			<b>DAY</b>		<b>NIGHT</b>							
		<b>FP1</b>	<b>FCO</b>	<b>COMPRESSOR ON</b>	<b>COMPRESSOR OFF</b>	<b>COMPRESSOR ON</b>	<b>COMPRESSOR OFF</b>					
	<b>FP1 present</b>		0	Thermostat controlled	OFF	Thermostat controlled	OFF					
			1	Thermostat controlled	Thermostat controlled	Thermostat controlled	Thermostat controlled					
			2	Thermostat controlled	Thermostat controlled	Thermostat controlled	Thermostat controlled					
			3	Thermostat controlled	duty cycle Day	Thermostat controlled	duty cycle Night					
	<b>FP1 absent</b>		4	Thermostat controlled	duty cycle Day	Thermostat controlled	duty cycle Night					
			0	ON	OFF	ON	OFF					
			1	ON	ON	ON	ON					
			2	duty cycle Day	duty cycle Day	duty cycle Night	duty cycle Night					
		3	ON	duty cycle Day	ON	duty cycle Night						
	4	ON	duty cycle Day	ON	duty cycle Night							
<b>Duty cycle Day:</b> controlled by means of parameters " <b>FOn</b> " and " <b>FOF</b> ".												
<b>Duty cycle Night:</b> controlled by means of parameters " <b>Fnn</b> " and " <b>FnF</b> ".												
<b>FdC</b>	Evaporator fans switch-off delay after compressor disabled.	min	0 ... 250	0	0	0	0	0	5	0	0	
<b>FOn</b>	Fan ON time in duty cycle day. Fans used in duty cycle mode; applies to <b>FCO = dc</b> and <b>FP1</b> is present.	min	0 ... 250	1	1	1	1	1	1	1	1	
<b>FOF</b>	Fan OFF time in duty cycle day. Fans used in duty cycle mode; applies to <b>FCO = dc</b> and <b>FP1</b> is present.	min	0 ... 250	0	0	0	0	0	0	0	0	
<b>Fnn</b>	Fan ON time in duty cycle night. Fans used in duty cycle mode; applies to <b>FCO = dc</b> and <b>FP1</b> is present.	min	0 ... 250	1	2	1	1	1	1	1	2	
<b>FnF</b>	Fan OFF time in duty cycle night. Fans used in duty cycle mode; applies to <b>FCO = dc</b> and <b>FP1</b> is present.	min	0 ... 250	0	2	0	0	0	0	0	2	



Param.	DESCRIPTION	UM	RANGE	AP1	AP2	AP3	AP4	AP5	AP6	AP7	AP8
<b>ALARMS (AL)</b>											
<b>rA1</b>	Selects probe 1 which will be used for temperature alarms: <b>diS</b> (0) = disabled <b>Pb1</b> (1) = will use probe Pb1 <b>Pb2</b> (2) = will use probe Pb2 <b>Pb3</b> (3) = will use probe Pb3 <b>Pb4</b> (4) = will use probe Pb4 <b>Pb5</b> (5) = will use probe Pb5 <b>Pbi</b> (6) = will use the virtual probe	num	diS Pb1 Pb2 Pb3 Pb4 Pb5 Pbi	Pbi	Pb1	Pb1	Pb1	Pb1	Pb1	Pb1	Pb1
<b>rA2</b>	Selects probe 2 which will be used for temperature alarms. Same as <b>rA1</b> .	num	diS, Pb1 ... Pb5, Pbi	diS	diS	diS	diS	Pb2	diS	diS	diS
<b>Att</b>	Parameters <b>HAL</b> and <b>LAL</b> mode intended as the absolute temperature value or differential in relation to the setpoint. <b>AbS</b> (0) = absolute value <b>rEL</b> (1) = relative value <b>NOTE:</b> <b>In case of relative values (para. Att=1), the HAL parameter should be set to positive values, while the LAL parameter should be set to negative values (-LAL).</b>	flag	AbS/rEL	rEL	rEL	rEL	rEL	rEL	rEL	rEL	rEL
<b>AfD</b>	Alarm activation differential.	°C/°F	0.1 ... 25.0	4.0	4.0	4.0	4.0	4.0	4.0	4.0	4.0
<b>HA1</b>	Probe 1 maximum alarm. Temperature value (intended as the distance from the setpoint or absolute value in relation to <b>Att</b> ), which when exceeded will generate an alarm signal.	°C/°F	LA1...302	5.0	5.0	5.0	5.0	5.0	5.0	5.0	5.0
<b>LA1</b>	Probe 1 minimum alarm. Temperature value (intended as the distance from the setpoint or absolute value in relation to <b>Att</b> ), which will generate an alarm signal when the value read drops below it.	°C/°F	-58.0... HA1	-5.0	-5.0	-5.0	-5.0	-5.0	-5.0	-5.0	-5.0
<b>HA2</b>	Probe 2 maximum alarm. Temperature value (intended as the distance from the setpoint or absolute value in relation to <b>Att</b> ), which when exceeded will generate an alarm signal (only if <b>rA2</b> ≠ <b>dis</b> ).	°C/°F	LA2...302	0.0	0.0	0.0	0.0	5.0	0.0	0.0	0.0
<b>LA2</b>	Probe 2 minimum alarm. Temperature value (intended as the distance from the setpoint or absolute value in relation to <b>Att</b> ), which will generate an alarm signal when the value read drops below it. (only if <b>rA2</b> ≠ <b>dis</b> ).	°C/°F	-58.0... HA2	0.0	0.0	0.0	0.0	-5.0	0.0	0.0	0.0
<b>PAO</b>	Alarm override time after device is switched on following a power failure. <b>This parameter refers to high/low temperature alarms only.</b>	hours	0 ... 10	3	3	3	3	3	3	3	3
<b>dAO</b>	Temperature alarm exclusion time after defrost.	min	0 ... 250	30	30	30	30	30	30	30	30
<b>OA0</b>	Alarm signal delay (low and high temperature) after the deactivation of the digital input (port closed).	hours	0 ... 10	0	0	0	0	0	10	0	0
<b>td0</b>	Delay in door open alarm activation.	min	0 ... 250	0	0	0	0	0	10	0	0
<b>tA1</b>	Time delay for temperature alarm indication. <b>This parameter refers to high/low temperature alarms LA1 and HA1 only.</b>	min	0 ... 250	0	0	0	0	0	0	0	0
<b>tA2</b>	Temperature alarm signal delay (only if <b>rA2</b> ≠ <b>dis</b> ) <b>This parameter refers to high/low temperature alarms LA2 and HA2 only.</b>	min	0 ... 250	0	0	0	0	0	0	0	0
<b>dAt</b>	Alarm signalling end of defrost due to timeout. <b>no</b> (0) = does not activate alarm <b>yES</b> (1) = activates alarm.	flag	no/yES	no	no	no	no	no	no	no	no
<b>EAL</b>	Regulators blocked by external alarm. <b>0</b> = does not block any resource <b>1</b> = blocks the compressor and defrost <b>2</b> = blocks compressor, defrost and fans	num	0/1/2	0	0	0	0	0	0	0	0
<b>tP</b>	All keys acknowledge an alarm. <b>no</b> (0) = no <b>yES</b> (1) = yes.	flag	no/yES	no	no	no	no	no	no	no	no
<b>Art</b>	Alarm activation period LINK <sup>2</sup> supervision. <b>0</b> = disabled. Sets every how many minutes the system checks network function. The alarm ( <b>AtS</b> ) is not displayed and is reset automatically after 5 minutes if <b>Art</b> = <b>1</b> and after 10 seconds if <b>Art</b> ≥ <b>2</b> .	min*10	0 ... 250	0	0	0	0	0	0	0	0
<b>LIGHTS &amp; DIGITAL INPUTS (Lit)</b>											
<b>dSd</b>	Enable light relay from door switch. <b>no</b> (0) = opening the door does not switch on the light. <b>yES</b> (1) = opening the door switches on the light (if it was off).	flag	no/yES	no	no	no	no	no	yES	no	no
<b>dLt</b>	Light relay (room light) deactivation (switch-off) delay. The light relay remains on for dLt minutes when the door is closed if parameter <b>dSd</b> is set to switch on the light.	min	0 ... 250	0	0	0	0	0	0	0	0





Param.	DESCRIPTION	UM	RANGE	AP1	AP2	AP3	AP4	AP5	AP6	AP7	AP8
<b>OFL</b>	Light key always disables the light relay. Enables switching off with chiller light switch even if the delay after closing the door set by <b>dLt</b> is enabled. <b>no</b> (0) = no <b>yES</b> (1) = yes.	flag	no/yES	no	no	no	no	no	no	no	no
<b>dOd</b>	Enable utility switch-off on activation of door switch. <b>0</b> = disabled <b>1</b> = disables fans <b>2</b> = compressor disabled <b>3</b> = disables fans and compressor	num	0 ... 3	0	0	0	0	0	1	0	0
<b>dOA</b>	Forced action of digital input (if <b>PEA</b> ≠ 0): <b>0</b> = compressor activated <b>1</b> = fans activated <b>2</b> = compressor and fans activated <b>3</b> = compressor disabled <b>4</b> = fans disabled <b>5</b> = compressor and fans disabled	num	0 ... 5	0	0	0	0	0	2	0	0
<b>PEA</b>	Selection of a digital input with resource blocking/unblocking function. <b>0</b> = function disabled <b>1</b> = associated to door switch <b>2</b> = associated to external alarm <b>3</b> = associated to external alarm and door switch	num	0 ... 3	0	0	0	0	0	1	0	0
<b>dCO</b>	Delay activating/deactivating compressor after request.	min	0 ... 250	0	0	0	0	0	5	0	0
<b>dFO</b>	Delay activating/deactivating fans after request.	min	0 ... 250	0	0	0	0	0	5	0	0
<b>ASb</b>	Activation by key of AUX or LIGHT input when the controller is in standby. <b>no</b> (0) = disables relay until return from stand-by <b>yES</b> (1) = the state of relay doesn't change and it can be activated/disabled from key	flag	no/yES	no	no	no	no	no	no	no	no
<b>LINK<sup>2</sup> (Lin)</b>											
<b>L00</b>	Selects which probe to share: <b>diS</b> (0) = disabled <b>Pb1</b> (1) = will share probe Pb1 <b>Pb2</b> (2) = will share probe Pb2 <b>Pb3</b> (3) = will share probe Pb3 <b>Pb4</b> (4) = will share probe Pb4 <b>Pb5</b> (5) = will share probe Pb5 <b>Pbi</b> (6) = will share the virtual probe	num	diS Pb1 Pb2 Pb3 Pb4 Pb5 Pbi	diS	diS	diS	diS	diS	diS	diS	diS
<b>L01</b>	Shares the displayed value with the LAN. <b>0</b> = prevent the value shown by the device from being sent to the LINK <sup>2</sup> network <b>1</b> = enables sending of the value displayed on the instrument to the LINK <sup>2</sup> network <b>2</b> = shows the value of the device with <b>L01</b> = 1	num	0/1/2	0	0	0	0	0	0	0	0
<b>L02</b>	Sends the setpoint value to the LINK <sup>2</sup> network after it has been modified. <b>no</b> (0) = no <b>yES</b> (1) = yes.	flag	no/yES	no	no	no	no	no	no	no	no
<b>L03</b>	Enables the defrost request to be sent to the LINK <sup>2</sup> network. <b>no</b> (0) = no <b>yES</b> (1) = yes.	flag	no/yES	no	no	no	no	no	no	no	no
<b>L04</b>	Defrost end mode. <b>ind</b> (0) = independent <b>dEP</b> (1) = dependent.	flag	ind/dEP	ind	ind	ind	ind	ind	ind	ind	ind
<b>L05</b>	Enables synchronisation of the Standby command. <b>no</b> (0) = no <b>yES</b> (1) = yes.	flag	no/yES	no	no	no	no	no	no	no	no
<b>L06</b>	Enables synchronisation of the lights command. <b>no</b> (0) = no <b>yES</b> (1) = yes.	flag	no/yES	no	no	no	no	no	no	no	no
<b>L07</b>	Enables synchronization of the Energy Saving command. <b>no</b> (0) = no <b>yES</b> (1) = yes.	flag	no/yES	no	no	no	no	no	no	no	no
<b>L08</b>	Enables synchronisation of the AUX command. <b>no</b> (0) = no <b>yES</b> (1) = yes.	flag	no/yES	no	no	no	no	no	no	no	no
<b>L10</b>	Sets the time delay to be set after the end of dependent defrosts.	min	0 ... 250	30	30	30	30	30	30	30	30



Param.	DESCRIPTION	UM	RANGE	AP1	AP2	AP3	AP4	AP5	AP6	AP7	AP8
<b>PRESSURE SWITCH (folder "PrE")</b>											
<b>PEn</b>	Number of errors allowed per pressure switch input. <b>0</b> = disabled.	num	0 ... 15	0	0	0	0	0	0	0	0
<b>PEi</b>	Pressure switch error count interval.	min	1 ... 250	1	1	1	1	1	1	1	1
<b>DEEP COOLING CYCLE (folder "dEC")</b>											
<b>dCS</b>	Deep Cooling Setpoint.	°C/°F	-58.0...302	0.0	0.0	0.0	0.0	0.0	0.0	0.0	0.0
<b>tdc</b>	Deep Cooling duration.	min	0 ... 250	0	0	0	0	0	0	0	0
<b>dcc</b>	Delay before defrost after a deep cooling cycle.	min	0 ... 250	0	0	0	0	0	0	0	0
<b>ENERGY SAVING (EnS)</b>											
<b>ESt</b>	Type of event activated by RTC: <b>0</b> = disabled <b>1</b> = Energy Saving <b>2</b> = Energy Saving + Light off <b>3</b> = Energy Saving + Light Off + AUX output on <b>4</b> = device off.	num	0 ... 4	3	2	2	2	2	0	2	2
<b>ESF</b>	Night mode (energy saving) activation for fans. <b>no</b> (0) = disabled <b>yES</b> (1) = enabled if energy saving mode on ( <b>ESt</b> ≠ <b>0</b> e <b>ESt</b> ≠ <b>4</b> ).	flag	no yES	no	yES	no	no	no	no	no	yES
<b>Cdt</b>	Door close time.	min*10	0 ... 255	0	0	0	0	0	0	0	30
<b>ESo</b>	Cumulative door opening time to disable Energy Saving mode.	num	0 ... 10	0	0	0	0	0	0	0	5
<b>OS1</b>	Offset setpoint 1 (SP1).	°C/°F	-50.0...50.0	3.0	3.0	3.0	3.0	3.0	3.0	3.0	3.0
<b>OS2</b>	Offset setpoint 2 (SP2). (solo se <b>rE</b> ≠ <b>0</b> )	°C/°F	-50.0...50.0	0.0	0.0	0.0	0.0	3.0	0.0	0.0	0.0
<b>Od1</b>	Energy Saving Offset 1 glass door display cabinets.	°C/°F	-50.0...50.0	0.0	1.0	0.0	0.0	0.0	0.0	0.0	1.0
<b>Od2</b>	Energy Saving Offset 2 glass door display cabinets. (solo se <b>rE</b> ≠ <b>0</b> )	°C/°F	-50.0...50.0	0.0	0.0	0.0	0.0	0.0	0.0	0.0	0.0
<b>dn1</b>	Activation differential 1 in energy saving mode.	°C/°F	-58.0...302	4.0	4.0	4.0	4.0	4.0	4.0	4.0	4.0
<b>dn2</b>	Activation differential 2 in energy saving mode. (only if <b>rE</b> ≠ <b>0</b> )	°C/°F	-58.0...302	4.0	4.0	4.0	4.0	4.0	4.0	4.0	4.0
<b>EdH</b>	Start time hours weekday Energy Saving. <b>0 ... 23</b> = start hour; <b>24</b> = disabled.	hours	0 ... 24	21	21	21	21	21	24	21	21
<b>EEdn</b>	Workday Energy Saving start minutes.	min	0 ... 59	0	0	0	0	0	0	0	0
<b>EEd</b>	Duration of workday Energy Saving.	hours	1 ... 72	10	10	10	10	10	1	10	10
<b>EFH</b>	Holiday Energy Saving start hour. <b>0 ... 23</b> = start hour; <b>24</b> = disabled.	hours	0 ... 24	0	0	0	0	0	24	0	0
<b>EFn</b>	Holiday Energy Saving start minutes.	min	0 ... 59	0	0	0	0	0	0	0	0
<b>EFd</b>	Duration of holiday Energy Saving.	hours	1 ... 72	24	24	24	24	24	1	24	24
<b>FRAME HEATER parameters (FrH)</b>											
<b>FH</b>	Selects which probe will be used by frame heaters. <b>diS</b> (0) = disabled <b>dc</b> (1) = working in Duty Cycle <b>Pb1</b> (2) = will use probe Pb1 <b>Pb2</b> (3) = will use probe Pb2 <b>Pb3</b> (4) = will use probe Pb3 <b>Pb4</b> (5) = will use probe Pb4 <b>Pb5</b> (6) = will use probe Pb5 <b>Pbi</b> (7) = will use the virtual probe	num	diS dc Pb1 Pb2 Pb3 Pb4 Pb5 Pbi	dc	dc	dc	dc	dc	diS	dc	Pb4
<b>FHt</b>	Frame heater running time. <b>N.B.</b> = only used if output <b>OC</b> used with SSR relay.	sec*10	1 ... 250	30	30	30	30	30	1	30	30
<b>FHO</b>	Configuration of relative setpoint for frame heater (only if <b>FH</b> ≠ <b>dis</b> and <b>FH</b> ≠ <b>dc</b> ).	°C/°F	-58.0...302	0.0	0.0	0.0	0.0	0.0	0.0	0.0	0.0
<b>FH1</b>	Configuration of relative offset for frame heater (only if <b>FH</b> ≠ <b>dis</b> and <b>FH</b> ≠ <b>dc</b> ).	°C/°F	0.0 ... 25.0	0.0	0.0	0.0	0.0	0.0	0.0	0.0	10.0
<b>FH2</b>	Configuration of relative band for frame heater (only if <b>FH</b> ≠ <b>dis</b> and <b>FH</b> ≠ <b>dc</b> ).	°C/°F	0.0 ... 25.0	0.0	0.0	0.0	0.0	0.0	0.0	0.0	10.0
<b>FH3</b>	Configuration of minimum percentage for frame heater (only if <b>FH</b> ≠ <b>dis</b> and <b>FH</b> ≠ <b>dc</b> ).	%	0 ... 100	0	0	0	0	0	0	0	20
<b>FH4</b>	Sets maximum percentage for day Duty Cycle.	%	0 ... 100	75	75	75	75	75	0	75	100
<b>FH5</b>	Set maximum Percentage of the night Duty Cycle.	%	0 ... 100	50	50	50	50	50	0	50	80
<b>FH6</b>	Sets percentage during defrost.	%	0 ... 100	100	100	100	100	100	0	100	100
<b>COMMUNICATION parameters (Add)</b>											
<b>PtS</b>	Protocol selection. <b>t</b> (0) = Televis <b>d</b> (1) = ModBus	flag	t p	<b>t (Parameter not present in vectors)</b>							
<b>dEA</b>	Device address: indicates the device address to the management protocol.	num	0 ... 14	<b>0 (Parameter not present in vectors)</b>							
<b>FAA</b>	Family address: indicates the device family to the management protocol.	num	0 ... 14	<b>0 (Parameter not present in vectors)</b>							
<b>Adr</b>	Modbus protocol controller address (only if <b>PtS</b> = <b>d</b> ).	num	1 ... 250	<b>1 (Parameter not present in vectors)</b>							



Param.	DESCRIPTION	UM	RANGE	AP1	AP2	AP3	AP4	AP5	AP6	AP7	AP8
<b>bAU</b>	Baudrate selection. <b>96</b> (0) = 9600 <b>192</b> (1) = 19200 <b>384</b> (2) = 38400	num	96 192 384	<b>96 (Parameter not present in vectors)</b>							
<b>Pty</b>	Sets Modbus parity bit (only if <b>PtS = d</b> ). <b>n</b> (0) = none <b>E</b> (1) = even <b>o</b> (2) = odd	num	n E o	<b>n (Parameter not present in vectors)</b>							
<b>DISPLAY parameters (diS)</b>											
<b>LOC</b>	LOCK. Setpoint edit lock. You can still access the parameter programming menu and edit the parameters, including this parameter, in order to allow keypad unlocking. <b>no</b> (0) = no <b>yES</b> (1) = yes.	flag	no yES	no	no	no	no	no	no	no	no
<b>PS1</b>	PAssword 1. When enabled ( <b>PS1 ≠ 0</b> ) this is the access key to level 1 parameters ( <b>User</b> ).	num	0 ... 250	0	0	0	0	0	0	0	0
<b>PS2</b>	PAssword 2. When enabled ( <b>PS2 ≠ 0</b> ) this is the access key to level 2 parameters ( <b>Installer</b> ).	num	0 ... 250	15	15	15	15	15	15	15	15
<b>ndt</b>	Display with decimal point. <b>no</b> (0) = no (integers only) <b>yES</b> (1) = yes (decimal display).	flag	no yES	yES	yES	yES	yES	yES	yES	yES	yES
<b>CA1</b>	Probe <b>Pb1</b> calibration. Positive or negative temperature value added to the value read by <b>Pb1</b> . This sum is used both for the temperature displayed and for regulation.	°C/°F	-30.0...30.0	0.0	0.0	0.0	0.0	0.0	0.0	0.0	0.0
<b>CA2</b>	Probe <b>Pb2</b> calibration. Positive or negative temperature value added to the value read by <b>Pb2</b> . This sum is used both for the temperature displayed and for regulation.	°C/°F	-30.0...30.0	0.0	0.0	0.0	0.0	0.0	0.0	0.0	0.0
<b>CA3</b>	Probe <b>Pb3</b> calibration. Positive or negative temperature value added to the value read by <b>Pb3</b> . This sum is used both for the temperature displayed and for regulation.	°C/°F	-30.0...30.0	0.0	0.0	0.0	0.0	0.0	0.0	0.0	0.0
<b>CA4</b>	Probe <b>Pb4</b> calibration. Positive or negative temperature value added to the value read by <b>Pb4</b> . This sum is used both for the temperature displayed and for regulation.	°C/°F	-30.0...30.0	0.0	0.0	0.0	0.0	0.0	0.0	0.0	0.0
<b>CA5</b>	Probe <b>Pb5</b> calibration. Positive or negative temperature value added to the value read by <b>Pb5</b> . This sum is used both for the temperature displayed and for regulation.	°C/°F	-30.0...30.0	0.0	0.0	0.0	0.0	0.0	0.0	0.0	0.0
<b>LdL</b>	Minimum value that can be displayed by the device.	°C/°F	-58.0...HdL	-40.0	-40.0	-40.0	-40.0	-40.0	-40.0	-40.0	-40.0
<b>HdL</b>	Maximum value that can be displayed by the device.	°C/°F	LdL...302	20.0	20.0	20.0	20.0	20.0	20.0	20.0	20.0
<b>ddl</b>	Display mode during defrost. <b>0</b> = displays the temperature read by probe <b>1</b> = blocks the reading at the temperature value read by the probe when defrosting starts and until the next time the SET is reached. <b>2</b> = displays label <b>def</b> during defrost and until the SET is reached (or until <b>Ldd</b> elapses).	num	0/1/2	0	0	0	0	0	0	0	0
<b>Ldd</b>	Timeout value for display unlock - label <b>def</b> .	min	0 ... 250	0	0	0	0	0	0	0	0
<b>dro</b>	Selection of °C or °F to display the probe value. <b>C</b> (0) = °C, <b>F</b> (1) = °F. <b>NOTE: switching between °C and °F or vice versa DOES NOT modify setpoints, differentials, etc. (example: set=10°C becomes 10°F).</b>	flag	C F	C	C	C	C	C	C	C	C
<b>ddd</b>	Selects type of value to display. <b>SP1</b> (0) = setpoint <b>Pb1</b> (1) = will use probe Pb1 <b>Pb2</b> (2) = will use probe Pb2 <b>Pb3</b> (3) = will use probe Pb3 <b>Pb4</b> (4) = will use probe Pb4 <b>Pb5</b> (5) = will use probe Pb5 <b>Pbi</b> (6) = will use the virtual probe <b>LP</b> (7) = will use the probe of the LINK <sup>2</sup> network	num	SP1 Pb1 Pb2 Pb3 Pb4 Pb5 Pbi LP	Pbi	Pb1	Pb1	Pb1	Pb1	Pb1	Pb1	Pb1



Param.	DESCRIPTION	UM	RANGE	AP1	AP2	AP3	AP4	AP5	AP6	AP7	AP8
<b>dde</b>	Select the type of value to show on ECHO module display. Same as <b>ddd</b> .	num	SP1, Pb1 ... Pb5, Pbi, LP	SP1	SP1	SP1	SP1	SP1	SP1	SP1	SP1
<b>HACCP parameters (HCP)</b>											
<b>rPH</b>	Selects which probe will be used by the HACCP alarms. <b>diS</b> (0) = disabled <b>Pb1</b> (1) = will use probe Pb1 <b>Pb2</b> (2) = will use probe Pb2 <b>Pb3</b> (3) = will use probe Pb3 <b>Pb4</b> (4) = will use probe Pb4 <b>Pb5</b> (5) = will use probe Pb5	num	diS Pb1 Pb2 Pb3 Pb4 Pb5	diS	diS	diS	diS	diS	diS	diS	diS
<b>CONFIGURATION (CnF)</b> ➔ If one or more of the parameters in the folder are changed, the controller <b>MUST</b> be switched off and on again.											
<b>H00</b>	Select type of probe used (Pb1 ... Pb5). <b>ntc</b> (0) = NTC <b>Ptc</b> (1) = PTC <b>Pt1</b> (2) = PT1000	num	ntc Ptc Pt1	ntc	ntc	ntc	ntc	ntc	ntc	ntc	ntc
<b>H02</b>	Key activation time, when configured with a second function. When the <b>ESC</b> , <b>UP</b> and <b>DOWN</b> keys have been configured with a second function (defrost, AUX, etc.), a time is set for quick activation. AUX and LIGHT functions are an exception to this, having a fixed delay of 0.5 seconds.	num	0 ... 250	5	5	5	5	5	5	5	5
<b>H08</b>	Function when in standby mode. <b>0</b> = display off; the regulators are active and the device reactivates the display to signal any alarms. <b>1</b> = display off; regulators and alarms blocked. <b>2</b> = display shows OFF label; regulators and alarms blocked.	num	0/1/2	2	2	2	2	2	2	2	2
<b>H11</b>	Configuration of digital input 1/polarity (PB1). <b>0</b> = disabled <b>± 1</b> = start defrost <b>± 2</b> = end defrost <b>± 3</b> = Light <b>± 4</b> = Energy Saving <b>± 5</b> = AUX <b>± 6</b> = external alarm <b>± 7</b> = Stand-by <b>± 8</b> = door switch <b>± 9</b> = preheating alarm <b>± 10</b> = general pressure switch <b>± 11</b> = low pressure switch <b>± 12</b> = high general pressure switch <b>± 13</b> = deep cooling <b>± 14</b> = not used <b>± 15</b> = force Fans to ON <b>± 16</b> = force OF1 (remote offset) <b>± 17</b> = general input. <b>NOTE:</b> - The "+" sign indicates that the input is active when the contact is closed. - The "-" sign indicates that the input is active when the contact is open.	num	-17 ... 17	0	0	0	0	0	0	0	0
<b>H12</b>	Configuration of digital input 2/polarity (PB2). Same as <b>H11</b> .	num	-17 ... 17	0	0	0	0	0	0	0	0
<b>H13</b>	Configuration of digital input 3/polarity (PB3). Same as <b>H11</b> .	num	-17 ... 17	0	0	0	0	0	0	0	0
<b>H14</b>	Configuration of digital input 4/polarity (PB4). Same as <b>H11</b> .	num	-17 ... 17	0	0	0	0	0	0	0	0
<b>H15</b>	Configuration of digital input 5/polarity (PB5). Same as <b>H11</b> .	num	-17 ... 17	0	0	0	0	0	0	0	0
<b>H16</b>	Configuration of digital input 6/polarity (DI2). Same as <b>H11</b> .	num	-17 ... 17	0	0	0	0	0	0	0	0
<b>H17</b>	Configuration of digital input 7/polarity (DI3). Same as <b>H11</b> .	num	-17 ... 17	0	0	0	0	0	0	0	0
<b>H18</b>	Configuration of digital input 8/polarity (DI1). Same as <b>H11</b> .	num	-17 ... 17	0	8	0	0	0	8	0	8
<b>dti</b>	Unit of measure for digital inputs DI1 and DI2. If DI1 or DI2 have been configured as DI, the unit of measure used can be set. <b>0</b> = minutes <b>1</b> = seconds.	num	0/1	0	0	0	0	0	0	0	0
<b>d11</b>	Delay to activate digital input 1 (PB1).	min/sec	0 ... 255	0	0	0	0	0	0	0	0



Param.	DESCRIPTION	UM	RANGE	AP1	AP2	AP3	AP4	AP5	AP6	AP7	AP8
<b>d12</b>	Delay to activate digital input 2 (PB2).	min/sec	0 ... 255	0	0	0	0	0	0	0	0
<b>d13</b>	Delay to activate digital input 3 (PB3).	min	0 ... 255	0	0	0	0	0	0	0	0
<b>d14</b>	Delay to activate digital input 4 (PB4).	min	0 ... 255	0	0	0	0	0	0	0	0
<b>d15</b>	Delay to activate digital input 5 (PB5).	min	0 ... 255	0	0	0	0	0	0	0	0
<b>d16</b>	Delay to activate digital input 6 (DI2).	min	0 ... 255	0	0	0	0	0	0	0	0
<b>d17</b>	Delay to activate digital input 7 (DI3).	min	0 ... 255	0	0	0	0	0	0	0	0
<b>d18</b>	Delay to activate digital input 8 (DI1).	min	0 ... 255	0	0	0	0	0	0	0	0
<b>H21</b>	Configuration of digital output 4 (OUT 4). <b>0</b> = disabled <b>1</b> = compressor 1 <b>2</b> = defrost 1 / hot gas valve <b>3</b> = evaporator fans <b>4</b> = alarm <b>5</b> = AUX <b>6</b> = Stand-by <b>7</b> = Light <b>8</b> = frame heater <b>9</b> = defrost 2 <b>10</b> = compressor 2; <b>11</b> = not used <b>12</b> = AUX regulator <b>13</b> = hot gas on evaporation suction valve	num	0 ... 13	1	1	1	1	1	1	1	1
<b>H22</b>	Configuration of digital output 2 (OUT 2). Same as <b>H21</b> .	num	0 ... 13	3	3	3	3	3	3	3	3
<b>H23</b>	Configuration of digital output 3 (OUT 3). Same as <b>H21</b> .	num	0 ... 13	2	2	2	2	2	2	2	2
<b>H24</b>	Configuration of digital output 4 (OUT 4). Same as <b>H21</b> .	num	0 ... 13	5	4	4	4	4	4	4	4
<b>H25</b>	Configuration of digital output 5 (OUT 5). Same as <b>H21</b> .	num	0 ... 13	7	7	7	7	7	7	7	7
<b>H26</b>	Configuration of digital output 6 (OUT 6). Same as <b>H21</b> .	num	0 ... 13	4	0	0	0	0	0	13	0
<b>H27</b>	Configuration of digital output 7 (Open Collector - OC). Same as <b>H21</b> .	num	0 ... 13	8	8	8	8	8	0	8	0
<b>H29</b>	Enables keypad buzzer. <b>diS</b> (0) = output disabled <b>En</b> (1) = output enabled	flag	diS EN	diS	diS	diS	diS	diS	diS	diS	diS
<b>H31</b>	UP key configuration. <b>0</b> = Disabled <b>1</b> = Defrost <b>2</b> = Reduced setpoint <b>3</b> = Light <b>4</b> = Energy saving <b>5</b> = AUX <b>6</b> = Stand-by <b>7</b> = Deep cooling <b>8</b> = Start/stop defrost.	num	0 ... 8	1	1	1	1	1	1	1	1
<b>H32</b>	DOWN key configuration. Same as <b>H31</b> .	num	0 ... 8	0	0	0	0	0	0	0	0
<b>H33</b>	ESC key configuration. Same as <b>H31</b> .	num	0 ... 8	6	6	6	6	6	6	6	6
<b>H41</b>	Configuration of analogue input type 1 (Pb1). <b>diS</b> (0) = disabled <b>di</b> (1) = digital input <b>Pro</b> (2) = probe input.	num	diS of Pro	Pro	Pro	Pro	Pro	Pro	Pro	Pro	Pro
<b>H42</b>	Configuration of analogue input type 2 (Pb2). Same as <b>H41</b> .	num	diS/di/Pro	Pro	diS	diS	diS	Pro	diS	diS	diS
<b>H43</b>	Configuration of analogue input type 3 (Pb3). Same as <b>H41</b> .	num	diS/di/Pro	Pro	Pro	Pro	Pro	Pro	Pro	Pro	Pro
<b>H44</b>	Configuration of analogue input type 4 (Pb4). Same as <b>H41</b> .	num	diS/di/Pro	diS	diS	diS	diS	diS	diS	diS	Pro
<b>H45</b>	Configuration of analogue input type 5 (Pb5). Same as <b>H41</b> .	num	diS/di/Pro	of	of	of	of	of	of	of	of
<b>H50</b>	Configuration of analogue output type. <b>010</b> (0) = output 0-10V <b>420</b> (1) = output 4-20mA	flag	010 420	010	010	010	010	010	010	010	010
<b>H51</b>	Regulator associated to analogue output <b>diS</b> (0) = disabled <b>FH</b> (1) = Frame Heater	flag	diS FH	diS	diS	diS	diS	diS	diS	diS	FH



Param.	DESCRIPTION	UM	RANGE	AP1	AP2	AP3	AP4	AP5	AP6	AP7	AP8
<b>H60</b>	Display of selected application. <b>0</b> = disabled <b>1</b> = Vector 1 (AP1) <b>2</b> = Vector 2 (AP2) <b>3</b> = Vector 3 (AP3) <b>4</b> = Vector 4 (AP4) <b>5</b> = Vector 5 (AP5) <b>6</b> = Vector 6 (AP6) <b>7</b> = Vector 7 (AP7) <b>8</b> = Vector 8 (AP8)	num	0 ... 8	<b>1 (Parameter not present in vectors)</b>							
<b>H68</b>	Clock Present <b>no</b> (0) = clock absent <b>yES</b> (1) = clock present.	flag	no yES	yES	yES	yES	yES	yES	yES	yES	yES
<b>H70</b>	Select 1st probe to use as virtual probe. <b>diS</b> (0) = disabled <b>Pb1</b> (1) = will use probe Pb1 <b>Pb2</b> (2) = will use probe Pb2 <b>Pb3</b> (3) = will use probe Pb3 <b>Pb4</b> (4) = will use probe Pb4 <b>Pb5</b> (5) = will use probe Pb5	num	diS Pb1 Pb2 Pb3 Pb4 Pb5	Pb1	diS	diS	diS	diS	diS	diS	diS
<b>H71</b>	Select 2nd probe to use as virtual probe. Same as <b>H70</b> .	num	0 ... 5	Pb2	diS	diS	diS	diS	diS	diS	diS
<b>H72</b>	% calculation used by day virtual probe	%	0 ... 100	50	0	0	0	0	0	0	0
<b>H73</b>	% calculation used by virtual probe at night (Energy Saving mode).	%	0 ... 100	50	0	0	0	0	0	0	0
<b>COPY CARD parameters (FPr)</b>											
<b>UL</b>	Upload. Transfer programming parameters from instrument to Copy Card.	/	/	<b>/ (Parameter not present in vectors)</b>							
<b>dL</b>	Download. Transfer programming parameters from Copy Card to Controller.	/	/	<b>/ (Parameter not present in vectors)</b>							
<b>Fr</b>	Formatting. Delete data on Copy Card. <b>IMPORTANT: if parameter "Fr" is used, the data entered will be permanently lost. This operation cannot be reversed.</b>	/	/	<b>/ (Parameter not present in vectors)</b>							

**FUNCTION parameters (FnC)**

The following functions are available:

Function	Function label ACTIVE	Function label not active	Alarm signaling
Manual defrost	dEF + LED blinking	dEF	Blinking Defrost icon
AUX (ON = on; OFF = off)	Aon	AoF	AUX ON icon
Reset pressure switch alarms	rAP	rAP	Alarm ON icon
Stand-by	OFF	OFF	Stand-by ON Led (KDWPlus only)

- NOTES:
- To modify the status of a given function, press the 'set' key
  - If the instrument is switched off, the function labels will return to the default status.



### 7.1 - ALARM AND MESSAGES TABLE

When an alarm condition is detected, the alarm icon “(●)” will come on.

If present and enabled, the buzzer and alarm relay will also activate.

To silence the buzzer, press and release any key, the relative icon will continue to flash.

All alarms reset automatically (i.e. disappear when the underlying cause is removed).

The alarm codes are as follows:

Code	Description	LED (●)	Relay temperature alarm	Reset	Parameters involved to ENABLE ALARM
E1	Probe Pb1 failure	ON	Active	Automatic	Ont, OFt
E2	Probe Pb2 failure	ON	Active	Automatic	Ont, OFt
E3	Probe Pb3 failure	ON	Active	Automatic	Ont, OFt
E4	Probe Pb4 failure	ON	Active	Automatic	Ont, OFt
E5	Probe Pb5 failure	ON	Active	Automatic	Ont, OFt
EL	LINK <sup>2</sup> probe failure	ON	Active	Automatic	Ont, OFt
Ei	Virtual probe failure	ON	Active	Automatic	Ont, OFt
AH1	HIGH temperature 1 alarm	ON	Active	Automatic	SP1, Att, AFd, HA1, LA1, PAO, dAO, OAO, tA1
AL1	LOW temperature 1 alarm	ON	Active	Automatic	SP1, Att, AFd, HA1, LA1, PAO, dAO, OAO, tA1
AH2	HIGH temperature 2 alarm	ON	Active	Automatic	SP2, Att, AFd, HA2, LA2, PAO, dAO, OAO, tA2
AL2	LOW temperature 2 alarm	ON	Active	Automatic	SP2, Att, AFd, HA2, LA2, PAO, dAO, OAO, tA2
EA	External alarm	ON	Active	Automatic	PEA, EAL
OPd	Door open alarm	ON	not active	Automatic	PEA, tdO
Ad2	End of defrost due to time-out	ON	not active	Automatic	dE1, dE2, dAt
Prr	Preheating alarm	ON	not active	Automatic	
E10	Clock alarm	ON	not active	Automatic	
nPA	General pressure switch alarm	ON	not active	Automatic	PEn, PEi
PA	General pressure switch alarm	ON	not active	Manual	PEn, PEi
LPA	Low pressure switch alarm	ON	not active	Automatic	PEn, PEi
PA	Low pressure switch alarm	ON	not active	Manual	PEn, PEi
HPA	High pressure switch alarm	ON	not active	Automatic	PEn, PEi
PA	High pressure switch alarm	ON	not active	Manual	PEn, PEi

**NOTE:**

- 1) If alarm exclusion times have been applied (“AL” folder in Parameter Table), the alarm will not be signaled.
- 2) With the exception of probe failure alarms, all other alarms will record the relative label in the ALr folder in the MACHINE STATE menu.
- 3) Alarms deriving from a probe failure will be shown on the display via label E1, E2, E3, E4, E5, EL and Ei depending on whether it relates to probe Pb1, Pb2, Pb3, Pb4, Pb5, LINK<sup>2</sup> or Virtual probe.



## 7.1.1 - CAUSE/EFFECT TABLE

The RTX600/V can run full system diagnostics and signal any operating anomalies with specific alarms as well as record and signal on the display any special events defined by the user, to provide greater system control.

Label	Fault	Cause	Effects	Remedy
<b>E1</b>	Probe Pb1 faulty	<ul style="list-style-type: none"> <li>Measured values are outside operating range</li> <li>probe faulty/short-circuited/open</li> </ul>	<ul style="list-style-type: none"> <li>Label <b>E1 displayed</b>.</li> <li>Alarm icon permanently on</li> </ul>	<ul style="list-style-type: none"> <li>Check probe type (<b>H00</b>)</li> <li>Check the probe wiring</li> <li>Replace probe</li> </ul>
<b>E2</b>	Probe Pb2 faulty	<ul style="list-style-type: none"> <li>Measured values are outside operating range</li> <li>probe faulty/short-circuited/open</li> </ul>	<ul style="list-style-type: none"> <li>Label <b>E2 displayed</b>.</li> <li>Alarm icon permanently on</li> </ul>	<ul style="list-style-type: none"> <li>Check probe type (<b>H00</b>)</li> <li>Check the probe wiring</li> <li>Replace probe</li> </ul>
<b>E3</b>	Probe Pb3 faulty	<ul style="list-style-type: none"> <li>Measured values are outside operating range</li> <li>probe faulty/short-circuited/open</li> </ul>	<ul style="list-style-type: none"> <li>Label <b>E3 displayed</b>.</li> <li>Alarm icon permanently on</li> </ul>	<ul style="list-style-type: none"> <li>Check probe type (<b>H00</b>)</li> <li>Check the probe wiring</li> <li>Replace probe</li> </ul>
<b>E4</b>	Probe Pb4 faulty	<ul style="list-style-type: none"> <li>Measured values are outside operating range</li> <li>probe faulty/short-circuited/open</li> </ul>	<ul style="list-style-type: none"> <li>Label <b>E4 displayed</b></li> <li>Alarm icon permanently on</li> </ul>	<ul style="list-style-type: none"> <li>Check probe type (<b>H00</b>)</li> <li>Check the probe wiring</li> <li>Replace probe</li> </ul>
<b>E5</b>	Probe Pb5 faulty	<ul style="list-style-type: none"> <li>Measured values are outside operating range</li> <li>probe faulty/short-circuited/open</li> </ul>	<ul style="list-style-type: none"> <li>Label <b>E5 displayed</b></li> <li>Alarm icon permanently on</li> </ul>	<ul style="list-style-type: none"> <li>Check probe type (<b>H00</b>)</li> <li>Check the probe wiring</li> <li>Replace probe</li> </ul>
<b>EL</b>	LINK <sup>2</sup> probe faulty	<ul style="list-style-type: none"> <li>Measured values are outside operating range</li> <li>probe faulty/short-circuited/open</li> </ul>	<ul style="list-style-type: none"> <li>Label <b>EL displayed</b></li> <li>Alarm icon permanently on</li> </ul>	<ul style="list-style-type: none"> <li>Check the probe type</li> <li>Check the probe wiring</li> <li>Replace probe</li> </ul>
<b>Ei</b>	VIRTUAL probe faulty	<ul style="list-style-type: none"> <li>Measured values are outside operating range</li> <li>probe faulty/short-circuited/open</li> </ul>	<ul style="list-style-type: none"> <li>Label <b>Ei displayed</b>.</li> <li>Alarm icon permanently on</li> </ul>	<ul style="list-style-type: none"> <li>Check the probe type</li> <li>Check the probe wiring</li> <li>Replace probe</li> </ul>
<b>AH1</b>	HIGH temperature alarm 1	value read by probe 1 > HA1 after time set in tA1. (see "MAX/MIN TEMP. ALARMS")	<ul style="list-style-type: none"> <li>Label <b>AH1</b> recorded in folder ALr</li> <li>No effect on control</li> </ul>	Wait until value read by probe selected with <b>rA1</b> returns below ( <b>HA1-AFd</b> ).
<b>AL1</b>	LOW temperature alarm 1	value read by probe 1 > LA1 after time set in tA1. (see "MAX/MIN TEMP. ALARMS")	<ul style="list-style-type: none"> <li>Label <b>AL1</b> recorded in folder ALr</li> <li>No effect on control</li> </ul>	Wait until value read by probe selected with <b>rA1</b> returns above ( <b>LA1+Afd</b> ).
<b>AH2</b>	HIGH temperature alarm 2	value read by probe 2 > HA2 after time set in tA2. (see "MAX/MIN TEMP. ALARMS")	<ul style="list-style-type: none"> <li>Label <b>AH2</b> recorded in folder ALr</li> <li>No effect on control</li> </ul>	Wait until value read by probe selected with <b>rA2</b> returns below ( <b>HA2-AFd</b> ).
<b>AL2</b>	LOW temperature alarm 2	value read by probe 2 > LA2 after time set in tA2. (see "MAX/MIN TEMP. ALARMS")	<ul style="list-style-type: none"> <li>Label <b>AL2</b> recorded in folder ALr</li> <li>No effect on control</li> </ul>	Wait until value read by probe selected with <b>rA2</b> returns above ( <b>LA2+Afd</b> ).
<b>EA</b>	External alarm	Digital input activated	<ul style="list-style-type: none"> <li>Label <b>EA</b> recorded in folder ALr</li> <li>Alarm icon permanently on</li> <li>Regulation blocked as requested by <b>EAL</b></li> </ul>	Check and remove external cause of alarm on D.I.
<b>OPd</b>	Door open alarm	Digital input activated (for a time greater than tdO)	<ul style="list-style-type: none"> <li>Label <b>OPd</b> recorded in folder ALr</li> <li>Alarm icon permanently on</li> <li>Regulation blocked as requested by <b>dOd</b></li> </ul>	<ul style="list-style-type: none"> <li>Close the door</li> <li>Delay function defined by <b>OAO</b></li> </ul>
<b>Ad2</b>	End defrost by time-out	End of defrost cycle due to timeout rather than due to defrost end temperature being read by Pb2.	<ul style="list-style-type: none"> <li>Label <b>Ad2</b> recorded in folder ALr</li> <li>Alarm icon permanently on</li> </ul>	Wait for the next defrost cycle for automatic reset.
<b>Prr</b>	Preheat alarm	Alarm for preheat input regulator ON	<ul style="list-style-type: none"> <li>Label <b>Prr displayed</b>.</li> <li>Compressor icon blinking</li> <li>Regulation locked (Compressor and Fans)</li> </ul> <p><b>NOTE:</b> defrost will also be blocked if it is hot gas defrost.</p>	Preheat input regulator off
<b>E10</b>	Clock alarm	<ul style="list-style-type: none"> <li>Clock (RTC) battery dead.</li> <li>RTC failure.</li> </ul>	<ul style="list-style-type: none"> <li>Label <b>E10</b> recorded in folder ALr</li> <li>Functions associated with clock not available</li> </ul>	Connect the instrument to the power supply.





Label	Fault	Cause	Effects	Remedy
<b>nPA</b>	General pressure switch alarm	Activation of pressure switch alarm by general pressure switch regulator.	If the number <b>N</b> of pressure switch activations is $N < PEn$ <ul style="list-style-type: none"> <li>Folder <b>nPA</b> recorded in folder ALr with the number of pressure switch activations</li> <li>Regulation locked (Compressor and Fans)</li> </ul>	Check and remove cause of alarm on D.I. (Auto Reset).
<b>PA</b>	General pressure switch alarm	Activation of pressure switch alarm by general pressure switch regulator.	If the number <b>N</b> of pressure switch activations is $N = PEn$ : <ul style="list-style-type: none"> <li>Label <b>PA displayed.</b></li> <li>Label <b>PA</b> recorded in folder ALr</li> <li>Alarm icon permanently on</li> <li>Regulation locked (Compressor and Fans)</li> </ul>	<ul style="list-style-type: none"> <li>Switch the device off and back on again</li> <li>Reset alarms by entering the functions folder and selecting the <b>rAP</b> function (Manual Reset)</li> </ul>
<b>LPA</b>	Low pressure switch alarm	Activation of pressure switch alarm by low pressure switch regulator.	If the number <b>N</b> of pressure switch activations is $N < PEn$ : <ul style="list-style-type: none"> <li>Folder <b>LPA</b> recorded in folder ALr with the number of pressure switch activations</li> <li>Regulation locked (Compressor and Fans)</li> </ul>	Check and remove cause of alarm on D.I. (Auto Reset).
<b>PA</b>	Low pressure switch alarm	Activation of pressure switch alarm by low pressure switch regulator.	If the number <b>N</b> of pressure switch activations is $N = PEn$ : <ul style="list-style-type: none"> <li>Label <b>PAL displayed</b></li> <li>Label <b>PA</b> recorded in folder ALr</li> <li>Alarm icon permanently on</li> <li>Regulation locked (Compressor and Fans)</li> </ul>	<ul style="list-style-type: none"> <li>Switch the device off and back on again</li> <li>Reset alarms by entering the functions folder and selecting the <b>therAP</b> function (Manual Reset)</li> </ul>
<b>HPA</b>	High pressure switch alarm	Activation of pressure switch alarm by high pressure switch regulator.	If the number <b>N</b> of pressure switch activations is $N < PEn$ : <ul style="list-style-type: none"> <li>Folder <b>HPA</b> recorded in folder ALr with the number of pressure switch activations</li> <li>Regulation locked (Compressor and Fans)</li> </ul>	Check and remove cause of alarm on D.I. (Auto Reset).
<b>PA</b>	High pressure switch alarm	Activation of pressure switch alarm by high pressure switch regulator.	If the number <b>N</b> of pressure switch activations is $N = PEn$ : <ul style="list-style-type: none"> <li>Label <b>PAH displayed.</b></li> <li>Label <b>PA</b> recorded in folder ALr</li> <li>Alarm icon permanently on</li> <li>Regulation locked (Compressor and Fans)</li> </ul>	<ul style="list-style-type: none"> <li>Switch the device off and back on again</li> <li>Reset alarms by entering the functions folder and selecting the <b>rAP</b> function (Manual Reset)</li> </ul>



## 7.2 - DESCRIPTION OF ALARMS

### 7.2.1 - PROBE ALARM

#### OPERATING CONDITIONS

When one of the probes is out of the nominal operating range or in the case of an open probe or a probe in short circuit, an alarm is generated if this condition persists for longer than 10 seconds.

The alarm condition is indicated on the display by means of the following error codes:

- **E1** = Probe Pb1 failure
- **E2** = Probe Pb2 failure
- **E3** = Probe Pb3 failure
- **E4** = Probe Pb4 failure
- **E5** = Probe Pb5 failure
- **EL** = LINK<sup>2</sup> probe failure
- **Ei** = VIRTUAL probe failure

The alarm LED and alarm relay are activated. Codes **E1**, **E2**, **E3**, **E4**, **E5**, **EL** and **Ei**, if they occur at the same time, are displayed in the following sequence: E1 x 2 sec, E2 x 2 sec, E3 x 2 sec, etc.

#### ACTIONS ON CURRENT REGULATION

For all probes, a probe error will cause the following actions:

- Code **E<sub>x</sub>** shown on display (where **x** = 1, 2, 3, 4, 5, 6, 7, L, i)
- Alarm icon permanently on and alarm relay activated (if present)

When the probe failure condition ceases, regulator resumes as normal.

During probe error, the defrost interval count continues as normal.

#### SIGNALLING

Code	Meaning
<b>E1</b>	Probe Pb1 error
<b>E2</b>	Probe Pb2 error
<b>E3</b>	Probe Pb3 error
<b>E4</b>	Probe Pb4 error.
<b>E5</b>	Probe Pb5 error.
<b>EL</b>	LINK <sup>2</sup> probe error
<b>Ei</b>	Virtual probe error.

#### ALARM ACKNOWLEDGEMENT

In the alarm condition, it is possible to acknowledge the alarm and/or relay configured as an alarm, even if the alarm condition persists, by pressing any key or using the corresponding function in the menu. The alarm LED will start to blink.

Eliminating the cause of the alarm disarms the acknowledgment.

The probe fault alarm is not stored by the controller.

#### USER PARAMETERS

Label	Description
<b>Ont</b>	ON time for compressor output with faulty regulation probe
<b>OFt</b>	OFF time for compressor output with faulty regulation probe



## 7.2.2 - MINIMUM AND MAXIMUM TEMPERATURE ALARM

### OPERATING CONDITIONS

Alarm regulation is based on probe 1. The temperature limits defined in parameters **HA1/2** and **LA1/2** are characterized by parameter **Att** which specifies if they represent the absolute temperature value or a differential from the setpoint (in the event of an offset from the setpoint entered, the high and low alarms will refer to this new regulation set).

- If **Att=0 Ab(solute)**, the temperature limits for probe 1/2 are absolute.
- If **Att=1 rE(lative)**, temperature limits for probe 1/2 refer to setpoints **SP1/2**.

 **N.B.:** to obtain the minimum alarm below the setpoint in the event **Att=1** (relative), **LA1/2** must be set to  $< 0$

### ALARM CONDITION

A maximum/minimum alarm is generated when the Pb1 temperature is:

- Maximum alarm:  $\geq \text{HA1/2}$  if **Att=Ab(solute)** and  $\geq \text{SP1/2} + \text{HA1/2}$  if **Att=rE(lative)**
- Minimum alarm:  $\leq \text{LA1/2}$  if **Att=Ab(solute)** and  $\leq \text{SP1/2} + \text{LA1/2}$  if **Att=rE(lative)**

If **Att = Ab(solute)**, **HA1/2** and **LA1/2** must have a sign, if **Att = rE(lative)** then **HA1/2 > 0** and **LA1/2 < 0**.

When one of the aforementioned conditions occurs and no alarm exclusion times have been set (see exclude alarm parameters), the alarm LED comes on and relay configured as alarm is activated (if present).

The maximum/minimum alarm ceases when the temperature of probe 1/2:

- After maximum alarm:  $\leq (\text{HA1/2} - \text{AFd})$  if **Att=Ab(solute)** and  $\leq (\text{Set} + \text{HA1/2} - \text{AFd})$  if **Att=rE(lative)**
- After minimum alarm:  $\geq (\text{LA1/2} + \text{AFd})$  if **Att=Ab(solute)** and  $\geq (\text{Set} + \text{LA1/2} + \text{AFd})$  if **Att=rE(lative)**

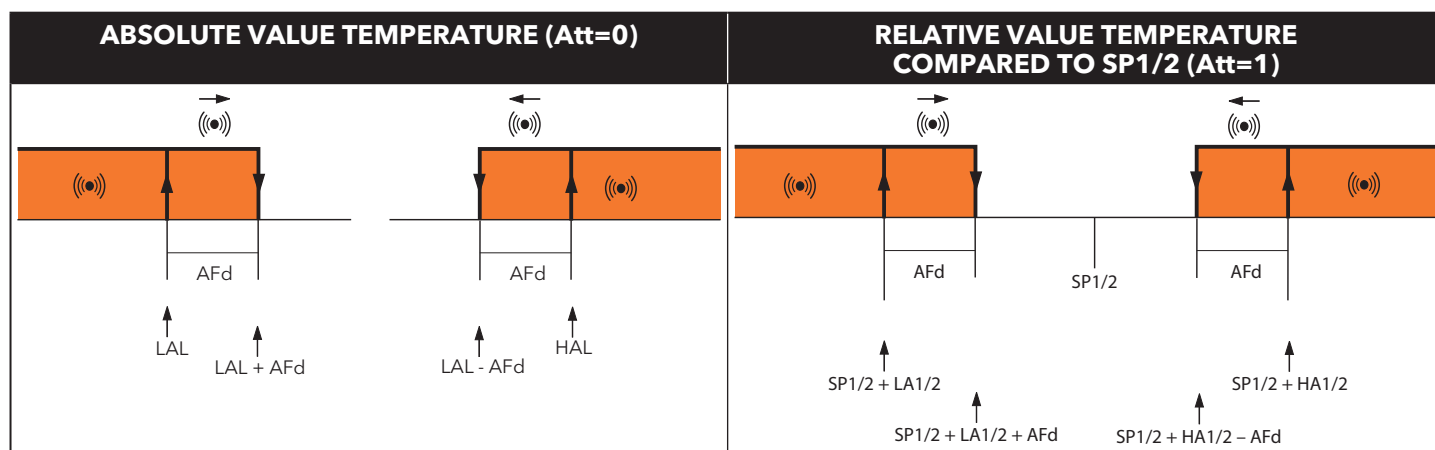

 **N.B.:**

- During a defrost cycle, high and low temperature alarms are overridden.
- Occurrence of this alarm does not effect any regulation in progress.

### SIGNALLING

Code	Meaning
<b>AH1/2</b>	HIGH temperature alarm in relation to probe 1/2
<b>AL1/2</b>	LOW temperature alarm in relation to probe 1/2

### ALARM ACKNOWLEDGEMENT

When an alarm has occurred, the relay configured as alarm (if present) can be overridden by pressing any key or via a menu function even if the alarm condition persists. The alarm LED will start to blink.

Eliminating the cause of the alarm disarms the acknowledgement.

The probe fault alarm is not stored by the controller.

### USER PARAMETERS

Label	Description
<b>Att</b>	HAL and LAL parameter mode (absolute or relative)
<b>AFd</b>	Alarm activation differential
<b>HA1</b>	Probe 1 maximum alarm threshold
<b>LA1</b>	Probe 1 minimum alarm threshold
<b>HA2</b>	Probe 1 maximum alarm threshold
<b>LA2</b>	Probe 1 minimum alarm threshold
<b>PAO</b>	Temperature alarms disabling time from power-on
<b>dAO</b>	Temperature alarm disabling time after defrost cycle
<b>OAO</b>	High and low temperature alarms disabling time after door closing
<b>tAO</b>	Temperature alarms delay time



## 7.2.3 - END OF DEFROST ALARM DUE TO TIME-OUT

### OPERATING CONDITIONS

The regulator is activated without any delay in the case of end of defrost due to timeout, instead of probe 2 reaching the defrost end temperature.

The action consists of:

- Permanent illumination of alarm LED
- Recording of label **Ad2** in the alarms menu

Automatic reset occurs with the start of the next defrost cycle.

The alarm LED can be switched off using the normal acknowledgment procedure, although the alarm signal is only actually canceled at the start of the next defrost cycle.

### SIGNALLING

Code	Meaning
<b>Ad2</b>	Defrost alarm on Pb2

### USER PARAMETERS

Label	Description
<b>dE1</b>	Evaporator 1 defrost time-out.
<b>dE2</b>	Evaporator 2 defrost time-out.
<b>dAt</b>	Alarm signaling end of defrost due to timeout

## 7.2.4 - EXTERNAL ALARM

### OPERATING CONDITIONS

In the case of activation of the digital input, the alarm regulator is activated with the delay set in parameter **dAd**, and this alarm persists until the next time the digital input is deactivated.

The action consist of:

- Permanent illumination of alarm LED
- Recording of label **EA** in the alarms menu
- Activation of the relay configured as alarm (if enabled)
- Regulation disabled if so configured in parameter **EAL**.

The alarm relay can be blocked but regulators remain blocked until the digital input is disabled.

Parameter **EAL** can have the following values:

- **EAL = 0**: no resources are blocked by an external alarm;
- **EAL = 1**: external alarm blocks compressor and defrost;
- **EAL = 2**: external alarm blocks compressor, defrost and fans.

### SIGNALLING

Code	Meaning
<b>EA</b>	External alarm

### USER PARAMETERS

Label	Description
<b>EAL</b>	External alarm blocks regulators



## 7.2.5 - DOOR OPEN ALARM

### OPERATING CONDITIONS

The door switch alarm is associated to a specially configured digital input:

- **H11, H12, H13, H14, H15, H16, H17 o H18 = ± 8**

On activation of the digital input (door open) and after delay **tdO** has elapsed, the door open alarm must be signaled in the alarms folder and the LED and alarm relay must light up. The label **OPd** is displayed.

The action consist of:

- Permanent illumination of alarm LED
- Recording of label **OPd** in the alarms menu
- Activation of the relay configured as alarm

As for other alarms, the relay can be disabled by pressing an override key; the alarm LED will blink and the label **OPd** will remain in the alarms menu until the door is closed.

If the door is opened, the regulator will act as configured in parameter **dOd**. The following values can occur:

- **dOd = 0**: no resources blocked
- **dOd = 1**: fans blocked
- **dOd = 2**: compressor blocked (COMPR)
- **dOd = 3**: both fans and compressor blocked.

If the door alarm blocks the compressor, it can be reactivated (even if the door remains open) by setting parameter **dCO**.

### SIGNALLING

Code	Meaning
<b>OPd</b>	Door open alarm

### USER PARAMETERS

Label	Description
<b>dOd</b>	Digital input for switching off utilities: <b>0</b> = disabled; <b>1</b> = disables fans; <b>2</b> = disables compressor; <b>3</b> = disables fans and compressor.
<b>dCO</b>	Compressor enabling delay from acknowledgement
<b>tdO</b>	Open door disabling time



## 7.2.6 - PRESSURE SWITCH INPUT ALARM

### OPERATING CONDITIONS

The pressure switch is associated to a specially configured digital input and be either general, low or high.



**N.B.:** The behaviour and configuration parameters are the same for all three types.

Each activation of the pressure switch input causes the immediate disabling of the compressor with a visual-only WARNING to signal the activation, brought about by the lighting up of the alarm LED and the display of a sub-folder named **nPA** (general), **LPA** (minimum) or **HPA** (maximum) in the alarms folder .

The number of pressure switch activations is stored in this folder.

If the pressure switch digital input is disabled, the compressor starts up again and the alarm LED switches off, but the alarms folder stores the number of activations recorded in the previous error count interval (set in the parameter PEi).

On reaching the number of activations set in parameter **PEn**, the number in the folder is replaced with the label **PA** and the letters **PA** (general), **PAL** (minimum) or **PAH** (maximum) appear on the display.

The compressor, fans and defrost are disabled and the alarm LED and alarm relay (if configured) are activated.

Once the controller is in alarm state, it must be powered off then on, or reset by activating the **rAP** (reset pressure switch alarm) function from the function menu



**N.B.:** the value **PEn** represents the number of pressure switch activations, in the interval set in the parameter PEi, which determines the entry into the alarm state and the disabling of the compressor, fans and defrost outputs. If **PEn = 0** the function is disabled and the pressure switch alarm is ignored.

### SIGNALLING

Code	Meaning
<b>nPA</b>	general pressure switch alarm
<b>LPA</b>	minimum pressure switch alarm
<b>HPA</b>	maximum pressure switch alarm

### USER PARAMETERS

Label	Description
<b>PEn</b>	Number of errors allowed per pressure switch input. <b>0</b> = disabled.
<b>PEi</b>	Pressure switch error count interval.

## 8 - MODBUS MSK 509 FUNCTIONS AND RESOURCES



Modbus is a client/server protocol for communication between devices connected in a network.

Modbus devices communicate using a master-slave technique in which only one device (master) can send messages.

The other devices in the network (slave) respond, returning the data requested by the master or executing the action contained in the message sent.

A slave is a device connected to a network that processes information and sends the results to the master using the Modbus protocol. The master device can send messages to individual slaves or to the entire network (broadcast) whilst slaves can only respond individually to the master.

The Modbus standard used by Eliwell employs the RTU code for data transmission.

### 8.1 - DATA FORMAT (RTU)

The coding model used defines the structure of messages transmitted on the network and the way in which this information is deciphered. The type of coding is usually selected on the basis of specific parameters (baud rate, parity, etc.); furthermore, some devices support only specific coding models, although it must be the same one for all devices connected in a Modbus network.

The protocol uses the RTU binary method with bytes configured as follows: **8 bits for data, non-parity bit (configurable), 2 stop bits.**

**NOTE: the transmission speed must be set at 9600 baud.**

Parameter setting allows the full configuration of the device

They can be modified using:

- Device keypad
- Copy Card
- Sending data via Modbus protocol directly to an individual controller or broadcasting it using the address 0.

#### 8.1.1 - NETWORK

The 2 connection diagrams for using Modbus are shown below:

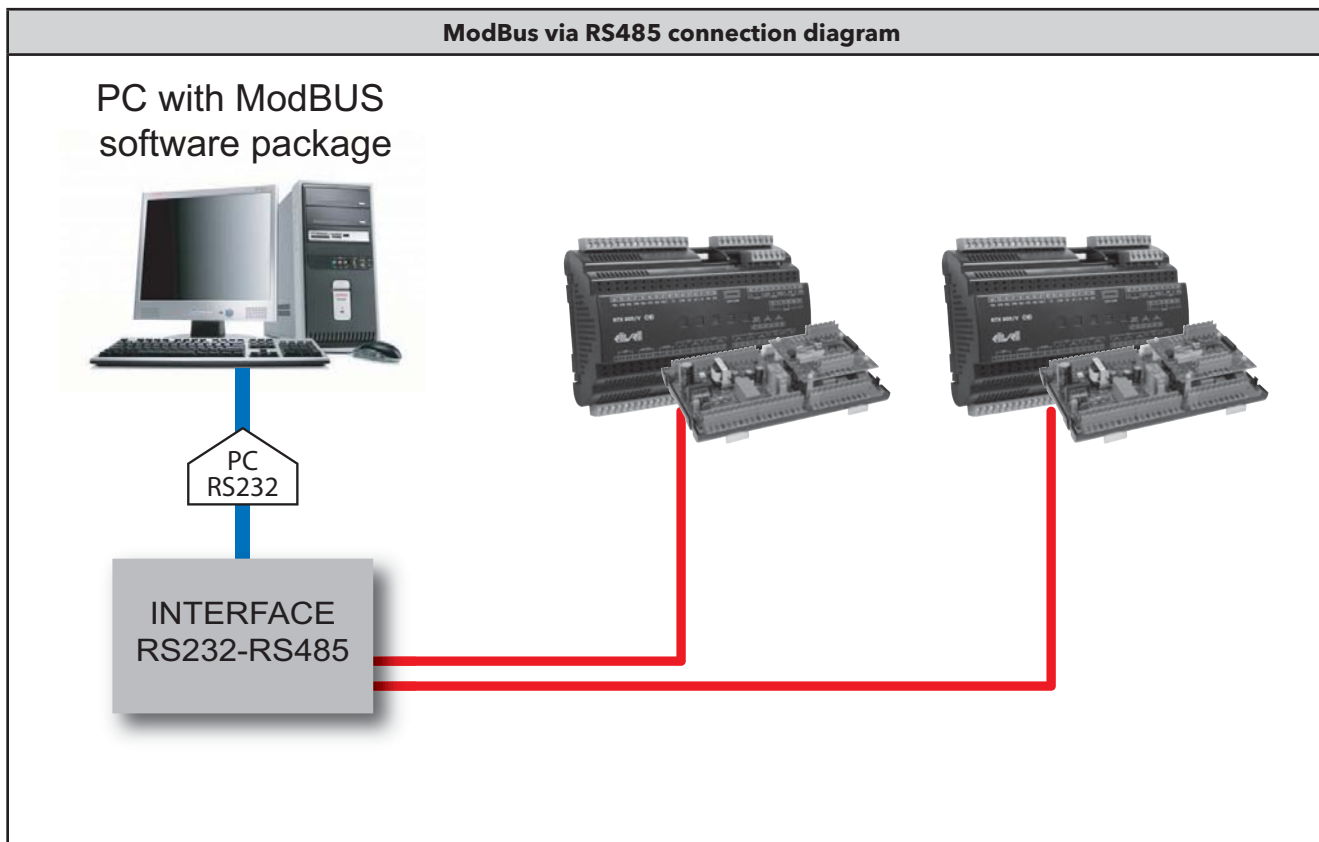



## 8.1.2 - MODBUS COMMANDS AVAILABLE AND DATA AREAS

The following commands are implemented:

Modbus command	Description of command								
<b>03</b> (hex 0x03)	Read 16 consecutive registers for Client side								
<b>04</b> (hex 0x04)	Read 1 single register for parameters								
<b>16</b> (hex 0x10)	Write 15 consecutive registers for Client side								
<b>22</b> (hex 0x16)	Write 1 register for the parameters								
<b>43</b> (hex 0x2B)	Read device ID It is possible to read the following 3 fields: <table border="1" data-bbox="625 651 1433 817"> <thead> <tr> <th>Field code</th> <th>Field description</th> </tr> </thead> <tbody> <tr> <td><b>0</b></td> <td>Manufacturer ID (=“Invensys”)</td> </tr> <tr> <td><b>1</b></td> <td>Device model/polycarbonate ID</td> </tr> <tr> <td><b>2</b></td> <td>Identification of device family (MSK 509)/version</td> </tr> </tbody> </table>	Field code	Field description	<b>0</b>	Manufacturer ID (=“Invensys”)	<b>1</b>	Device model/polycarbonate ID	<b>2</b>	Identification of device family (MSK 509)/version
Field code	Field description								
<b>0</b>	Manufacturer ID (=“Invensys”)								
<b>1</b>	Device model/polycarbonate ID								
<b>2</b>	Identification of device family (MSK 509)/version								

### Length restrictions

Maximum length in bytes of messages sent to device	30 BYTES
Maximum length in bytes of messages received by the device	30 BYTES

## 8.1.3 - ADDRESS CONFIGURATION

The serial TTL - which we will call COM1 - can be used to configure the device, parameters, states, and variables with Modbus via the Modbus protocol.

The address of a device in a ModBus message is set via parameter **Adr**.

The address 0 is used for broadcast messages that all slaves recognize. Slaves don't respond to broadcast messages. The parameters for configuring the device are:

Parameter	Description	Values	Range
<b>PtS</b>	Select COM1 (TTL) protocol	p	t = Televis d = Modbus
<b>Adr</b>	Modbus protocol controller address	0	1 ... 250
<b>Pty</b>	Modbus protocol parity bit	n	<ul style="list-style-type: none"> <li>• n= NONE</li> <li>• E= EVEN</li> <li>• o= ODD</li> </ul>
<b>bAU</b>	Baudrate selection.	96	96_ 9600 192_ 19200 384_ 38400

**NOTE:** To guarantee correct operation, the controller must be switched off and switched on again after modification of parameters Pty and StP.

**IMPORTANT:** Remember to set the **2 STOP BITS**.

## 8.1.4 - PARAMETER VISIBILITY AND VALUES



### IMPORTANT:

- 1) When not indicated otherwise, the parameter is always visible and modifiable, unless customised settings have been configured via serial.
- 2) If folder visibility is modified, the new setting will apply to all parameters in the folder.





## 8.2 - MODBUS TABLES

The tables below list all information required to read, write and decode all accessible resources in the device.

There are three tables:

- The "**PARAMETERS TABLE**" contains all device configuration parameters stored in the controller's non-volatile memory, including visibility
- The "**FOLDER VISIBILITY TABLE**" indicates the visibility of the folders containing the parameters
- The "**CLIENT TABLE**" includes all I/O and alarm status resources available in the volatile memory of the instrument.

### Description of columns:

#### FOLDER

This indicates the label of the folder containing the parameter in question.

#### LABEL

This indicates the label used to display the parameters in the menu of the controller.

#### PAR. ADDRESS VALUE

The integer part represents the address of the MODBUS register containing the value of the resource to be read or written in the controller. The value after the point indicates the position of the most significant data bit inside the register; if not indicated it is taken to be zero. This information is always provided when the register contains more than one information item, and it is necessary to distinguish which bits actually represent the data (the working size of the data indicated in the column DATA SIZE is also taken into consideration).

Given that the modbus registers have the size of one WORD (16 bit), the index number after the point can vary from 0 (least significant bit -LSb-) to 15 (most significant bit -MSb-).

Examples (in binary form the least significant bit is the first on the right):

PAR. ADDRESS VALUE	DATA SIZE	Value		Content of register
8806	WORD	1350	1350	(0000010101000110)
8806	BYTE	70	1350	(00000101 <b>01000110</b> )
8806.8	BYTE	5	1350	( <b>00000101</b> 01000110)
8806.14	1 BIT	0	1350	(0 <b>00000101</b> 01000110)
8806.7	4 BIT	10	1350	(00000 <b>1010</b> 1000110)

**IMPORTANT:** when the register contains more than one piece of data, the write procedure is as follows:

- Read current value of register
- Modify bits for the resource concerned
- Write register

#### VIS PAR. ADDRESS

The same as above. In this case, the MODBUS register address contains the visibility value of the parameter.

By default all parameters have:

- Data size 2 bit
- Range 0...3
- \*\*Visibility 3
- U.M. num

#### \*\*Value Meaning

- Value 3 = parameter or folder always visible
- Value 2 = **manufacturer level**; these parameters can only be viewed by enter the manufacturer's password (see parameter UI28) (all parameters declared as always visible, parameters visible at the installer level and manufacturer's level will be visible)
- Value 1 = **installer level**; these parameters can only be viewed by enter the installer's password (see parameter UI17) (all parameters declared as always visible and parameters visible at the installer level)
- Value 0 = parameter or folder NOT visible

1. Parameters and/or folders with a level of visibility <>3 (password-protected) will be visible only if the correct password is entered (installer or manufacturer) following this procedure:
2. Parameters and/or folders with a level of visibility =3 are always visible even without a password: in this case, the following procedure is not necessary.



Examples (in binary form the least significant bit is the first on the right):

**Default visibility:**

PAR.	ADDRESS VALUE	DATA SIZE	Value	Content of register	
	49336.6	2 BIT	3	65535	------(00000000 <b>11</b> 1111111111111111)
	49337	2 BIT	3	65535	(00000000111111 <b>11</b> 1111111111)
	49337.2	2 BIT	3	65535	(000000001111 <b>11</b> 111111111111)
	49337.4	2 BIT	3	65535	(000000001 <b>11</b> 11111111111111)
	49337.6	2 BIT	3	65535	(00000000 <b>11</b> 11111111111111)

**R/W**

Indicates if resources are read/write, read-only or write-only:

- R The resource is read-only
- W The resource is write-only
- RW The resource can be both read and written to

**DESCRIPTION**

This is the description of the meaning of the **parameters** in the **LABEL** column.

**DATA SIZE**

Indicates the size of the data in bits.

- WORD = 16 bit
- Byte = 8 bit
- "n" bit = 0...15 bit based on the value of "n"

**CPL**

When the field indicates "Y", the value read by the register needs to be converted because the value represents a number with a sign. In the other cases the value is always positive or null.

To carry out conversion, proceed as follows:

- If the value in the register is between 0 and 32.767, the result is the value itself (zero and positive values)
- If the value in the register is between 32.768 and 65.535, the result is the value of the register - 65.536 (negative values)

**RANGE**

Describes the interval of values that can be assigned to the parameter. It can be correlated with other instrument parameters (indicated with the parameter label).

**UM**

Measurement unit for values converted according to the rules indicated in the CPL and EXP columns.



## 8.2.1 - PARAMETER/VISIBILITY TABLE

**N.B.:** Reading Modbus command: 04 (0x04) and Writing Modbus command: 22 (0x16)

FOLDER	LABEL	PAR. ADDRESS VALUE	PAR. ADDRESS Vis.	R/W	DESCRIPTION	DATA SIZE	CPL	RANGE	UM
	SP1	33022	43520.6	RW	Setpoint	WORD	Y	HS1...HS1	°C/°F
	SP2	33026	43521.2	RW	Thermostat 2 setpoint	WORD	Y	LS2...HS2	°C/°F
CP	rE	33016	43520	RW	Regulation mode	WORD		0...4	num
CP	rP1	33018	43520.2	RW	Regulation probe 1	WORD		0...7	num
CP	rP2	33020	43520.4	RW	Thermostat 2 regulation probe	WORD		0...7	num
CP	dF1	33024	43521	RW	Differential/proportional band	WORD	Y	-58.0...302	°C/°F
CP	dF2	33028	43521.4	RW	Thermostat 2 differential	WORD	Y	-58.0...302	°C/°F
CP	Stt	33034	43521.6	RW	Differential control mode	WORD		0/1	num
CP	HS1	33040	43522	RW	SP1 maximum value	WORD	Y	LS1...HdL	°C/°F
CP	LS1	33042	43522.2	RW	SP1 minimum value	WORD	Y	LdL...HS1	°C/°F
CP	HS2	33044	43522.4	RW	SP2 maximum value	WORD	Y	LS2...HdL	°C/°F
CP	LS2	33046	43522.6	RW	SP2 minimum value	WORD	Y	LdL...HS2	°C/°F
CP	HC1	33036	43523	RW	Thermostat 1 mode	WORD		0/1	num
CP	HC2	33038	43523.2	RW	Thermostat 2 mode	WORD		0/1	num
CP	CC	33076	43523.4	RW	Double power step control	WORD		0/1	num
CP	Cit	33056	43523.6	RW	Minimum compressor ON time	WORD		0...250	min
CP	CAt	33058	43524	RW	Maximum compressor ON time	WORD		0...250	min
CP	Ont	33068	43524.2	RW	ON time for faulty probe	WORD		0...250	min
CP	OFt	33070	43524.4	RW	OFF time for faulty probe	WORD		0...250	min
CP	dOn	33060	43524.6	RW	Switch on delay	WORD		0...250	sec
CP	dOF	33062	43525	RW	Delay after switching off	WORD		0...250	min
CP	dbi	33064	43525.2	RW	Delay between switch-ons	WORD		0...250	min
CP	OdO	33066	43525.4	RW	Output delay from power-on	WORD		0...250	min
CP	CP2	33072	43525.6	RW	Compressor 2 switch-on delay	WORD		0...250	sec
CP	CS2	33074	43526	RW	Power step 2 switch-on delay	WORD		0...250	min
CP	CFP	33234	43526.2	RW	Preventilation time	WORD		0...255	sec
CP	CFd	33236	43526.4	RW	Fan mode	WORD		0/1	num
CP	OF1	33078	43526.6	RW	Forced remote offset	WORD		-50.0...50.0	°C/°F
dEF	dP1	33080	43527	RW	Selection defrost probe 1	WORD		0...7	num
dEF	dP2	33082	43527.2	RW	Selection defrost probe 2	WORD		0...7	num
dEF	dtY	33088	43527.4	RW	Defrost mode	WORD		0...4	num
dEF	dFt	33084	43527.6	RW	Defrost activation mode with two probes	WORD		0/1/2	num
dEF	dit	33090	43528	RW	Interval between defrost cycles	WORD		0...250	hours
dEF	dt1	33096	43528.2	RW	Unit of measurement for defrost interval	WORD		0/1/2	num
dEF	dt2	33098	43528.4	RW	Unit of measure for defrost duration	WORD		0/1/2	num
dEF	dCt	33086	43528.6	RW	Defrost interval count mode	WORD		0...5	num
dEF	dOH	33100	43529	RW	Defrost interval count mode	WORD		0...250	min
dEF	dE1	33092	43529.2	RW	Evaporator 1 defrost time-out	WORD		1...250	min
dEF	dE2	33094	43529.4	RW	Evaporator 2 defrost time-out	WORD		1...250	min
dEF	dS1	33104	43529.6	RW	Probe 1 end of defrost temperature	WORD	Y	-58.0...302	°C/°F
dEF	dS2	33106	43530	RW	Probe 2 end of defrost temperature	WORD	Y	-58.0...302	°C/°F
dEF	dSS	33102	43530.2	RW	Start defrost temperature threshold	WORD	Y	-58.0...302	°C/°F
dEF	dPO	33108	43530.4	RW	Request defrost activation from power on	WORD		0/1	num
dEF	tcd	33110	43530.6	RW	Min. compressor ON or OFF time before defrost	WORD	Y	-60...60	min
dEF	ndE	33112	43531	RW	Minimum defrost time (for hot gas only)	WORD		0...250	min
dEF	PdC	33114	43531.2	RW	Hot gas extraction time at defrost end	WORD		0...250	min
dEF	tPd	33118	43531.4	RW	Pump down time before defrost startup	WORD		0...255	min
dEF	dPH	32996	43531.6	RW	Start time for periodical defrost	WORD		0...24	hours
dEF	dPn	32998	43532	RW	Start time minutes for periodical defrost	WORD		0...59	min
dEF	dPd	33000	43532.2	RW	Periodical defrost interval duration	WORD		1...7	Day
dEF	Fd1	32894	43532.4	RW	Weekend/public holiday 1	WORD		0...7	num
dEF	Fd2	32896	43532.6	RW	Weekend/public holiday 2	WORD		0...7	num
dEF	Edt	32898	43533	RW	Customized duration and temperature for each event	WORD		0/1	num



FOLDER	LABEL	PAR. ADDRESS VALUE	PAR. ADDRESS Vis.	R/W	DESCRIPTION	DATA SIZE	CPL	RANGE	UM
dEF	d1H	32900	43533.2	RW	Start time weekday defrost 1	WORD		0...24	hours
dEF	d1n	32902	43533.4	RW	Start time minutes weekday defrost 1	WORD		0...59	min
dEF	d1t	32904	43533.6	RW	Weekday defrost 1 duration	WORD		0...250	min
dEF	d1S	32906	43534	RW	End of weekday defrost 1 temperature	WORD	Y	-58.0...302	°C/°F
dEF	d2H	32908	43534.2	RW	Start time weekday defrost 2	WORD		d1H...24	hours
dEF	d2n	32910	43534.4	RW	Start time minutes weekday defrost 2	WORD		0...59	min
dEF	d2t	32912	43534.6	RW	Weekday defrost 2 duration	WORD		0...250	min
dEF	d2S	32914	43535	RW	End of weekday defrost 2 temperature	WORD	Y	-58.0...302	°C/°F
dEF	d3H	32916	43535.2	RW	Start time weekday defrost 3	WORD		d2H...24	hours
dEF	d3n	32918	43535.4	RW	Start time minutes weekday defrost 3	WORD		0...59	min
dEF	d3t	32920	43535.6	RW	Weekday defrost 3 duration	WORD		0...250	min
dEF	d3S	32922	43536	RW	End of weekday defrost 3 temperature	WORD	Y	-58.0...302	°C/°F
dEF	d4H	32924	43536.2	RW	Start time weekday defrost 4	WORD		d3H...24	hours
dEF	d4n	32926	43536.4	RW	Start time minutes weekday defrost 4	WORD		0...59	min
dEF	d4t	32928	43536.6	RW	Weekday defrost 4 duration	WORD		0...250	min
dEF	d4S	32930	43537	RW	End of weekday defrost 4 temperature	WORD	Y	-58.0...302	°C/°F
dEF	d5H	32932	43537.2	RW	Start time weekday defrost 5	WORD		d4H...24	hours
dEF	d5n	32934	43537.4	RW	Start time minutes weekday defrost 5	WORD		0...59	min
dEF	d5t	32936	43537.6	RW	Weekday defrost 5 duration	WORD		0...250	min
dEF	d5S	32938	43538	RW	End of weekday defrost 5 temperature	WORD	Y	-58.0...302	°C/°F
dEF	d6H	32940	43538.2	RW	Start time weekday defrost 6	WORD		d5H...24	hours
dEF	d6n	32942	43538.4	RW	Start time minutes weekday defrost 6	WORD		0...59	min
dEF	d6t	32944	43538.6	RW	Weekday defrost 6 duration	WORD		0...250	min
dEF	d6S	32946	43539	RW	End of weekday defrost 6 temperature	WORD	Y	-58.0...302	°C/°F
dEF	F1H	32948	43539.2	RW	Start time weekend/public holiday defrost 1	WORD		0...24	hours
dEF	F1n	32950	43539.4	RW	Weekend/public holiday defrost 1 start time minutes	WORD		0...59	min
dEF	F1t	32952	43539.6	RW	Weekend/public holiday defrost 1 duration	WORD		0...250	min
dEF	F1S	32954	43540	RW	End of weekend/public holiday defrost 1 temperature	WORD	Y	-58.0...302	°C/°F
dEF	F2H	32956	43540.2	RW	Start time weekend/public holiday defrost 2	WORD		F1H...24	hours
dEF	F2n	32958	43540.4	RW	Weekend/public holiday defrost 2 start time minutes	WORD		0...59	min
dEF	F2t	32960	43540.6	RW	Weekend/public holiday defrost 2 duration	WORD		0...250	min
dEF	F2S	32962	43541	RW	End of weekend/public holiday defrost 1 temperature	WORD	Y	-58.0...302	°C/°F
dEF	F3H	32964	43541.2	RW	Start time weekend/public holiday defrost 3	WORD		F2H...24	hours
dEF	F3n	32966	43541.4	RW	Weekend/public holiday defrost 3 start time minutes	WORD		0...59	min
dEF	F3t	32968	43541.6	RW	Weekend/public holiday defrost 3 duration	WORD		0...250	min
dEF	F3S	32970	43542	RW	End of weekend/public holiday defrost 1 temperature	WORD	Y	-58.0...302	°C/°F
dEF	F4H	32972	43542.2	RW	Start time weekend/public holiday defrost 4	WORD		F3H...24	hours
dEF	F4n	32974	43542.4	RW	Weekend/public holiday defrost 4 start time minutes	WORD		0...59	min
dEF	F4t	32976	43542.6	RW	Weekend/public holiday defrost 4 duration	WORD		0...250	min
dEF	F4S	32978	43543	RW	End of weekend/public holiday defrost 1 temperature	WORD	Y	-58.0...302	°C/°F
dEF	F5H	32980	43543.2	RW	Start time weekend/public holiday defrost 5	WORD		F4H...24	hours
dEF	F5n	32982	43543.4	RW	Weekend/public holiday defrost 5 start time minutes	WORD		0...59	min
dEF	F5t	32984	43543.6	RW	Weekend/public holiday defrost 5 duration	WORD		0...250	min
dEF	F5S	32986	43544	RW	End of weekend/public holiday defrost 1 temperature	WORD	Y	-58.0...302	°C/°F
dEF	F6H	32988	43544.2	RW	Start time weekend/public holiday defrost 6	WORD		F5H...24	hours
dEF	F6n	32990	43544.4	RW	Weekend/public holiday defrost 6 start time minutes	WORD		0...59	min
dEF	F6t	32992	43544.6	RW	Weekend/public holiday defrost 6 duration	WORD		0...250	min
dEF	F6S	32994	43545	RW	End of weekend/public holiday defrost 6 temperature	WORD	Y	-58.0...302	°C/°F
FAn	FP1	33120	43545.2	RW	Evaporator fan probe in normal mode	WORD		0...7	num
FAn	FP2	33122	43545.4	RW	Evaporator fan probe during defrost stage	WORD		0...7	num
FAn	FPt	33124	43545.6	RW	FSt parameter mode	WORD		0/1	num
FAn	FSt	33126	43546	RW	Block fan temperature	WORD	Y	-58.0...302	°C/°F
FAn	FAd	33128	43546.2	RW	Fan differential	WORD		0.1...25.0	°C/°F
FAn	Fdt	33130	43546.4	RW	Fan activation delay after compressor start	WORD		0...250	min
FAn	dt	33140	43546.6	RW	Dripping time	WORD		0...250	min
FAn	dFd	33136	43547	RW	Evaporator fan mode during defrost	WORD		0/1	num



FOLDER	LABEL	PAR. ADDRESS VALUE	PAR. ADDRESS Vis.	R/W	DESCRIPTION	DATA SIZE	CPL	RANGE	UM
FAn	FCO	33134	43547.2	RW	Evaporator fan mode	WORD		0...4	num
FAn	FdC	33132	43547.6	RW	Fan switch off delay after compressor stop	WORD		0...250	min
FAn	FOn	33142	43548	RW	Fan ON time in Duty Cycle	WORD		0...250	min
FAn	FOF	33144	43548.2	RW	Fan OFF time in Duty Cycle	WORD		0...250	min
FAn	Fnn	33146	43548.4	RW	Duty cycle on time during night mode	WORD		0...250	min
FAn	FnF	33148	43548.6	RW	Duty cycle off time during night mode	WORD		0...250	min
AL	rA1	33176	43549	RW	Temperature alarm probe 1 selection	WORD		0...6	num
AL	rA2	33178	43549.2	RW	Temperature alarm probe 2 selection	WORD		0...6	num
AL	Att	33180	43549.4	RW	Parameter HAL and LAL mode	WORD		0/1	num
AL	AFd	33182	43549.6	RW	Alarm setpoint differential	WORD		0.1...25.0	°C/°F
AL	HA1	33184	43550	RW	Probe 1 maximum alarm	WORD	Y	LA1...302	°C/°F
AL	LA1	33186	43550.2	RW	Probe 1 minimum alarm	WORD	Y	-58.0...HA1	°C/°F
AL	HA2	33188	43550.4	RW	Probe 2 maximum alarm	WORD	Y	LA2...302	°C/°F
AL	LA2	33190	43550.6	RW	Probe 2 minimum alarm	WORD	Y	-58.0...HA2	°C/°F
AL	PAO	33192	43551	RW	Exclude alarm at switch on	WORD		0...10	hours
AL	dAO	33196	43551.2	RW	Exclude alarm after defrost	WORD		0...250	min
AL	OAO	33194	43551.4	RW	Alarm signal delay after closing door	WORD		0...10	hours
AL	tdO	33284	43551.6	RW	Open door disabling time	WORD		0...250	min
AL	tA1	33198	43552	RW	LA1 and HA1 alarm signal delay	WORD		0...250	min
AL	tA2	33200	43552.2	RW	LA2 and HA2 alarm signal delay	WORD		0...250	min
AL	dAt	33116	43552.4	RW	Enable alarm at end of defrost	WORD		0/1	num
AL	EAL	33204	43552.6	RW	External alarm switches off utilities	WORD		0/1/2	num
AL	tP	33286	43553	RW	Enable alarm overriding from any key	WORD		0/1	min
AL	Art	33174	43553.2	RW	Alarm activation period supervisor link	WORD		0...250	min*10
Lit	dSd	33168	43553.4	RW	Enable light relay from door switch	WORD		0/1	num
Lit	dLt	33170	43553.6	RW	Delay disabling light relay	WORD		0...250	min
Lit	OFL	33172	43554	RW	Light key always disables light relay	WORD		0/1	num
Lit	dOd	33202	43554.2	RW	Door switch turns off utilities	WORD		0...3	num
Lit	dOA	33206	43554.4	RW	Action forced by digital input	WORD		0...5	num
Lit	PEA	33208	43554.6	RW	DI selected to block/release resources	WORD		0...3	num
Lit	dCO	33210	43555	RW	Delay to activate/switch off compressor evap. fan	WORD		0...250	min
Lit	dFO	33212	43555.2	RW	Delay to activate/switch off evap. fan	WORD		0...250	min
Lit	ASb	33264	43555.4	RW	Key/AUX input/Light active when OFF	WORD		0/1	num
Lin	L00	32768	43555.6	RW	Shared probe	WORD		0...6	num
Lin	L01	32770	43556	RW	Display value shared	WORD		0/1/2	num
Lin	L02	32772	43556.2	RW	Send setpoint value when modified	WORD		0/1	num
Lin	L03	32774	43556.4	RW	Send defrost request	WORD		0/1	num
Lin	L04	32776	43556.6	RW	End defrost mode	WORD		0/1	num
Lin	L05	32778	43557	RW	Synchronization of Stand-By command	WORD		0/1	num
Lin	L06	32780	43557.2	RW	Synchronization of light command	WORD		0/1	num
Lin	L07	32782	43557.4	RW	Synchronization of reduced setpoint command	WORD		0/1	num
Lin	L08	32784	43557.6	RW	Synchronization of AUX command	WORD		0/1	num
Lin	L10	33288	43558.2	RW	Wait for end of dependent defrost timeout	WORD		0...250	min
PrE	PEn	33164	43558.4	RW	Number of errors allowed	WORD		0...15	num
PrE	PEi	33166	43558.6	RW	Error count interval	WORD		1...250	min
dEC	dCS	33156	43559	RW	Deep Cooling Setpoint	WORD	Y	-58.0...302	°C/°F
dEC	tdc	33158	43559.2	RW	Deep Cooling duration	WORD		0...250	min
dEC	dcc	33160	43559.4	RW	Waiting time to start defrost cycle	WORD		0...250	min
EnS	ESt	33014	43559.6	RW	Type of Energy Saving	WORD		0...4	num
EnS	ESF	33150	43560	RW	Night mode enabled	WORD		0/1	num
EnS	Cdt	33152	43560.2	RW	Min. door closed time to activate reduced setpoint	WORD		0...255	min*10
EnS	ESo	33154	43560.4	RW	Cumulative door open time	WORD		0...10	num
EnS	OS1	33048	43560.6	RW	Offset SP1	WORD	Y	-50.0...50.0	°C/°F
EnS	OS2	33050	43561	RW	Offset SP2	WORD	Y	-50.0...50.0	°C/°F
EnS	Od1	33052	43561.2	RW	Door energy saving offset 1	WORD	Y	-50.0...50.0	°C/°F
EnS	Od2	33054	43561.4	RW	Door energy saving offset 2	WORD	Y	-50.0...50.0	°C/°F



FOLDER	LABEL	PAR. ADDRESS VALUE	PAR. ADDRESS Vis.	R/W	DESCRIPTION	DATA SIZE	CPL	RANGE	UM
EnS	dn1	33030	43561.6	RW	dn1 Differential in energy saving mode 1	WORD	Y	-58.0...302	°C/°F
EnS	dn2	33032	43562	RW	dn2 Differential in energy saving mode 2	WORD	Y	-58.0...302	°C/°F
EnS	EdH	33002	43562.2	RW	Start time weekday Energy Saving	WORD		0...24	hours
EnS	Edn	33004	43562.4	RW	Weekday Energy Saving start time minutes	WORD		0...59	min
EnS	Edd	33006	43562.6	RW	Weekday Energy Saving event duration	WORD		1...72	hours
EnS	EFH	33008	43563	RW	Weekend/public holiday Energy Saving start time	WORD		0...24	hours
EnS	EFn	33010	43563.2	RW	Weekend/public holiday Energy Saving start time minutes	WORD		0...59	min
EnS	EFd	33012	43563.4	RW	Weekend/public holiday Energy Saving event duration	WORD		1...72	hours
FrH	FH	33214	43563.6	RW	Regulation mode	WORD		0...7	num
FrH	FHt	33218	43564	RW	Frame heater period	WORD		1...250	sec*10
FrH	FHO	33220	43564.2	RW	Frame heater setpoint	WORD	Y	-58.0...302	°C/°F
FrH	FH1	33222	43564.4	RW	Frame heater offset	WORD		0.0...25.0	°C/°F
FrH	FH2	33224	43564.6	RW	Frame heater band	WORD		0.0...25.0	°C/°F
FrH	FH3	33226	43565	RW	Min. percentage	WORD		0...100	%
FrH	FH4	33228	43565.2	RW	Maximum percentage/Duty Cycle Day	WORD		0...100	%
FrH	FH5	33230	43565.4	RW	Maximum percentage/Duty Cycle Night (ES)	WORD		0...100	%
FrH	FH6	33232	43565.6	RW	Percentage during defrost	WORD		0...100	%
Add	PtS	33538	43601.6	RW	Protocol selection (0: Micronet; 1: modbus)	WORD		0/1	num
Add	dEA	33542	43602	RW	Device address, Micronet	WORD		0...14	num
Add	FAA	33544	43602.2	RW	Device family, Micronet	WORD		0...14	num
Add	Adr	33546	43602.4	RW	Modbus address	WORD		1...250	num
Add	bAU	33536	43602.6	RW	BaudRate	WORD		0/1/2	num
Add	Pty	33540	43603	RW	Parity (Modbus protocol)	WORD		0/1/2	num
diS	LOC	33238	43566	RW	Keypad lock	WORD		0/1	num
diS	PS1	33240	43566.2	RW	Password 1	WORD		0...250	num
diS	PS2	33242	43566.4	RW	Password 2	WORD		0...250	num
diS	ndt	33244	43566.6	RW	Display with decimal point	WORD		0/1	num
diS	CA1	32856	43567	RW	Calibration Pb1	WORD	Y	-30.0...30.0	°C/°F
diS	CA2	32858	43567.2	RW	Calibration Pb2	WORD	Y	-30.0...30.0	°C/°F
diS	CA3	32860	43567.4	RW	Calibration Pb3	WORD	Y	-30.0...30.0	°C/°F
diS	CA4	32862	43567.6	RW	Calibration Pb4	WORD	Y	-30.0...30.0	°C/°F
diS	CA5	32864	43568	RW	Calibration Pb5	WORD	Y	-30.0...30.0	°C/°F
diS	LdL	33246	43568.6	RW	Minimum value displayable	WORD	Y	-58.0...HdL	°C/°F
diS	HdL	33248	43569	RW	Maximum value displayable	WORD	Y	LdL...302	°C/°F
diS	ddL	33250	43569.2	RW	Block display during defrost	WORD		0/1/2	num
diS	Ldd	33252	43569.4	RW	"ddL" Release Time-Out	WORD		0...250	minutes
diS	dro	33254	43569.6	RW	°C/°F selection (0=°C, 1=°F)	WORD		0/1	num
diS	ddd	33258	43570.2	RW	Main Display	WORD		0...7	num
diS	ddE	33260	43570.4	RW	Main display on ECHO	WORD		0...7	num
HCP	rPH	33162	43570.6	RW	Select HACCP alarm probe	WORD		0...5	num
CnF	H00	32788	43571	RW	Type of probe Pb1-Pb2-Pb3-Pb4-Pb5 (0=NTC, 1=PTC, 2=PT1000)	WORD		0/1/2	num
CnF	H02	33262	43571.2	RW	Key activation time	WORD		0...250	sec
CnF	H03	33560	43603.4	RW	4-20mA probe lower limit	WORD	Y	-1.0...H04	bar/Psi
CnF	H04	33562	43603.6	RW	4-20mA probe upper limit	WORD	Y	H03...150.0	bar/Psi
CnF	H05	33564	43604	RW	Ratiometric probe lower limit	WORD	Y	-1.0...H06	bar/Psi
CnF	H06	33566	43604.2	RW	Ratiometric probe upper limit	WORD	Y	H05...150.0	bar/Psi
CnF	H08	33266	43571.4	RW	Stand-By mode	WORD		0/1/2	num
CnF	H11	32798	43571.6	RW	Configuration input DI1	WORD	Y	-17...17	num
CnF	H12	32800	43572	RW	Configuration input DI2	WORD	Y	-17...17	num
CnF	H13	32802	43572.2	RW	Configuration input DI3	WORD	Y	-17...17	num
CnF	H14	32804	43572.4	RW	Configuration input DI4	WORD	Y	-17...17	num
CnF	H15	32806	43572.6	RW	Configuration input DI5	WORD	Y	-17...17	num
CnF	H16	32808	43573	RW	Configuration input DI6	WORD	Y	-17...17	num
CnF	H17	32810	43573.2	RW	Configuration input DI7	WORD	Y	-17...17	num
CnF	H18	32812	43573.4	RW	Configuration input DI8	WORD	Y	-17...17	num
CnF	dti	32830	43573.6	RW	Unit of measure for digital inputs 1 and 2	WORD		0/1	num



FOLDER	LABEL	PAR. ADDRESS VALUE	PAR. ADDRESS Vis.	R/W	DESCRIPTION	DATA SIZE	CPL	RANGE	UM
CnF	d11	32814	43574	RW	Activation delay for digital input 1	WORD		0...255	min/sec
CnF	d12	32816	43574.2	RW	Activation delay for digital input 2	WORD		0...255	min/sec
CnF	d13	32818	43574.4	RW	Activation delay for digital input 3	WORD		0...255	min
CnF	d14	32820	43574.6	RW	Activation delay for digital input 4	WORD		0...255	min
CnF	d15	32822	43575	RW	Activation delay for digital input 5	WORD		0...255	min
CnF	d16	32824	43575.2	RW	Activation delay for digital input 6	WORD		0...255	min
CnF	d17	32826	43575.4	RW	Activation delay for digital input 7	WORD		0...255	min
CnF	d18	32828	43575.6	RW	Activation delay for digital input 8	WORD		0...255	min
CnF	H21	32872	43576	RW	Configuration Relay 1	WORD		0...13	num
CnF	H22	32874	43576.2	RW	Configuration Relay 2	WORD		0...13	num
CnF	H23	32876	43576.4	RW	Configuration Relay 3	WORD		0...13	num
CnF	H24	32878	43576.6	RW	Configuration Relay 4	WORD		0...13	num
CnF	H25	32880	43577	RW	Configuration Relay 5	WORD		0...13	num
CnF	H26	32882	43577.2	RW	Configuration Relay 6	WORD		0...13	num
CnF	H27	32884	43577.4	RW	Configuration Relay 7	WORD		0...13	num
CnF	H29	32886	43577.6	RW	Enable buzzer	WORD		0/1	num
CnF	H31	33268	43578	RW	Configuration of UP key	WORD		0...8	num
CnF	H32	33270	43578.2	RW	Configuration of DOWN key	WORD		0...8	num
CnF	H33	33272	43578.4	RW	ESC key configuration	WORD		0...8	num
CnF	H41	32832	43579.6	RW	Configuration input Pb1 (0=Disable, 1=DI, 2=H00)	WORD		0/1/2	num
CnF	H42	32834	43580	RW	Configuration input Pb2 (0=Disable, 1=DI, 2=H00)	WORD		0/1/2	num
CnF	H43	32836	43580.2	RW	Configuration input Pb3 (0=Disable, 1=DI, 2=H00)	WORD		0/1/2	num
CnF	H44	32838	43580.4	RW	Configuration input Pb4 (0=Disable, 1=DI, 2=H00)	WORD		0/1/2	num
CnF	H45	32840	43580.6	RW	Configuration input Pb5 (0=Disable, 1=DI, 2=H00)	WORD		0/1/2	num
CnF	H50	32888	43581.4	RW	Configuration Type of Analogue Output	WORD		0/1	num
CnF	H51	32890	43581.6	RW	Regulator associated to analogue output	WORD		0/1	num
CnF	H60	33548	43604.4	RW	Select Preset	WORD		0...8	num
CnF	H68	32892	43582	RW	Clock Present	WORD		0/1	num
CnF	rEL	---	43600.2	RW	Device version	2 BIT		0...3	num
CnF	tAb	---	43600.4	RW	Map code	2 BIT		0...3	num
CnF	H70	32848	43582.2	RW	Select probe 1 for virtual probe	WORD		0...5	num
CnF	H71	32850	43582.4	RW	Select probe 2 for virtual probe	WORD		0...5	num
CnF	H72	32852	43582.6	RW	% calculation virtual probe day	WORD		0...100	%
CnF	H73	32854	43583	RW	% calculation virtual probe night	WORD		0...100	%
FPr	UL	---	43588	RW	Parameter transfer function visibility (Device -> Copy Card)	2 BIT		0...3	num
FPr	dL	---	43588.2	RW	Parameter transfer function visibility (Copy Card -> Device)	2 BIT		0...3	num
FPr	Fr	---	43588.4	RW	Format Copy Card function visibility	2 BIT		0...3	num

#### APPLICATION 1 PARAMETERS

	V1-SP1	36094	43776.6	RW	Setpoint	WORD		V1-LS1...V1-HS1	°C/°F
	V1-SP2	36098	43777.2	RW	Thermostat 2 setpoint	WORD		V1-LS2...V1-HS2	°C/°F
V1	V1-rE	36088	43776	RW	Regulation mode	WORD		0...4	num
V1	V1-rP1	36090	43776.2	RW	Regulation probe 1	WORD		0...7	num
V1	V1-rP2	36092	43776.4	RW	Thermostat 2 regulation probe	WORD		0...7	num
V1	V1-dF1	36096	43777	RW	Differential/proportional band	WORD		-58.0...302	°C/°F
V1	V1-dF2	36100	43777.4	RW	Thermostat 2 differential	WORD		-58.0...302	°C/°F
V1	V1-Stt	36106	43777.6	RW	Differential control mode	WORD		0/1	num
V1	V1-HS1	36112	43778	RW	SP1 maximum value	WORD		V1-LS1...V1-HdL	°C/°F
V1	V1-LS1	36114	43778.2	RW	SP1 minimum value	WORD		V1-LdL...V1-HS1	°C/°F
V1	V1-HS2	36116	43778.4	RW	SP2 maximum value	WORD		V1-LS2...V1-HdL	°C/°F
V1	V1-LS2	36118	43778.6	RW	SP2 minimum value	WORD		V1-LdL...V1-HS2	°C/°F
V1	V1-HC1	36108	43779	RW	Thermostat 1 mode	WORD		0/1	num
V1	V1-HC2	36110	43779.2	RW	Thermostat 2 mode	WORD		0/1	num
V1	V1-CC	36148	43779.4	RW	Double power step control	WORD		0/1	num
V1	V1-Cit	36128	43779.6	RW	Minimum compressor ON time	WORD		0...250	min
V1	V1-CAt	36130	43780	RW	Maximum compressor ON time	WORD		0...250	min
V1	V1-Ont	36140	43780.2	RW	ON time for faulty probe	WORD		0...250	min



FOLDER	LABEL	PAR. ADDRESS VALUE	PAR. ADDRESS Vis.	R/W	DESCRIPTION	DATA SIZE	CPL	RANGE	UM
V1	V1-OfT	36142	43780.4	RW	OFF time for faulty probe	WORD		0...250	min
V1	V1-dOn	36132	43780.6	RW	Switch on delay	WORD		0...250	sec
V1	V1-dOF	36134	43781	RW	Delay after switching off	WORD		0...250	min
V1	V1-dbi	36136	43781.2	RW	Delay between switch-ons	WORD		0...250	min
V1	V1-OdO	36138	43781.4	RW	Output delay from power-on	WORD		0...250	min
V1	V1-CP2	36144	43781.6	RW	Compressor 2 switch-on delay	WORD		0...250	sec
V1	V1-CS2	36146	43782	RW	Power step 2 switch-on delay	WORD		0...250	min
V1	V1-CFP	36306	43782.2	RW	Preventilation time	WORD		0...255	sec
V1	V1-CFd	36308	43782.4	RW	Fan mode	WORD		0/1	num
V1	V1-OF1	36150	43782.6	RW	Forced remote offset	WORD		-50.0...50.0	°C/°F
V1	V1-dP1	36152	43783	RW	Selection defrost probe 1	WORD		0...7	num
V1	V1-dP2	36154	43783.2	RW	Selection defrost probe 2	WORD		0...7	num
V1	V1-dtY	36160	43783.4	RW	Defrost mode	WORD		0...4	num
V1	V1-dFt	36156	43783.6	RW	Defrost activation mode with two probes	WORD		0/1/2	num
V1	V1-dit	36162	43784	RW	Interval between defrost cycles	WORD		0...250	hours
V1	V1-dt1	36168	43784.2	RW	Unit of measurement for defrost interval	WORD		0/1/2	num
V1	V1-dt2	36170	43784.4	RW	Unit of measure for defrost duration	WORD		0/1/2	num
V1	V1-dCt	36158	43784.6	RW	Defrost interval count mode	WORD		0...5	num
V1	V1-dOH	36172	43785	RW	Defrost interval count mode	WORD		0...250	min
V1	V1-dE1	36164	43785.2	RW	Evaporator 1 defrost time-out	WORD		1...250	min
V1	V1-dE2	36166	43785.4	RW	Evaporator 2 defrost time-out	WORD		1...250	min
V1	V1-dS1	36176	43785.6	RW	Probe 1 end of defrost temperature	WORD		-58.0...302	°C/°F
V1	V1-dS2	36178	43786	RW	Probe 2 end of defrost temperature	WORD		-58.0...302	°C/°F
V1	V1-dSS	36174	43786.2	RW	Start defrost temperature threshold	WORD		-58.0...302	°C/°F
V1	V1-dPO	36180	43786.4	RW	Request defrost activation from power on	WORD		0/1	num
V1	V1-tcd	36182	43786.6	RW	Min. compressor ON or OFF time before defrost	WORD		-60...60	min
V1	V1-ndE	36184	43787	RW	Minimum defrost time (for hot gas only)	WORD		0...250	min
V1	V1-PdC	36186	43787.2	RW	Hot gas extraction time at defrost end	WORD		0...250	min
V1	V1-tPd	36190	43787.4	RW	Pump down time before defrost startup	WORD		0...255	min
V1	V1-dPH	36068	43787.6	RW	Start time for periodical defrost	WORD		0...24	hours
V1	V1-dPn	36070	43788	RW	Start time minutes for periodical defrost	WORD		0...59	min
V1	V1-dPd	36072	43788.2	RW	Periodical defrost interval duration	WORD		1...7	Day
V1	V1-Fd1	35966	43788.4	RW	Weekend/public holiday 1	WORD		0...7	num
V1	V1-Fd2	35968	43788.6	RW	Weekend/public holiday 2	WORD		0...7	num
V1	V1-Edt	35970	43789	RW	Customized duration and temperature for each event	WORD		0/1	num
V1	V1-d1H	35972	43789.2	RW	Start time weekday defrost 1	WORD		0...24	hours
V1	V1-d1n	35974	43789.4	RW	Start time minutes weekday defrost 1	WORD		0...59	min
V1	V1-d1t	35976	43789.6	RW	Weekday defrost 1 duration	WORD		0...250	min
V1	V1-d1S	35978	43790	RW	End of weekday defrost 1 temperature	WORD		-58.0...302	°C/°F
V1	V1-d2H	35980	43790.2	RW	Start time weekday defrost 2	WORD		V1-d1H...24	hours
V1	V1-d2n	35982	43790.4	RW	Start time minutes weekday defrost 2	WORD		0...59	min
V1	V1-d2t	35984	43790.6	RW	Weekday defrost 2 duration	WORD		0...250	min
V1	V1-d2S	35986	43791	RW	End of weekday defrost 2 temperature	WORD		-58.0...302	°C/°F
V1	V1-d3H	35988	43791.2	RW	Start time weekday defrost 3	WORD		V1-d2H...24	hours
V1	V1-d3n	35990	43791.4	RW	Start time minutes weekday defrost 3	WORD		0...59	min
V1	V1-d3t	35992	43791.6	RW	Weekday defrost 3 duration	WORD		0...250	min
V1	V1-d3S	35994	43792	RW	End of weekday defrost 3 temperature	WORD		-58.0...302	°C/°F
V1	V1-d4H	35996	43792.2	RW	Start time weekday defrost 4	WORD		V1-d3H...24	hours
V1	V1-d4n	35998	43792.4	RW	Start time minutes weekday defrost 4	WORD		0...59	min
V1	V1-d4t	36000	43792.6	RW	Weekday defrost 4 duration	WORD		0...250	min
V1	V1-d4S	36002	43793	RW	End of weekday defrost 4 temperature	WORD		-58.0...302	°C/°F
V1	V1-d5H	36004	43793.2	RW	Start time weekday defrost 5	WORD		V1-d4H...24	hours
V1	V1-d5n	36006	43793.4	RW	Start time minutes weekday defrost 5	WORD		0...59	min
V1	V1-d5t	36008	43793.6	RW	Weekday defrost 5 duration	WORD		0...250	min
V1	V1-d5S	36010	43794	RW	End of weekday defrost 5 temperature	WORD		-58.0...302	°C/°F
V1	V1-d6H	36012	43794.2	RW	Start time weekday defrost 6	WORD		V1-d5H...24	hours





FOLDER	LABEL	PAR. ADDRESS VALUE	PAR. ADDRESS Vis.	R/W	DESCRIPTION	DATA SIZE	CPL	RANGE	UM
V1	V1-d6n	36014	43794.4	RW	Start time minutes weekday defrost 6	WORD		0...59	min
V1	V1-d6t	36016	43794.6	RW	Weekday defrost 6 duration	WORD		0...250	min
V1	V1-d6S	36018	43795	RW	End of weekday defrost 6 temperature	WORD		-58.0...302	°C/°F
V1	V1-F1H	36020	43795.2	RW	Start time weekend/public holiday defrost 1	WORD		0...24	hours
V1	V1-F1n	36022	43795.4	RW	Weekend/public holiday defrost 1 start time minutes	WORD		0...59	min
V1	V1-F1t	36024	43795.6	RW	Weekend/public holiday defrost 1 duration	WORD		0...250	min
V1	V1-F1S	36026	43796	RW	End of weekend/public holiday defrost 1 temperature	WORD		-58.0...302	°C/°F
V1	V1-F2H	36028	43796.2	RW	Start time weekend/public holiday defrost 2	WORD		V1-F1H...24	hours
V1	V1-F2n	36030	43796.4	RW	Weekend/public holiday defrost 2 start time minutes	WORD		0...59	min
V1	V1-F2t	36032	43796.6	RW	Weekend/public holiday defrost 2 duration	WORD		0...250	min
V1	V1-F2S	36034	43797	RW	End of weekend/public holiday defrost 1 temperature	WORD		-58.0...302	°C/°F
V1	V1-F3H	36036	43797.2	RW	Start time weekend/public holiday defrost 3	WORD		V1-F2H...24	hours
V1	V1-F3n	36038	43797.4	RW	Weekend/public holiday defrost 3 start time minutes	WORD		0...59	min
V1	V1-F3t	36040	43797.6	RW	Weekend/public holiday defrost 3 duration	WORD		0...250	min
V1	V1-F3S	36042	43798	RW	End of weekend/public holiday defrost 1 temperature	WORD		-58.0...302	°C/°F
V1	V1-F4H	36044	43798.2	RW	Start time weekend/public holiday defrost 4	WORD		V1-F3H...24	hours
V1	V1-F4n	36046	43798.4	RW	Weekend/public holiday defrost 4 start time minutes	WORD		0...59	min
V1	V1-F4t	36048	43798.6	RW	Weekend/public holiday defrost 4 duration	WORD		0...250	min
V1	V1-F4S	36050	43799	RW	End of weekend/public holiday defrost 1 temperature	WORD		-58.0...302	°C/°F
V1	V1-F5H	36052	43799.2	RW	Start time weekend/public holiday defrost 5	WORD		V1-F4H...24	hours
V1	V1-F5n	36054	43799.4	RW	Weekend/public holiday defrost 5 start time minutes	WORD		0...59	min
V1	V1-F5t	36056	43799.6	RW	Weekend/public holiday defrost 5 duration	WORD		0...250	min
V1	V1-F5S	36058	43800	RW	End of weekend/public holiday defrost 1 temperature	WORD		-58.0...302	°C/°F
V1	V1-F6H	36060	43800.2	RW	Start time weekend/public holiday defrost 6	WORD		V1-F5H...24	hours
V1	V1-F6n	36062	43800.4	RW	Weekend/public holiday defrost 6 start time minutes	WORD		0...59	min
V1	V1-F6t	36064	43800.6	RW	Weekend/public holiday defrost 6 duration	WORD		0...250	min
V1	V1-F6S	36066	43801	RW	End of weekend/public holiday defrost 6 temperature	WORD		-58.0...302	°C/°F
V1	V1-FP1	36192	43801.2	RW	Evaporator fan probe in normal mode	WORD		0...7	num
V1	V1-FP2	36194	43801.4	RW	Evaporator fan probe during defrost stage	WORD		0...7	num
V1	V1-FPt	36196	43801.6	RW	FSt parameter mode	WORD		0/1	num
V1	V1-FSt	36198	43802	RW	Block fan temperature	WORD		-58.0...302	°C/°F
V1	V1-FAd	36200	43802.2	RW	Fan differential	WORD		0.1...25.0	°C/°F
V1	V1-Fdt	36202	43802.4	RW	Fan activation delay after compressor start	WORD		0...250	min
V1	V1-dt	36212	43802.6	RW	Dripping time	WORD		0...250	min
V1	V1-dFd	36208	43803	RW	Evaporator fan mode during defrost	WORD		0/1	num
V1	V1-FCO	36206	43803.2	RW	Evaporator fan mode	WORD		0...3	num
V1	V1-FdC	36204	43803.6	RW	Fan switch off delay after compressor stop	WORD		0...250	min
V1	V1-FOn	36214	43804	RW	Fan ON time in Duty Cycle	WORD		0...250	min
V1	V1-FOF	36216	43804.2	RW	Fan OFF time in Duty Cycle	WORD		0...250	min
V1	V1-Fnn	36218	43804.4	RW	Duty cycle on time during night mode	WORD		0...250	min
V1	V1-FnF	36220	43804.6	RW	Duty cycle off time during night mode	WORD		0...250	min
V1	V1-rA1	36248	43805	RW	Temperature alarm probe 1 selection	WORD		0...6	num
V1	V1-rA2	36250	43805.2	RW	Temperature alarm probe 2 selection	WORD		0...6	num
V1	V1-Att	36252	43805.4	RW	Parameter HAL and LAL mode	WORD		0/1	num
V1	V1-AFd	36254	43805.6	RW	Alarm setpoint differential	WORD		0.1...25.0	°C/°F
V1	V1-HA1	36256	43806	RW	Probe 1 maximum alarm	WORD		V1-LA1...302	°C/°F
V1	V1-LA1	36258	43806.2	RW	Probe 1 minimum alarm	WORD		-58.0...V1-HA1	°C/°F
V1	V1-HA2	36260	43806.4	RW	Probe 2 maximum alarm	WORD		V1-LA2...302	°C/°F
V1	V1-LA2	36262	43806.6	RW	Probe 2 minimum alarm	WORD		-58.0...V1-HA2	°C/°F
V1	V1-PAO	36264	43807	RW	Exclude alarm at switch on	WORD		0...10	hours
V1	V1-dAO	36268	43807.2	RW	Exclude alarm after defrost	WORD		0...250	min
V1	V1-OAO	36266	43807.4	RW	Alarm signal delay after closing door	WORD		0...10	hours
V1	V1-tdO	36356	43807.6	RW	Open door disabling time	WORD		0...250	num
V1	V1-tA1	36270	43808	RW	LA1 and HA1 alarm signal delay	WORD		0...250	min
V1	V1-tA2	36272	43808.2	RW	LA2 and HA2 alarm signal delay	WORD		0...250	min
V1	V1-dAt	36188	43808.4	RW	Enable alarm at end of defrost	WORD		0/1	num



FOLDER	LABEL	PAR. ADDRESS VALUE	PAR. ADDRESS Vis.	R/W	DESCRIPTION	DATA SIZE	CPL	RANGE	UM
V1	V1-EAL	36276	43808.6	RW	External alarm switches off utilities	WORD		0/1/2	num
V1	V1-tP	36358	43809	RW	Enable alarm overriding from any key	WORD		0/1	num
V1	V1-Art	36246	43809.2	RW	Alarm activation period supervisor link	WORD		0...250	min*10
V1	V1-dSd	36240	43809.4	RW	Enable light relay from door switch	WORD		0/1	num
V1	V1-dLt	36242	43809.6	RW	Delay disabling light relay	WORD		0...250	min
V1	V1-OFL	36244	43810	RW	Light key always disables light relay	WORD		0/1	num
V1	V1-dOd	36274	43810.2	RW	Door switch turns off utilities	WORD		0...3	num
V1	V1-dOA	36278	43810.4	RW	Action forced by digital input	WORD		0...5	num
V1	V1-PEA	36280	43810.6	RW	DI selected to block/release resources	WORD		0...3	num
V1	V1-dCO	36282	43811	RW	Delay to activate/switch off compressor evap. fan	WORD		0...250	min
V1	V1-dFO	36284	43811.2	RW	Delay to activate/switch off evap. fan	WORD		0...250	min
V1	V1-ASb	36336	43811.4	RW	Key/AUX input/Light active when OFF	WORD		0/1	num
V1	V1-L00	35840	43811.6	RW	Shared probe	WORD		0...6	num
V1	V1-L01	35842	43812	RW	Display value shared	WORD		0/1/2	num
V1	V1-L02	35844	43812.2	RW	Send setpoint value when modified	WORD		0/1	num
V1	V1-L03	35846	43812.4	RW	Send defrost request	WORD		0/1	num
V1	V1-L04	35848	43812.6	RW	End defrost mode	WORD		0/1	num
V1	V1-L05	35850	43813	RW	Synchronization of Stand-By command	WORD		0/1	num
V1	V1-L06	35852	43813.2	RW	Synchronization of light command	WORD		0/1	num
V1	V1-L07	35854	43813.4	RW	Synchronization of reduced setpoint command	WORD		0/1	num
V1	V1-L08	35856	43813.6	RW	Synchronization of AUX command	WORD		0/1	num
V1	V1-L10	36360	43814.2	RW	Wait for end of dependent defrost timeout	WORD		0...250	min
V1	V1-PEn	36236	43814.4	RW	Number of errors allowed	WORD		0...15	num
V1	V1-PEi	36238	43814.6	RW	Error count interval	WORD		1...250	min
V1	V1-dcS	36228	43815	RW	Deep Cooling Setpoint	WORD		-58.0...302	°C/°F
V1	V1-tdc	36230	43815.2	RW	Deep Cooling duration	WORD		0...250	min
V1	V1-dcc	36232	43815.4	RW	Waiting time to start defrost cycle	WORD		0...250	min
V1	V1-ESt	36086	43815.6	RW	Type of Energy Saving	WORD		0...4	num
V1	V1-ESF	36222	43816	RW	Night mode enabled	WORD		0/1	num
V1	V1-Cdt	36224	43816.2	RW	Min. door closed time to activate reduced setpoint	WORD		0...255	min*10
V1	V1-ESo	36226	43816.4	RW	Cumulative door open time	WORD		0...10	num
V1	V1-OS1	36120	43816.6	RW	Offset SP1	WORD		-50.0...50.0	°C/°F
V1	V1-OS2	36122	43817	RW	Offset SP2	WORD		-50.0...50.0	°C/°F
V1	V1-Od1	36124	43817.2	RW	Door energy saving offset 1	WORD		-50.0...50.0	°C/°F
V1	V1-Od2	36126	43817.4	RW	Door energy saving offset 2	WORD		-50.0...50.0	°C/°F
V1	V1-dn1	36102	43817.6	RW	dn1 Differential in energy saving mode 1	WORD		-58.0...302	°C/°F
V1	V1-dn2	36104	43818	RW	dn2 Differential in energy saving mode 2	WORD		-58.0...302	°C/°F
V1	V1-EdH	36074	43818.2	RW	Start time weekday Energy Saving	WORD		0...24	hours
V1	V1-Edn	36076	43818.4	RW	Weekday Energy Saving start time minutes	WORD		0...59	min
V1	V1-	36078	43818.6	RW	Weekday Energy Saving event duration	WORD		1...72	hours
V1	V1-EFH	36080	43819	RW	Weekend/public holiday Energy Saving start time	WORD		0...24	hours
V1	V1-EFn	36082	43819.2	RW	Weekend/public holiday Energy Saving start time minutes	WORD		0...59	min
V1	V1-EFd	36084	43819.4	RW	Weekend/public holiday Energy Saving event duration	WORD		1...72	hours
V1	V1-FH	36286	43819.6	RW	Regulation mode	WORD		0...7	num
V1	V1-FHt	36290	43820	RW	Frame heater period	WORD		1...2500	sec*10
V1	V1-FH0	36292	43820.2	RW	Frame heater setpoint	WORD		-58.0...302	°C/°F
V1	V1-FH1	36294	43820.4	RW	Frame heater offset	WORD		0.0...25.0	°C/°F
V1	V1-FH2	36296	43820.6	RW	Frame heater band	WORD		0.0...25.0	°C/°F
V1	V1-FH3	36298	43821	RW	Min. percentage	WORD		0...100	%
V1	V1-FH4	36300	43821.2	RW	Maximum percentage/Duty Cycle Day	WORD		0...100	%
V1	V1-FH5	36302	43821.4	RW	Maximum percentage/Duty Cycle Night (ES)	WORD		0...100	%
V1	V1-FH6	36304	43821.6	RW	Percentage during defrost	WORD		0...100	%
V1	V1-LOC	36310	43822	RW	Keypad lock	WORD		0/1	num
V1	V1-PS1	36312	43822.2	RW	Password 1	WORD		0...250	num
V1	V1-PS2	36314	43822.4	RW	Password 2	WORD		0...250	num
V1	V1-ndt	36316	43822.6	RW	Display with decimal point	WORD		0/1	num



FOLDER	LABEL	PAR. ADDRESS VALUE	PAR. ADDRESS Vis.	R/W	DESCRIPTION	DATA SIZE	CPL	RANGE	UM
V1	V1-CA1	35928	43823	RW	Calibration ST1	WORD		-30.0...30.0	°C/°F
V1	V1-CA2	35930	43823.2	RW	Calibration ST2	WORD		-30.0...30.0	°C/°F
V1	V1-CA3	35932	43823.4	RW	Calibration ST3	WORD		-30.0...30.0	°C/°F
V1	V1-CA4	35934	43823.6	RW	Calibration ST4	WORD		-30.0...30.0	°C/°F
V1	V1-CA5	35936	43824	RW	Calibration ST5	WORD		-30.0...30.0	°C/°F
V1	V1-LdL	36318	43824.6	RW	Minimum value displayable	WORD		-58.0...V1-HdL	°C/°F
V1	V1-HdL	36320	43825	RW	Maximum value displayable	WORD		V1-LdL...302	°C/°F
V1	V1-ddL	36322	43825.2	RW	Block display during defrost	WORD		0/1/2	num
V1	V1-Ldd	36324	43825.4	RW	"ddL" Release Time-Out	WORD		0...250	min
V1	V1-dro	36326	43825.6	RW	°C/°F selection (0=°C, 1=°F)	WORD		0/1	num
V1	V1-ddd	36330	43826.2	RW	Main Display	WORD		0...7	num
V1	V1-ddE	36332	43826.4	RW	Main display on ECHO	WORD		0...7	num
V1	V1-rPH	36234	43826.6	RW	Select HACCP alarm probe	WORD		0...5	num
V1	V1-H00	35860	43827	RW	Type of probe ST1-ST2-ST3-ST4-ST5 (0=NTC, 1=PTC, 2=PT1000)	WORD		0/1/2	num
V1	V1-H02	36334	43827.2	RW	Key activation time	WORD		0...250	sec
V1	V1-H08	36338	43827.4	RW	Stand-By mode	WORD		0/1/2	num
V1	V1-H11	35870	43827.6	RW	Configuration input DI1	WORD		-17...17	num
V1	V1-H12	35872	43828	RW	Configuration input DI2	WORD		-17...17	num
V1	V1-H13	35874	43828.2	RW	Configuration input DI3	WORD		-17...17	num
V1	V1-H14	35876	43828.4	RW	Configuration input DI4	WORD		-17...17	num
V1	V1-H15	35878	43828.6	RW	Configuration input DI5	WORD		-17...17	num
V1	V1-H16	35880	43829	RW	Configuration input DI6	WORD		-17...17	num
V1	V1-H17	35882	43829.2	RW	Configuration input DI7	WORD		-17...17	num
V1	V1-H18	35884	43829.4	RW	Configuration input DI8	WORD		-17...17	num
V1	V1-dti	35902	43829.6	RW	Unit of measure for digital inputs 1 and 2	WORD		0/1	num
V1	V1-d11	35886	43830	RW	Activation delay for digital input 1	WORD		0...255	min/sec
V1	V1-d12	35888	43830.2	RW	Activation delay for digital input 2	WORD		0...255	min/sec
V1	V1-d13	35890	43830.4	RW	Activation delay for digital input 3	WORD		0...255	min
V1	V1-d14	35892	43830.6	RW	Activation delay for digital input 4	WORD		0...255	min
V1	V1-d15	35894	43831	RW	Activation delay for digital input 5	WORD		0...255	min
V1	V1-d16	35896	43831.2	RW	Activation delay for digital input 6	WORD		0...255	min
V1	V1-d17	35898	43831.4	RW	Activation delay for digital input 7	WORD		0...255	min
V1	V1-d18	35900	43831.6	RW	Activation delay for digital input 8	WORD		0...255	min
V1	V1-H21	35944	43832	RW	Configuration Relay 1	WORD		0...13	num
V1	V1-H22	35946	43832.2	RW	Configuration Relay 2	WORD		0...13	num
V1	V1-H23	35948	43832.4	RW	Configuration Relay 3	WORD		0...13	num
V1	V1-H24	35950	43832.6	RW	Configuration Relay 4	WORD		0...13	num
V1	V1-H25	35952	43833	RW	Configuration Relay 5	WORD		0...13	num
V1	V1-H26	35954	43833.2	RW	Configuration Relay 6	WORD		0...13	num
V1	V1-H27	35956	43833.4	RW	Configuration Relay 7	WORD		0...13	num
V1	V1-H29	35958	43833.6	RW	Enable buzzer	WORD		0/1	num
V1	V1-H31	36340	43834	RW	Configuration of UP key	WORD		0...8	num
V1	V1-H32	36342	43834.2	RW	Configuration of DOWN key	WORD		0...8	num
V1	V1-H33	36344	43834.4	RW	ESC key configuration	WORD		0...8	num
V1	V1-H41	35904	43835.6	RW	Configuration input ST1 (0=Disable, 1=DI, 2=H00)	WORD		0/1/2	num
V1	V1-H42	35906	43836	RW	Configuration input ST2 (0=Disable, 1=DI, 2=H00)	WORD		0/1/2	num
V1	V1-H43	35908	43836.2	RW	Configuration input ST3 (0=Disable, 1=DI, 2=H00)	WORD		0/1/2	num
V1	V1-H44	35910	43836.4	RW	Configuration input ST4 (0=Disable, 1=DI, 2=H00)	WORD		0/1/2	num
V1	V1-H45	35912	43836.6	RW	Configuration input ST5 (0=Disable, 1=DI, 2=H00)	WORD		0/1/2	num
V1	V1-H50	35960	43837.4	RW	Configuration Type of Analogue Output	WORD		0/1	num
V1	V1-H51	35962	43837.6	RW	Regulator associated to analogue output	WORD		0/1	num
V1	V1-H68	35964	43838	RW	Clock Present	WORD		0/1	num
V1	V1-H70	35920	43838.2	RW	Select probe 1 for virtual probe	WORD		0...5	num
V1	V1-H71	35922	43838.4	RW	Select probe 2 for virtual probe	WORD		0...5	num
V1	V1-H72	35924	43838.6	RW	% calculation virtual probe day	WORD		0...100	%
V1	V1-H73	35926	43839	RW	% calculation virtual probe night	WORD		0...100	%



FOLDER	LABEL	PAR. ADDRESS VALUE	PAR. ADDRESS Vis.	R/W	DESCRIPTION	DATA SIZE	CPL	RANGE	UM
V1	V1-UL	---	43588	RW	Parameter transfer function visibility (Device -> Copy Card)	2 BIT		0...3	num
V1	V1-dL	---	43588.2	RW	Parameter transfer function visibility (Copy Card -> Device)	2 BIT		0...3	num
V1	V1-Fr	---	43588.4	RW	Format Copy Card function visibility	2 BIT		0...3	num
<b>APPLICATION 2 PARAMETERS</b>									
	V2-SP1	36862	43968.6	RW	Setpoint	WORD		V2-LS1...V2-HS1	°C/°F
	V2-SP2	36866	43969.2	RW	Thermostat 2 setpoint	WORD		V2-LS2...V2-HS2	°C/°F
V2	V2-rE	36856	43968	RW	Regulation mode	WORD		0...4	num
V2	V2-rP1	36858	43968.2	RW	Regulation probe 1	WORD		0...7	num
V2	V2-rP2	36860	43968.4	RW	Thermostat 2 regulation probe	WORD		0...7	num
V2	V2-dF1	36864	43969	RW	Differential/proportional band	WORD		-58.0...302	°C/°F
V2	V2-dF2	36868	43969.4	RW	Thermostat 2 differential	WORD		-58.0...302	°C/°F
V2	V2-Stt	36874	43969.6	RW	Differential control mode	WORD		0/1	num
V2	V2-HS1	36880	43970	RW	SP1 maximum value	WORD		V2-LS1...V2-HdL	°C/°F
V2	V2-LS1	36882	43970.2	RW	SP1 minimum value	WORD		V2-LdL...V2-HS1	°C/°F
V2	V2-HS2	36884	43970.4	RW	SP2 maximum value	WORD		V2-LS2...V2-HdL	°C/°F
V2	V2-LS2	36886	43970.6	RW	SP2 minimum value	WORD		V2-LdL...V2-HS2	°C/°F
V2	V2-HC1	36876	43971	RW	Thermostat 1 mode	WORD		0/1	num
V2	V2-HC2	36878	43971.2	RW	Thermostat 2 mode	WORD		0/1	num
V2	V2-CC	36916	43971.4	RW	Double power step control	WORD		0/1	num
V2	V2-Cit	36896	43971.6	RW	Minimum compressor ON time	WORD		0...250	min
V2	V2-CAt	36898	43972	RW	Maximum compressor ON time	WORD		0...250	min
V2	V2-Ont	36908	43972.2	RW	ON time for faulty probe	WORD		0...250	min
V2	V2-OfT	36910	43972.4	RW	OFF time for faulty probe	WORD		0...250	min
V2	V2-dOn	36900	43972.6	RW	Switch on delay	WORD		0...250	sec
V2	V2-dOF	36902	43973	RW	Delay after switching off	WORD		0...250	min
V2	V2-dbi	36904	43973.2	RW	Delay between switch-ons	WORD		0...250	min
V2	V2-OdO	36906	43973.4	RW	Output delay from power-on	WORD		0...250	min
V2	V2-CP2	36912	43973.6	RW	Compressor 2 switch-on delay	WORD		0...250	sec
V2	V2-CS2	36914	43974	RW	Power step 2 switch-on delay	WORD		0...250	min
V2	V2-CFP	37074	43974.2	RW	Preventilation time	WORD		0...255	sec
V2	V2-CFd	37076	43974.4	RW	Fan mode	WORD		0/1	num
V2	V2-OF1	36918	43974.6	RW	Forced remote offset	WORD		-50.0...50.0	°C/°F
V2	V2-dP1	36920	43975	RW	Selection defrost probe 1	WORD		0...7	num
V2	V2-dP2	36922	43975.2	RW	Selection defrost probe 2	WORD		0...7	num
V2	V2-dtY	36928	43975.4	RW	Defrost mode	WORD		0...4	num
V2	V2-dFt	36924	43975.6	RW	Defrost activation mode with two probes	WORD		0/1/2	num
V2	V2-dit	36930	43976	RW	Interval between defrost cycles	WORD		0...250	hours
V2	V2-dt1	36936	43976.2	RW	Unit of measurement for defrost interval	WORD		0/1/2	num
V2	V2-dt2	36938	43976.4	RW	Unit of measure for defrost duration	WORD		0/1/2	num
V2	V2-dCt	36926	43976.6	RW	Defrost interval count mode	WORD		0...5	num
V2	V2-dOH	36940	43977	RW	Defrost interval count mode	WORD		0...250	min
V2	V2-dE1	36932	43977.2	RW	Evaporator 1 defrost time-out	WORD		1...250	min
V2	V2-dE2	36934	43977.4	RW	Evaporator 2 defrost time-out	WORD		1...250	min
V2	V2-dS1	36944	43977.6	RW	Probe 1 end of defrost temperature	WORD		-58.0...302	°C/°F
V2	V2-dS2	36946	43978	RW	Probe 2 end of defrost temperature	WORD		-58.0...302	°C/°F
V2	V2-dSS	36942	43978.2	RW	Start defrost temperature threshold	WORD		-58.0...302	°C/°F
V2	V2-dPO	36948	43978.4	RW	Request defrost activation from power on	WORD		0/1	num
V2	V2-tcd	36950	43978.6	RW	Min. compressor ON or OFF time before defrost	WORD		-60...60	min
V2	V2-ndE	36952	43979	RW	Minimum defrost time (for hot gas only)	WORD		0...250	min
V2	V2-PdC	36954	43979.2	RW	Hot gas extraction time at defrost end	WORD		0...250	min
V2	V2-tPd	36958	43979.4	RW	Pump down time before defrost startup	WORD		0...255	min
V2	V2-dPH	36836	43979.6	RW	Start time for periodical defrost	WORD		0...24	hours
V2	V2-dPn	36838	43980	RW	Start time minutes for periodical defrost	WORD		0...59	min
V2	V2-dPd	36840	43980.2	RW	Periodical defrost interval duration	WORD		1...7	Day
V2	V2-Fd1	36734	43980.4	RW	Weekend/public holiday 1	WORD		0...7	num



FOLDER	LABEL	PAR. ADDRESS VALUE	PAR. ADDRESS Vis.	R/W	DESCRIPTION	DATA SIZE	CPL	RANGE	UM
V2	V2-Fd2	36736	43980.6	RW	Weekend/public holiday 2	WORD		0..7	num
V2	V2-Edt	36738	43981	RW	Customized duration and temperature for each event	WORD		0/1	num
V2	V2-d1H	36740	43981.2	RW	Start time weekday defrost 1	WORD		0..24	hours
V2	V2-d1n	36742	43981.4	RW	Start time minutes weekday defrost 1	WORD		0..59	min
V2	V2-d1t	36744	43981.6	RW	Weekday defrost 1 duration	WORD		0..250	min
V2	V2-d1S	36746	43982	RW	End of weekday defrost 1 temperature	WORD		-58.0...302	°C/°F
V2	V2-d2H	36748	43982.2	RW	Start time weekday defrost 2	WORD		V2-d1H...24	hours
V2	V2-d2n	36750	43982.4	RW	Start time minutes weekday defrost 2	WORD		0..59	min
V2	V2-d2t	36752	43982.6	RW	Weekday defrost 2 duration	WORD		0..250	min
V2	V2-d2S	36754	43983	RW	End of weekday defrost 2 temperature	WORD		-58.0...302	°C/°F
V2	V2-d3H	36756	43983.2	RW	Start time weekday defrost 3	WORD		V2-d2H...24	hours
V2	V2-d3n	36758	43983.4	RW	Start time minutes weekday defrost 3	WORD		0..59	min
V2	V2-d3t	36760	43983.6	RW	Weekday defrost 3 duration	WORD		0..250	min
V2	V2-d3S	36762	43984	RW	End of weekday defrost 3 temperature	WORD		-58.0...302	°C/°F
V2	V2-d4H	36764	43984.2	RW	Start time weekday defrost 4	WORD		V2-d3H...24	hours
V2	V2-d4n	36766	43984.4	RW	Start time minutes weekday defrost 4	WORD		0..59	min
V2	V2-d4t	36768	43984.6	RW	Weekday defrost 4 duration	WORD		0..250	min
V2	V2-d4S	36770	43985	RW	End of weekday defrost 4 temperature	WORD		-58.0...302	°C/°F
V2	V2-d5H	36772	43985.2	RW	Start time weekday defrost 5	WORD		V2-d4H...24	hours
V2	V2-d5n	36774	43985.4	RW	Start time minutes weekday defrost 5	WORD		0..59	min
V2	V2-d5t	36776	43985.6	RW	Weekday defrost 5 duration	WORD		0..250	min
V2	V2-d5S	36778	43986	RW	End of weekday defrost 5 temperature	WORD		-58.0...302	°C/°F
V2	V2-d6H	36780	43986.2	RW	Start time weekday defrost 6	WORD		V2-d5H...24	hours
V2	V2-d6n	36782	43986.4	RW	Start time minutes weekday defrost 6	WORD		0..59	min
V2	V2-d6t	36784	43986.6	RW	Weekday defrost 6 duration	WORD		0..250	min
V2	V2-d6S	36786	43987	RW	End of weekday defrost 6 temperature	WORD		-58.0...302	°C/°F
V2	V2-F1H	36788	43987.2	RW	Start time weekend/public holiday defrost 1	WORD		0..24	hours
V2	V2-F1n	36790	43987.4	RW	Weekend/public holiday defrost 1 start time minutes	WORD		0..59	min
V2	V2-F1t	36792	43987.6	RW	Weekend/public holiday defrost 1 duration	WORD		0..250	min
V2	V2-F1S	36794	43988	RW	End of weekend/public holiday defrost 1 temperature	WORD		-58.0...302	°C/°F
V2	V2-F2H	36796	43988.2	RW	Start time weekend/public holiday defrost 2	WORD		V2-F1H...24	hours
V2	V2-F2n	36798	43988.4	RW	Weekend/public holiday defrost 2 start time minutes	WORD		0..59	min
V2	V2-F2t	36800	43988.6	RW	Weekend/public holiday defrost 2 duration	WORD		0..250	min
V2	V2-F2S	36802	43989	RW	End of weekend/public holiday defrost 1 temperature	WORD		-58.0...302	°C/°F
V2	V2-F3H	36804	43989.2	RW	Start time weekend/public holiday defrost 3	WORD		V2-F2H...24	hours
V2	V2-F3n	36806	43989.4	RW	Weekend/public holiday defrost 3 start time minutes	WORD		0..59	min
V2	V2-F3t	36808	43989.6	RW	Weekend/public holiday defrost 3 duration	WORD		0..250	min
V2	V2-F3S	36810	43990	RW	End of weekend/public holiday defrost 1 temperature	WORD		-58.0...302	°C/°F
V2	V2-F4H	36812	43990.2	RW	Start time weekend/public holiday defrost 4	WORD		V2-F3H...24	hours
V2	V2-F4n	36814	43990.4	RW	Weekend/public holiday defrost 4 start time minutes	WORD		0..59	min
V2	V2-F4t	36816	43990.6	RW	Weekend/public holiday defrost 4 duration	WORD		0..250	min
V2	V2-F4S	36818	43991	RW	End of weekend/public holiday defrost 1 temperature	WORD		-58.0...302	°C/°F
V2	V2-F5H	36820	43991.2	RW	Start time weekend/public holiday defrost 5	WORD		V2-F4H...24	hours
V2	V2-F5n	36822	43991.4	RW	Weekend/public holiday defrost 5 start time minutes	WORD		0..59	min
V2	V2-F5t	36824	43991.6	RW	Weekend/public holiday defrost 5 duration	WORD		0..250	min
V2	V2-F5S	36826	43992	RW	End of weekend/public holiday defrost 1 temperature	WORD		-58.0...302	°C/°F
V2	V2-F6H	36828	43992.2	RW	Start time weekend/public holiday defrost 6	WORD		V2-F5H...24	hours
V2	V2-F6n	36830	43992.4	RW	Weekend/public holiday defrost 6 start time minutes	WORD		0..59	min
V2	V2-F6t	36832	43992.6	RW	Weekend/public holiday defrost 6 duration	WORD		0..250	min
V2	V2-F6S	36834	43993	RW	End of weekend/public holiday defrost 6 temperature	WORD		-58.0...302	°C/°F
V2	V2-FP1	36960	43993.2	RW	Evaporator fan probe in normal mode	WORD		0..7	num
V2	V2-FP2	36962	43993.4	RW	Evaporator fan probe during defrost stage	WORD		0..7	num
V2	V2-FPt	36964	43993.6	RW	FSt parameter mode	WORD		0/1	num
V2	V2-FSt	36966	43994	RW	Block fan temperature	WORD		-58.0...302	°C/°F
V2	V2-FAd	36968	43994.2	RW	Fan differential	WORD		0.1...25.0	°C/°F
V2	V2-Fdt	36970	43994.4	RW	Fan activation delay after compressor start	WORD		0..250	min



FOLDER	LABEL	PAR. ADDRESS VALUE	PAR. ADDRESS Vis.	R/W	DESCRIPTION	DATA SIZE	CPL	RANGE	UM
V2	V2-dt	36980	43994.6	RW	Dripping time	WORD		0...250	min
V2	V2-dFd	36976	43995	RW	Evaporator fan mode during defrost	WORD		0/1	num
V2	V2-FCO	36974	43995.2	RW	Evaporator fan mode	WORD		0...3	num
V2	V2-FdC	36972	43995.6	RW	Fan switch off delay after compressor stop	WORD		0...250	min
V2	V2-FOn	36982	43996	RW	Fan ON time in Duty Cycle	WORD		0...250	min
V2	V2-FOF	36984	43996.2	RW	Fan OFF time in Duty Cycle	WORD		0...250	min
V2	V2-Fnn	36986	43996.4	RW	Duty cycle on time during night mode	WORD		0...250	min
V2	V2-FnF	36988	43996.6	RW	Duty cycle off time during night mode	WORD		0...250	min
V2	V2-rA1	37016	43997	RW	Temperature alarm probe 1 selection	WORD		0...6	num
V2	V2-rA2	37018	43997.2	RW	Temperature alarm probe 2 selection	WORD		0...6	num
V2	V2-Att	37020	43997.4	RW	Parameter HAL and LAL mode	WORD		0/1	num
V2	V2-AFd	37022	43997.6	RW	Alarm setpoint differential	WORD		0.1...25.0	°C/°F
V2	V2-HA1	37024	43998	RW	Probe 1 maximum alarm	WORD		V2-LA1...302	°C/°F
V2	V2-LA1	37026	43998.2	RW	Probe 1 minimum alarm	WORD		-58,0...V2-HA1	°C/°F
V2	V2-HA2	37028	43998.4	RW	Probe 2 maximum alarm	WORD		V2-LA2...302	°C/°F
V2	V2-LA2	37030	43998.6	RW	Probe 2 minimum alarm	WORD		-58,0...V2-HA2	°C/°F
V2	V2-PAO	37032	43999	RW	Exclude alarm at switch on	WORD		0...10	hours
V2	V2-dAO	37036	43999.2	RW	Exclude alarm after defrost	WORD		0...250	min
V2	V2-OAO	37034	43999.4	RW	Alarm signal delay after closing door	WORD		0...10	hours
V2	V2-tdO	37124	43999.6	RW	Open door disabling time	WORD		0...250	num
V2	V2-tA1	37038	44000	RW	LA1 and HA1 alarm signal delay	WORD		0...250	min
V2	V2-tA2	37040	44000.2	RW	LA2 and HA2 alarm signal delay	WORD		0...250	min
V2	V2-dAt	36956	44000.4	RW	Enable alarm at end of defrost	WORD		0/1	num
V2	V2-EAL	37044	44000.6	RW	External alarm switches off utilities	WORD		0...2	num
V2	V2-tP	37126	44001	RW	Enable alarm overriding from any key	WORD		0/1	num
V2	V2-Art	37014	44001.2	RW	Alarm activation period supervisor link	WORD		0...250	min*10
V2	V2-dSd	37008	44001.4	RW	Enable light relay from door switch	WORD		0/1	num
V2	V2-dLt	37010	44001.6	RW	Delay disabling light relay	WORD		0...250	min
V2	V2-OFL	37012	44002	RW	Light key always disables light relay	WORD		0/1	num
V2	V2-dOd	37042	44002.2	RW	Door switch turns off utilities	WORD		0...3	num
V2	V2-dOA	37046	44002.4	RW	Action forced by digital input	WORD		0...5	num
V2	V2-PEA	37048	44002.6	RW	DI selected to block/release resources	WORD		0...3	num
V2	V2-dCO	37050	44003	RW	Delay to activate/switch off compressor evap. fan	WORD		0...250	min
V2	V2-dFO	37052	44003.2	RW	Delay to activate/switch off evap. fan	WORD		0...250	min
V2	V2-ASb	37104	44003.4	RW	Key/AUX input/Light active when OFF	WORD		0/1	num
V2	V2-L00	36608	44003.6	RW	Shared probe	WORD		0...6	num
V2	V2-L01	36610	44004	RW	Display value shared	WORD		0/1/2	num
V2	V2-L02	36612	44004.2	RW	Send setpoint value when modified	WORD		0/1	num
V2	V2-L03	36614	44004.4	RW	Send defrost request	WORD		0/1	num
V2	V2-L04	36616	44004.6	RW	End defrost mode	WORD		0/1	num
V2	V2-L05	36618	44005	RW	Synchronization of Stand-By command	WORD		0/1	num
V2	V2-L06	36620	44005.2	RW	Synchronization of light command	WORD		0/1	num
V2	V2-L07	36622	44005.4	RW	Synchronization of reduced setpoint command	WORD		0/1	num
V2	V2-L08	36624	44005.6	RW	Synchronization of AUX command	WORD		0/1	num
V2	V2-L10	37128	44006.2	RW	Wait for end of dependent defrost timeout	WORD		0...250	min
V2	V2-PEn	37004	44006.4	RW	Number of errors allowed	WORD		0...15	num
V2	V2-PEi	37006	44006.6	RW	Error count interval	WORD		1...250	min
V2	V2-dcS	36996	44007	RW	Deep Cooling Setpoint	WORD		-58.0...302	°C/°F
V2	V2-tdc	36998	44007.2	RW	Deep Cooling duration	WORD		0...250	min
V2	V2-dcc	37000	44007.4	RW	Waiting time to start defrost cycle	WORD		0...250	min
V2	V2-ESt	36854	44007.6	RW	Type of Energy Saving	WORD		0...4	num
V2	V2-ESF	36990	44008	RW	Night mode enabled	WORD		0/1	num
V2	V2-Cdt	36992	44008.2	RW	Min. door closed time to activate reduced setpoint	WORD		0...255	min*10
V2	V2-ESo	36994	44008.4	RW	Cumulative door open time	WORD		0...10	num
V2	V2-OS1	36888	44008.6	RW	Offset SP1	WORD		-50.0...50.0	°C/°F
V2	V2-OS2	36890	44009	RW	Offset SP2	WORD		-50.0...50.0	°C/°F



FOLDER	LABEL	PAR. ADDRESS VALUE	PAR. ADDRESS Vis.	R/W	DESCRIPTION	DATA SIZE	CPL	RANGE	UM
V2	V2-Od1	36892	44009.2	RW	Door energy saving offset 1	WORD		-50.0...50.0	°C/°F
V2	V2-Od2	36894	44009.4	RW	Door energy saving offset 2	WORD		-50.0...50.0	°C/°F
V2	V2-dn1	36870	44009.6	RW	dn1 Differential in energy saving mode 1	WORD		-58.0...302	°C/°F
V2	V2-dn2	36872	44010	RW	dn2 Differential in energy saving mode 2	WORD		-58.0...302	°C/°F
V2	V2-EdH	36842	44010.2	RW	Start time weekday Energy Saving	WORD		0...24	hours
V2	V2-Edn	36844	44010.4	RW	Weekday Energy Saving start time minutes	WORD		0...59	min
V2	V2-Edd	36846	44010.6	RW	Weekday Energy Saving event duration	WORD		1...72	hours
V2	V2-EFH	36848	44011	RW	Weekend/public holiday Energy Saving start time	WORD		0...24	hours
V2	V2-EFn	36850	44011.2	RW	Weekend/public holiday Energy Saving start time minutes	WORD		0...59	min
V2	V2-EFd	36852	44011.4	RW	Weekend/public holiday Energy Saving event duration	WORD		1...72	hours
V2	V2-FH	37054	44011.6	RW	Regulation mode	WORD		0...7	num
V2	V2-FHt	37058	44012	RW	Frame heater period	WORD		1...2500	sec*10
V2	V2-FH0	37060	44012.2	RW	Frame heater setpoint	WORD		-58.0...302	°C/°F
V2	V2-FH1	37062	44012.4	RW	Frame heater offset	WORD		0.0...25.0	°C/°F
V2	V2-FH2	37064	44012.6	RW	Frame heater band	WORD		0.0...25.0	°C/°F
V2	V2-FH3	37066	44013	RW	Min. percentage	WORD		0...100	%
V2	V2-FH4	37068	44013.2	RW	Maximum percentage/Duty Cycle Day	WORD		0...100	%
V2	V2-FH5	37070	44013.4	RW	Maximum percentage/Duty Cycle Night (ES)	WORD		0...100	%
V2	V2-FH6	37072	44013.6	RW	Percentage during defrost	WORD		0...100	%
V2	V2-LOC	37078	44014	RW	Keypad lock	WORD		0/1	num
V2	V2-PS1	37080	44014.2	RW	Password 1	WORD		0...250	num
V2	V2-PS2	37082	44014.4	RW	Password 2	WORD		0...250	num
V2	V2-ndt	37084	44014.6	RW	Display with decimal point	WORD		0/1	num
V2	V2-CA1	36696	44015	RW	Calibration Pb1	WORD		-30.0...30.0	°C/°F
V2	V2-CA2	36698	44015.2	RW	Calibration Pb2	WORD		-30.0...30.0	°C/°F
V2	V2-CA3	36700	44015.4	RW	Calibration Pb3	WORD		-30.0...30.0	°C/°F
V2	V2-CA4	36702	44015.6	RW	Calibration Pb4	WORD		-30.0...30.0	°C/°F
V2	V2-CA5	36704	44016	RW	Calibration Pb5	WORD		-30.0...30.0	°C/°F
V2	V2-LdL	37086	44016.6	RW	Minimum value displayable	WORD		-58.0...V2-HdL	°C/°F
V2	V2-HdL	37088	44017	RW	Maximum value displayable	WORD		V2-LdL...302	°C/°F
V2	V2-ddL	37090	44017.2	RW	Block display during defrost	WORD		0/1/2	num
V2	V2-Ldd	37092	44017.4	RW	"ddL" Release Time-Out	WORD		0...250	min
V2	V2-dro	37094	44017.6	RW	°C/°F selection (0=°C, 1=°F)	WORD		0/1	num
V2	V2-ddd	37098	44018.2	RW	Main Display	WORD		0...7	num
V2	V2-ddE	37100	44018.4	RW	Main display on ECHO	WORD		0...7	num
V2	V2-rPH	37002	44018.6	RW	Select HACCP alarm probe	WORD		0...5	num
V2	V2-H00	36628	44019	RW	Type of probe Pb1-Pb2-Pb3-Pb4-Pb5 (0=NTC, 1=PTC, 2=PT1000)	WORD		0/1/2	num
V2	V2-H02	37102	44019.2	RW	Key activation time	WORD		0...250	sec
V2	V2-H08	37106	44019.4	RW	Stand-By mode	WORD		0/1/2	num
V2	V2-H11	36638	44019.6	RW	Configuration input DI1	WORD		-17...17	num
V2	V2-H12	36640	44020	RW	Configuration input DI2	WORD		-17...17	num
V2	V2-H13	36642	44020.2	RW	Configuration input DI3	WORD		-17...17	num
V2	V2-H14	36644	44020.4	RW	Configuration input DI4	WORD		-17...17	num
V2	V2-H15	36646	44020.6	RW	Configuration input DI5	WORD		-17...17	num
V2	V2-H16	36648	44021	RW	Configuration input DI6	WORD		-17...17	num
V2	V2-H17	36650	44021.2	RW	Configuration input DI7	WORD		-17...17	num
V2	V2-H18	36652	44021.4	RW	Configuration input DI8	WORD		-17...17	num
V2	V2-dti	36670	44021.6	RW	Unit of measure for digital inputs 1 and 2	WORD		0/1	num
V2	V2-d11	36654	44022	RW	Activation delay for digital input 1	WORD		0...255	min/sec
V2	V2-d12	36656	44022.2	RW	Activation delay for digital input 2	WORD		0...255	min/sec
V2	V2-d13	36658	44022.4	RW	Activation delay for digital input 3	WORD		0...255	min
V2	V2-d14	36660	44022.6	RW	Activation delay for digital input 4	WORD		0...255	min
V2	V2-d15	36662	44023	RW	Activation delay for digital input 5	WORD		0...255	min
V2	V2-d16	36664	44023.2	RW	Activation delay for digital input 6	WORD		0...255	min
V2	V2-d17	36666	44023.4	RW	Activation delay for digital input 7	WORD		0...255	min
V2	V2-d18	36668	44023.6	RW	Activation delay for digital input 8	WORD		0...255	min



FOLDER	LABEL	PAR. ADDRESS VALUE	PAR. ADDRESS Vis.	R/W	DESCRIPTION	DATA SIZE	CPL	RANGE	UM
V2	V2-H21	36712	44024	RW	Configuration Relay 1	WORD		0...13	num
V2	V2-H22	36714	44024.2	RW	Configuration Relay 2	WORD		0...13	num
V2	V2-H23	36716	44024.4	RW	Configuration Relay 3	WORD		0...13	num
V2	V2-H24	36718	44024.6	RW	Configuration Relay 4	WORD		0...13	num
V2	V2-H25	36720	44025	RW	Configuration Relay 5	WORD		0...13	num
V2	V2-H26	36722	44025.2	RW	Configuration Relay 6	WORD		0...13	num
V2	V2-H27	36724	44025.4	RW	Configuration Relay 7	WORD		0...13	num
V2	V2-H29	36726	44025.6	RW	Enable buzzer	WORD		0/1	num
V2	V2-H31	37108	44026	RW	Configuration of UP key	WORD		0...8	num
V2	V2-H32	37110	44026.2	RW	Configuration of DOWN key	WORD		0...8	num
V2	V2-H33	37112	44026.4	RW	ESC key configuration	WORD		0...8	num
V2	V2-H41	36672	44027.6	RW	Configuration input Pb1 (0=Disable, 1=DI, 2=H00)	WORD		0/1/2	num
V2	V2-H42	36674	44028	RW	Configuration input Pb2 (0=Disable, 1=DI, 2=H00)	WORD		0/1/2	num
V2	V2-H43	36676	44028.2	RW	Configuration input Pb3 (0=Disable, 1=DI, 2=H00)	WORD		0/1/2	num
V2	V2-H44	36678	44028.4	RW	Configuration input Pb4 (0=Disable, 1=DI, 2=H00)	WORD		0/1/2	num
V2	V2-H45	36680	44028.6	RW	Configuration input Pb5 (0=Disable, 1=DI, 2=H00)	WORD		0/1/2	num
V2	V2-H50	36728	44029.4	RW	Configuration Type of Analogue Output	WORD		0/1	num
V2	V2-H51	36730	44029.6	RW	Regulator associated to analogue output	WORD		0/1	num
V2	V2-H68	36732	44030	RW	Clock Present	WORD		0/1	num
V2	V2-H70	36688	44030.2	RW	Select probe 1 for virtual probe	WORD		0...5	num
V2	V2-H71	36690	44030.4	RW	Select probe 2 for virtual probe	WORD		0...5	num
V2	V2-H72	36692	44030.6	RW	% calculation virtual probe day	WORD		0...100	%
V2	V2-H73	36694	44031	RW	% calculation virtual probe night	WORD		0...100	%
V2	V2-UL	---	44036	RW	Parameter transfer function visibility (Device -> Copy Card)	2 BIT		0...3	num
V2	V2-dL	---	44036.2	RW	Parameter transfer function visibility (Copy Card -> Device)	2 BIT		0...3	num
V2	V2-Fr	---	44036.4	RW	Format Copy Card function visibility	2 BIT		0...3	num
APPLICATION 3 PARAMETERS									
	V3-SP1	37630	44160.6	RW	Setpoint	WORD		V3-LS1...V3-HS1	°C/°F
	V3-SP2	37634	44161.2	RW	Thermostat 2 setpoint	WORD		V3-LS2...V3-HS2	°C/°F
V3	V3-rE	37624	44160	RW	Regulation mode	WORD		0...4	num
V3	V3-rP1	37626	44160.2	RW	Regulation probe 1	WORD		0...7	num
V3	V3-rP2	37628	44160.4	RW	Thermostat 2 regulation probe	WORD		0...7	num
V3	V3-dF1	37632	44161	RW	Differential/proportional band	WORD		-58.0...302	°C/°F
V3	V3-dF2	37636	44161.4	RW	Thermostat 2 differential	WORD		-58.0...302	°C/°F
V3	V3-Stt	37642	44161.6	RW	Differential control mode	WORD		0/1	num
V3	V3-HS1	37648	44162	RW	SP1 maximum value	WORD		V3-LS1...V3-HdL	°C/°F
V3	V3-LS1	37650	44162.2	RW	SP1 minimum value	WORD		V3-LdL...V3-HS1	°C/°F
V3	V3-HS2	37652	44162.4	RW	SP2 maximum value	WORD		V3-LS2...V3-HdL	°C/°F
V3	V3-LS2	37654	44162.6	RW	SP2 minimum value	WORD		V3-LdL...V3-HS2	°C/°F
V3	V3-HC1	37644	44163	RW	Thermostat 1 mode	WORD		0/1	num
V3	V3-HC2	37646	44163.2	RW	Thermostat 2 mode	WORD		0/1	num
V3	V3-CC	37684	44163.4	RW	Double power step control	WORD		0/1	num
V3	V3-Cit	37664	44163.6	RW	Minimum compressor ON time	WORD		0...250	min
V3	V3-CAt	37666	44164	RW	Maximum compressor ON time	WORD		0...250	min
V3	V3-OnT	37676	44164.2	RW	ON time for faulty probe	WORD		0...250	min
V3	V3-OfT	37678	44164.4	RW	OFF time for faulty probe	WORD		0...250	min
V3	V3-dOn	37668	44164.6	RW	Switch on delay	WORD		0...250	sec
V3	V3-dOF	37670	44165	RW	Delay after switching off	WORD		0...250	min
V3	V3-dbi	37672	44165.2	RW	Delay between switch-ons	WORD		0...250	min
V3	V3-odO	37674	44165.4	RW	Output delay from power-on	WORD		0...250	min
V3	V3-CP2	37680	44165.6	RW	Compressor 2 switch-on delay	WORD		0...250	sec
V3	V3-CS2	37682	44166	RW	Power step 2 switch-on delay	WORD		0...250	min
V3	V3-CFP	37842	44166.2	RW	Preventilation time	WORD		0...255	sec
V3	V3-CFd	37844	44166.4	RW	Fan mode	WORD		0/1	num
V3	V3-OF1	37686	44166.6	RW	Forced remote offset	WORD		-50.0...50.0	°C/°F
V3	V3-dP1	37688	44167	RW	Selection defrost probe 1	WORD		0...7	num





FOLDER	LABEL	PAR. ADDRESS VALUE	PAR. ADDRESS Vis.	R/W	DESCRIPTION	DATA SIZE	CPL	RANGE	UM
V3	V3-dP2	37690	44167.2	RW	Selection defrost probe 2	WORD		0..7	num
V3	V3-dtY	37696	44167.4	RW	Defrost mode	WORD		0..4	num
V3	V3-dFt	37692	44167.6	RW	Defrost activation mode with two probes	WORD		0/1/2	num
V3	V3-dit	37698	44168	RW	Interval between defrost cycles	WORD		0...250	hours
V3	V3-dt1	37704	44168.2	RW	Unit of measurement for defrost interval	WORD		0/1/2	num
V3	V3-dt2	37706	44168.4	RW	Unit of measure for defrost duration	WORD		0/1/2	num
V3	V3-dCt	37694	44168.6	RW	Defrost interval count mode	WORD		0...5	num
V3	V3-dOH	37708	44169	RW	Defrost interval count mode	WORD		0...250	min
V3	V3-dE1	37700	44169.2	RW	Evaporator 1 defrost time-out	WORD		1...250	min
V3	V3-dE2	37702	44169.4	RW	Evaporator 2 defrost time-out	WORD		1...250	min
V3	V3-dS1	37712	44169.6	RW	Probe 1 end of defrost temperature	WORD		-58.0...302	°C/°F
V3	V3-dS2	37714	44170	RW	Probe 2 end of defrost temperature	WORD		-58.0...302	°C/°F
V3	V3-dSS	37710	44170.2	RW	Start defrost temperature threshold	WORD		-58.0...302	°C/°F
V3	V3-dPO	37716	44170.4	RW	Request defrost activation from power on	WORD		0/1	num
V3	V3-tcd	37718	44170.6	RW	Min. compressor ON or OFF time before defrost	WORD		-60...60	min
V3	V3-ndE	37720	44171	RW	Minimum defrost time (for hot gas only)	WORD		0...250	min
V3	V3-PdC	37722	44171.2	RW	Hot gas extraction time at defrost end	WORD		0...250	min
V3	V3-tPd	37726	44171.4	RW	Pump down time before defrost startup	WORD		0...255	min
V3	V3-dPH	37604	44171.6	RW	Start time for periodical defrost	WORD		0...24	hours
V3	V3-dPn	37606	44172	RW	Start time minutes for periodical defrost	WORD		0...59	min
V3	V3-dPd	37608	44172.2	RW	Periodical defrost interval duration	WORD		1...7	Day
V3	V3-Fd1	37502	44172.4	RW	Weekend/public holiday 1	WORD		0...7	num
V3	V3-Fd2	37504	44172.6	RW	Weekend/public holiday 2	WORD		0...7	num
V3	V3-Edt	37506	44173	RW	Customized duration and temperature for each event	WORD		0/1	num
V3	V3-d1H	37508	44173.2	RW	Start time weekday defrost 1	WORD		0...24	hours
V3	V3-d1n	37510	44173.4	RW	Start time minutes weekday defrost 1	WORD		0...59	min
V3	V3-d1t	37512	44173.6	RW	Weekday defrost 1 duration	WORD		0...250	min
V3	V3-d1S	37514	44174	RW	End of weekday defrost 1 temperature	WORD		-58.0...302	°C/°F
V3	V3-d2H	37516	44174.2	RW	Start time weekday defrost 2	WORD		V3-d1H...24	hours
V3	V3-d2n	37518	44174.4	RW	Start time minutes weekday defrost 2	WORD		0...59	min
V3	V3-d2t	37520	44174.6	RW	Weekday defrost 2 duration	WORD		0...250	min
V3	V3-d2S	37522	44175	RW	End of weekday defrost 2 temperature	WORD		-58.0...302	°C/°F
V3	V3-d3H	37524	44175.2	RW	Start time weekday defrost 3	WORD		V3-d2H...24	hours
V3	V3-d3n	37526	44175.4	RW	Start time minutes weekday defrost 3	WORD		0...59	min
V3	V3-d3t	37528	44175.6	RW	Weekday defrost 3 duration	WORD		0...250	min
V3	V3-d3S	37530	44176	RW	End of weekday defrost 3 temperature	WORD		-58.0...302	°C/°F
V3	V3-d4H	37532	44176.2	RW	Start time weekday defrost 4	WORD		V3-d3H...24	hours
V3	V3-d4n	37534	44176.4	RW	Start time minutes weekday defrost 4	WORD		0...59	min
V3	V3-d4t	37536	44176.6	RW	Weekday defrost 4 duration	WORD		0...250	min
V3	V3-d4S	37538	44177	RW	End of weekday defrost 4 temperature	WORD		-58.0...302	°C/°F
V3	V3-d5H	37540	44177.2	RW	Start time weekday defrost 5	WORD		V3-d4H...24	hours
V3	V3-d5n	37542	44177.4	RW	Start time minutes weekday defrost 5	WORD		0...59	min
V3	V3-d5t	37544	44177.6	RW	Weekday defrost 5 duration	WORD		0...250	min
V3	V3-d5S	37546	44178	RW	End of weekday defrost 5 temperature	WORD		-58.0...302	°C/°F
V3	V3-d6H	37548	44178.2	RW	Start time weekday defrost 6	WORD		V3-d5H...24	hours
V3	V3-d6n	37550	44178.4	RW	Start time minutes weekday defrost 6	WORD		0...59	min
V3	V3-d6t	37552	44178.6	RW	Weekday defrost 6 duration	WORD		0...250	min
V3	V3-d6S	37554	44179	RW	End of weekday defrost 6 temperature	WORD		-58.0...302	°C/°F
V3	V3-F1H	37556	44179.2	RW	Start time weekend/public holiday defrost 1	WORD		0...24	hours
V3	V3-F1n	37558	44179.4	RW	Weekend/public holiday defrost 1 start time minutes	WORD		0...59	min
V3	V3-F1t	37560	44179.6	RW	Weekend/public holiday defrost 1 duration	WORD		0...250	min
V3	V3-F1S	37562	44180	RW	End of weekend/public holiday defrost 1 temperature	WORD		-58.0...302	°C/°F
V3	V3-F2H	37564	44180.2	RW	Start time weekend/public holiday defrost 2	WORD		V3-F1H...24	hours
V3	V3-F2n	37566	44180.4	RW	Weekend/public holiday defrost 2 start time minutes	WORD		0...59	min
V3	V3-F2t	37568	44180.6	RW	Weekend/public holiday defrost 2 duration	WORD		0...250	min
V3	V3-F2S	37570	44181	RW	End of weekend/public holiday defrost 1 temperature	WORD		-58.0...302	°C/°F



FOLDER	LABEL	PAR. ADDRESS VALUE	PAR. ADDRESS Vis.	R/W	DESCRIPTION	DATA SIZE	CPL	RANGE	UM
V3	V3-F3H	37572	44181.2	RW	Start time weekend/public holiday defrost 3	WORD		V3-F2H...24	hours
V3	V3-F3n	37574	44181.4	RW	Weekend/public holiday defrost 3 start time minutes	WORD		0...59	min
V3	V3-F3t	37576	44181.6	RW	Weekend/public holiday defrost 3 duration	WORD		0...250	min
V3	V3-F3S	37578	44182	RW	End of weekend/public holiday defrost 1 temperature	WORD		-58.0...302	°C/°F
V3	V3-F4H	37580	44182.2	RW	Start time weekend/public holiday defrost 4	WORD		V3-F3H...24	hours
V3	V3-F4n	37582	44182.4	RW	Weekend/public holiday defrost 4 start time minutes	WORD		0...59	min
V3	V3-F4t	37584	44182.6	RW	Weekend/public holiday defrost 4 duration	WORD		0...250	min
V3	V3-F4S	37586	44183	RW	End of weekend/public holiday defrost 1 temperature	WORD		-58.0...302	°C/°F
V3	V3-F5H	37588	44183.2	RW	Start time weekend/public holiday defrost 5	WORD		V3-F4H...24	hours
V3	V3-F5n	37590	44183.4	RW	Weekend/public holiday defrost 5 start time minutes	WORD		0...59	min
V3	V3-F5t	37592	44183.6	RW	Weekend/public holiday defrost 5 duration	WORD		0...250	min
V3	V3-F5S	37594	44184	RW	End of weekend/public holiday defrost 1 temperature	WORD		-58.0...302	°C/°F
V3	V3-F6H	37596	44184.2	RW	Start time weekend/public holiday defrost 6	WORD		V3-F5H...24	hours
V3	V3-F6n	37598	44184.4	RW	Weekend/public holiday defrost 6 start time minutes	WORD		0...59	min
V3	V3-F6t	37600	44184.6	RW	Weekend/public holiday defrost 6 duration	WORD		0...250	min
V3	V3-F6S	37602	44185	RW	End of weekend/public holiday defrost 6 temperature	WORD		-58.0...302	°C/°F
V3	V3-FP1	37728	44185.2	RW	Evaporator fan probe in normal mode	WORD		0...7	num
V3	V3-FP2	37730	44185.4	RW	Evaporator fan probe during defrost stage	WORD		0...7	num
V3	V3-FPt	37732	44185.6	RW	FSt parameter mode	WORD		0/1	num
V3	V3-FSt	37734	44186	RW	Block fan temperature	WORD		-58.0...302	°C/°F
V3	V3-FAd	37736	44186.2	RW	Fan differential	WORD		0.1...25.0	°C/°F
V3	V3-Fdt	37738	44186.4	RW	Fan activation delay after compressor start	WORD		0...250	min
V3	V3-dt	37748	44186.6	RW	Dripping time	WORD		0...250	min
V3	V3-dFd	37744	44187	RW	Evaporator fan mode during defrost	WORD		0/1	num
V3	V3-FCO	37742	44187.2	RW	Evaporator fan mode	WORD		0...3	num
V3	V3-FdC	37740	44187.6	RW	Fan switch off delay after compressor stop	WORD		0...250	min
V3	V3-FOn	37750	44188	RW	Fan ON time in Duty Cycle	WORD		0...250	min
V3	V3-FOF	37752	44188.2	RW	Fan OFF time in Duty Cycle	WORD		0...250	min
V3	V3-Fnn	37754	44188.4	RW	Duty cycle on time during night mode	WORD		0...250	min
V3	V3-FnF	37756	44188.6	RW	Duty cycle off time during night mode	WORD		0...250	min
V3	V3-rA1	37784	44189	RW	Temperature alarm probe 1 selection	WORD		0...6	num
V3	V3-rA2	37786	44189.2	RW	Temperature alarm probe 2 selection	WORD		0...6	num
V3	V3-Att	37788	44189.4	RW	Parameter HAL and LAL mode	WORD		0/1	num
V3	V3-AFd	37790	44189.6	RW	Alarm setpoint differential	WORD		0.1...25.0	°C/°F
V3	V3-HA1	37792	44190	RW	Probe 1 maximum alarm	WORD		V3-LA1...302	°C/°F
V3	V3-LA1	37794	44190.2	RW	Probe 1 minimum alarm	WORD		-58.0...V3-HA1	°C/°F
V3	V3-HA2	37796	44190.4	RW	Probe 2 maximum alarm	WORD		V3-LA2...302	°C/°F
V3	V3-LA2	37798	44190.6	RW	Probe 2 minimum alarm	WORD		-58.0...V3-HA2	°C/°F
V3	V3-PAO	37800	44191	RW	Exclude alarm at switch on	WORD		0...10	hours
V3	V3-dAO	37804	44191.2	RW	Exclude alarm after defrost	WORD		0...250	min
V3	V3-OAO	37802	44191.4	RW	Alarm signal delay after closing door	WORD		0...10	hours
V3	V3-tdO	37892	44191.6	RW	Open door disabling time	WORD		0...250	num
V3	V3-tA1	37806	44192	RW	LA1 and HA1 alarm signal delay	WORD		0...250	min
V3	V3-tA2	37808	44192.2	RW	LA2 and HA2 alarm signal delay	WORD		0...250	min
V3	V3-dAt	37724	44192.4	RW	Enable alarm at end of defrost	WORD		0/1	num
V3	V3-EAL	37812	44192.6	RW	External alarm switches off utilities	WORD		0/1/2	num
V3	V3-tP	37894	44193	RW	Enable alarm overriding from any key	WORD		0/1	num
V3	V3-Art	37782	44193.2	RW	Alarm activation period supervisor link	WORD		0...250	min*10
V3	V3-dSd	37776	44193.4	RW	Enable light relay from door switch	WORD		0/1	num
V3	V3-dLt	37778	44193.6	RW	Delay disabling light relay	WORD		0...250	min
V3	V3-OFL	37780	44194	RW	Light key always disables light relay	WORD		0/1	num
V3	V3-dOd	37810	44194.2	RW	Door switch turns off utilities	WORD		0...3	num
V3	V3-dOA	37814	44194.4	RW	Action forced by digital input	WORD		0...5	num
V3	V3-PEA	37816	44194.6	RW	DI selected to block/release resources	WORD		0...3	num
V3	V3-dCO	37818	44195	RW	Delay to activate/switch off compressor evap. fan	WORD		0...250	min
V3	V3-dFO	37820	44195.2	RW	Delay to activate/switch off evap. fan	WORD		0...250	min



FOLDER	LABEL	PAR. ADDRESS VALUE	PAR. ADDRESS Vis.	R/W	DESCRIPTION	DATA SIZE	CPL	RANGE	UM
V3	V3-ASb	37872	44195.4	RW	Key/AUX input/Light active when OFF	WORD		0/1	num
V3	V3-L00	37376	44195.6	RW	Shared probe	WORD		0...6	num
V3	V3-L01	37378	44196	RW	Display value shared	WORD		0/1/2	num
V3	V3-L02	37380	44196.2	RW	Send setpoint value when modified	WORD		0/1	num
V3	V3-L03	37382	44196.4	RW	Send defrost request	WORD		0/1	num
V3	V3-L04	37384	44196.6	RW	End defrost mode	WORD		0/1	num
V3	V3-L05	37386	44197	RW	Synchronization of Stand-By command	WORD		0/1	num
V3	V3-L06	37388	44197.2	RW	Synchronization of light command	WORD		0/1	num
V3	V3-L07	37390	44197.4	RW	Synchronization of reduced setpoint command	WORD		0/1	num
V3	V3-L08	37392	44197.6	RW	Synchronization of AUX command	WORD		0/1	num
V3	V3-L10	37896	44198.2	RW	Wait for end of dependent defrost timeout	WORD		0...250	min
V3	V3-PEn	37772	44198.4	RW	Number of errors allowed	WORD		0...15	num
V3	V3-PEi	37774	44198.6	RW	Error count interval	WORD		1...250	min
V3	V3-dcS	37764	44199	RW	Deep Cooling Setpoint	WORD		-58.0...302	°C/°F
V3	V3-tdc	37766	44199.2	RW	Deep Cooling duration	WORD		0...250	min
V3	V3-dcc	37768	44199.4	RW	Waiting time to start defrost cycle	WORD		0...250	min
V3	V3-ESt	37622	44199.6	RW	Type of Energy Saving	WORD		0...4	num
V3	V3-ESF	37758	44200	RW	Night mode enabled	WORD		0/1	num
V3	V3-Cdt	37760	44200.2	RW	Min. door closed time to activate reduced setpoint	WORD		0...255	min*10
V3	V3-ESo	37762	44200.4	RW	Cumulative door open time	WORD		0...10	num
V3	V3-OS1	37656	44200.6	RW	Offset SP1	WORD		-50.0...50.0	°C/°F
V3	V3-OS2	37658	44201	RW	Offset SP2	WORD		-50.0...50.0	°C/°F
V3	V3-Od1	37660	44201.2	RW	Door energy saving offset 1	WORD		-50.0...50.0	°C/°F
V3	V3-Od2	37662	44201.4	RW	Door energy saving offset 2	WORD		-50.0...50.0	°C/°F
V3	V3-dn1	37638	44201.6	RW	dn1 Differential in energy saving mode 1	WORD		-58.0...302	°C/°F
V3	V3-dn2	37640	44202	RW	dn2 Differential in energy saving mode 2	WORD		-58.0...302	°C/°F
V3	V3-EdH	37610	44202.2	RW	Start time weekday Energy Saving	WORD		0...24	hours
V3	V3-Edn	37612	44202.4	RW	Weekday Energy Saving start time minutes	WORD		0...59	min
V3	V3-Edd	37614	44202.6	RW	Weekday Energy Saving event duration	WORD		1...72	hours
V3	V3-EFH	37616	44203	RW	Weekend/public holiday Energy Saving start time	WORD		0...24	hours
V3	V3-EFn	37618	44203.2	RW	Weekend/public holiday Energy Saving start time minutes	WORD		0...59	min
V3	V3-EFd	37620	44203.4	RW	Weekend/public holiday Energy Saving event duration	WORD		1...72	hours
V3	V3-FH	37822	44203.6	RW	Regulation mode	WORD		0...7	num
V3	V3-FHt	37826	44204	RW	Frame heater period	WORD		1...2500	sec*10
V3	V3-FH0	37828	44204.2	RW	Frame heater setpoint	WORD		-58.0...302	°C/°F
V3	V3-FH1	37830	44204.4	RW	Frame heater offset	WORD		0.0...25.0	°C/°F
V3	V3-FH2	37832	44204.6	RW	Frame heater band	WORD		0.0...25.0	°C/°F
V3	V3-FH3	37834	44205	RW	Min. percentage	WORD		0...100	%
V3	V3-FH4	37836	44205.2	RW	Maximum percentage/Duty Cycle Day	WORD		0...100	%
V3	V3-FH5	37838	44205.4	RW	Maximum percentage/Duty Cycle Night (ES)	WORD		0...100	%
V3	V3-FH6	37840	44205.6	RW	Percentage during defrost	WORD		0...100	%
V3	V3-LOC	37846	44206	RW	Keypad lock	WORD		0/1	num
V3	V3-PS1	37848	44206.2	RW	Password 1	WORD		0...250	num
V3	V3-PS2	37850	44206.4	RW	Password 2	WORD		0...250	num
V3	V3-ndt	37852	44206.6	RW	Display with decimal point	WORD		0/1	num
V3	V3-CA1	37464	44207	RW	Calibration Pb1	WORD		-30.0...30.0	°C/°F
V3	V3-CA2	37466	44207.2	RW	Calibration Pb2	WORD		-30.0...30.0	°C/°F
V3	V3-CA3	37468	44207.4	RW	Calibration Pb3	WORD		-30.0...30.0	°C/°F
V3	V3-CA4	37470	44207.6	RW	Calibration Pb4	WORD		-30.0...30.0	°C/°F
V3	V3-CA5	37472	44208	RW	Calibration Pb5	WORD		-30.0...30.0	°C/°F
V3	V3-LdL	37854	44208.6	RW	Minimum value displayable	WORD		-58.0...V3-HdL	°C/°F
V3	V3-HdL	37856	44209	RW	Maximum value displayable	WORD		V3-LdL...302	°C/°F
V3	V3-ddL	37858	44209.2	RW	Block display during defrost	WORD		0/1/2	num
V3	V3-Ldd	37860	44209.4	RW	"ddL" Release Time-Out	WORD		0...250	min
V3	V3-dro	37862	44209.6	RW	°C/°F selection (0=°C, 1=°F)	WORD		0/1	num
V3	V3-ddd	37866	44210.2	RW	Main Display	WORD		0...7	num



FOLDER	LABEL	PAR. ADDRESS VALUE	PAR. ADDRESS Vis.	R/W	DESCRIPTION	DATA SIZE	CPL	RANGE	UM
V3	V3-ddE	37868	44210.4	RW	Main display on ECHO	WORD		0..7	num
V3	V3-rPH	37770	44210.6	RW	Select HACCP alarm probe	WORD		0..5	num
V3	V3-H00	37396	44211	RW	Type of probe Pb1-Pb2-Pb3-Pb4-Pb5 (0=NTC, 1=PTC, 2=PT1000)	WORD		0/1/2	num
V3	V3-H02	37870	44211.2	RW	Key activation time	WORD		0...250	sec
V3	V3-H08	37874	44211.4	RW	Stand-By mode	WORD		0/1/2	num
V3	V3-H11	37406	44211.6	RW	Configuration input DI1	WORD		-17...17	num
V3	V3-H12	37408	44212	RW	Configuration input DI2	WORD		-17...17	num
V3	V3-H13	37410	44212.2	RW	Configuration input DI3	WORD		-17...17	num
V3	V3-H14	37412	44212.4	RW	Configuration input DI4	WORD		-17...17	num
V3	V3-H15	37414	44212.6	RW	Configuration input DI5	WORD		-17...17	num
V3	V3-H16	37416	44213	RW	Configuration input DI6	WORD		-17...17	num
V3	V3-H17	37418	44213.2	RW	Configuration input DI7	WORD		-17...17	num
V3	V3-H18	37420	44213.4	RW	Configuration input DI8	WORD		-17...17	num
V3	V3-dti	37438	44213.6	RW	Unit of measure for digital inputs 1 and 2	WORD		0/1	num
V3	V3-d11	37422	44214	RW	Activation delay for digital input 1	WORD		0...255	min/sec
V3	V3-d12	37424	44214.2	RW	Activation delay for digital input 2	WORD		0...255	min/sec
V3	V3-d13	37426	44214.4	RW	Activation delay for digital input 3	WORD		0...255	min
V3	V3-d14	37428	44214.6	RW	Activation delay for digital input 4	WORD		0...255	min
V3	V3-d15	37430	44215	RW	Activation delay for digital input 5	WORD		0...255	min
V3	V3-d16	37432	44215.2	RW	Activation delay for digital input 6	WORD		0...255	min
V3	V3-d17	37434	44215.4	RW	Activation delay for digital input 7	WORD		0...255	min
V3	V3-d18	37436	44215.6	RW	Activation delay for digital input 8	WORD		0...255	min
V3	V3-H21	37480	44216	RW	Configuration Relay 1	WORD		0...13	num
V3	V3-H22	37482	44216.2	RW	Configuration Relay 2	WORD		0...13	num
V3	V3-H23	37484	44216.4	RW	Configuration Relay 3	WORD		0...13	num
V3	V3-H24	37486	44216.6	RW	Configuration Relay 4	WORD		0...13	num
V3	V3-H25	37488	44217	RW	Configuration Relay 5	WORD		0...13	num
V3	V3-H26	37490	44217.2	RW	Configuration Relay 6	WORD		0...13	num
V3	V3-H27	37492	44217.4	RW	Configuration Relay 7	WORD		0...13	num
V3	V3-H29	37494	44217.6	RW	Enable buzzer	WORD		0/1	num
V3	V3-H31	37876	44218	RW	Configuration of UP key	WORD		0...8	num
V3	V3-H32	37878	44218.2	RW	Configuration of DOWN key	WORD		0...8	num
V3	V3-H33	37880	44218.4	RW	ESC key configuration	WORD		0...8	num
V3	V3-H41	37440	44219.6	RW	Configuration input Pb1 (0=Disable, 1=DI, 2=H00)	WORD		0/1/2	num
V3	V3-H42	37442	44220	RW	Configuration input Pb2 (0=Disable, 1=DI, 2=H00)	WORD		0/1/2	num
V3	V3-H43	37444	44220.2	RW	Configuration input Pb3 (0=Disable, 1=DI, 2=H00)	WORD		0/1/2	num
V3	V3-H44	37446	44220.4	RW	Configuration input Pb4 (0=Disable, 1=DI, 2=H00)	WORD		0/1/2	num
V3	V3-H45	37448	44220.6	RW	Configuration input Pb5 (0=Disable, 1=DI, 2=H00)	WORD		0/1/2	num
V3	V3-H50	37496	44221.4	RW	Configuration Type of Analogue Output	WORD		0/1	num
V3	V3-H51	37498	44221.6	RW	Regulator associated to analogue output	WORD		0/1	num
V3	V3-H68	37500	44222	RW	Clock Present	WORD		0/1	num
V3	V3-H70	37456	44222.2	RW	Select probe 1 for virtual probe	WORD		0..5	num
V3	V3-H71	37458	44222.4	RW	Select probe 2 for virtual probe	WORD		0..5	num
V3	V3-H72	37460	44222.6	RW	% calculation virtual probe day	WORD		0...100	%
V3	V3-H73	37462	44223	RW	% calculation virtual probe night	WORD		0...100	%
V3	V3-UL	---	44228	RW	Parameter transfer function visibility (Device -> Copy Card)	2 BIT		0...3	num
V3	V3-dL	---	44228.2	RW	Parameter transfer function visibility (Copy Card -> Device)	2 BIT		0...3	num
V3	V3-Fr	---	44228.4	RW	Format Copy Card function visibility	2 BIT		0...3	num
<b>APPLICATION 4 PARAMETERS</b>									
	V4-SP1	38398	44352.6	RW	Setpoint	WORD		V4-LS1...V4-HS1	°C/°F
	V4-SP2	38402	44353.2	RW	Thermostat 2 setpoint	WORD		V4-LS2...V4-HS2	°C/°F
V4	V4-rE	38392	44352	RW	Regulation mode	WORD		0..4	num
V4	V4-rP1	38394	44352.2	RW	Regulation probe 1	WORD		0..7	num
V4	V4-rP2	38396	44352.4	RW	Thermostat 2 regulation probe	WORD		0..7	num
V4	V4-dF1	38400	44353	RW	Differential/proportional band	WORD		-58.0...302	°C/°F
V4	V4-dF2	38404	44353.4	RW	Thermostat 2 differential	WORD		-58.0...302	°C/°F



FOLDER	LABEL	PAR. ADDRESS VALUE	PAR. ADDRESS Vis.	R/W	DESCRIPTION	DATA SIZE	CPL	RANGE	UM
V4	V4-Stt	38410	44353.6	RW	Differential control mode	WORD		0/1	num
V4	V4-HS1	38416	44354	RW	SP1 maximum value	WORD		V4-LS1...V4-HdL	°C/°F
V4	V4-LS1	38418	44354.2	RW	SP1 minimum value	WORD		V4-LdL...V4-HS1	°C/°F
V4	V4-HS2	38420	44354.4	RW	SP2 maximum value	WORD		V4-LS2...V4-HdL	°C/°F
V4	V4-LS2	38422	44354.6	RW	SP2 minimum value	WORD		V4-LdL...V4-HS2	°C/°F
V4	V4-HC1	38412	44355	RW	Thermostat 1 mode	WORD		0/1	num
V4	V4-HC2	38414	44355.2	RW	Thermostat 2 mode	WORD		0/1	num
V4	V4-CC	38452	44355.4	RW	Double power step control	WORD		0/1	num
V4	V4-Cit	38432	44356.2	RW	Minimum compressor ON time	WORD		0...250	min
V4	V4-CAt	38434	44356.4	RW	Maximum compressor ON time	WORD		0...250	min
V4	V4-Ont	38444	44355.6	RW	ON time for faulty probe	WORD		0...250	min
V4	V4-OFt	38446	44356	RW	OFF time for faulty probe	WORD		0...250	min
V4	V4-dOn	38436	44356.6	RW	Switch on delay	WORD		0...250	sec
V4	V4-dOF	38438	44357	RW	Delay after switching off	WORD		0...250	min
V4	V4-dbi	38440	44357.2	RW	Delay between switch-ons	WORD		0...250	min
V4	V4-OdO	38442	44357.4	RW	Output delay from power-on	WORD		0...250	min
V4	V4-CP2	38448	44357.6	RW	Compressor 2 switch-on delay	WORD		0...250	sec
V4	V4-CS2	38450	44358	RW	Power step 2 switch-on delay	WORD		0...250	min
V4	V4-CFP	38610	44358.2	RW	Preventilation time	WORD		0...255	sec
V4	V4-CFd	38612	44358.4	RW	Fan mode	WORD		0/1	num
V4	V4-OF1	38454	44358.6	RW	Forced remote offset	WORD		-50.0...50.0	°C/°F
V4	V4-dP1	38456	44359	RW	Selection defrost probe 1	WORD		0...7	num
V4	V4-dP2	38458	44359.2	RW	Selection defrost probe 2	WORD		0...7	num
V4	V4-dtY	38464	44359.4	RW	Defrost mode	WORD		0...4	num
V4	V4-dFt	38460	44359.6	RW	Defrost activation mode with two probes	WORD		0...2	num
V4	V4-dit	38466	44361	RW	Interval between defrost cycles	WORD		0...250	hours
V4	V4-dt1	38472	44360	RW	Unit of measurement for defrost interval	WORD		0/1/2	num
V4	V4-dt2	38474	44360.2	RW	Unit of measure for defrost duration	WORD		0/1/2	num
V4	V4-dCt	38462	44360.4	RW	Defrost interval count mode	WORD		0...5	num
V4	V4-dOH	38476	44360.6	RW	Defrost interval count mode	WORD		0...250	min
V4	V4-dE1	38468	44361.2	RW	Evaporator 1 defrost time-out	WORD		1...250	min
V4	V4-dE2	38470	44361.4	RW	Evaporator 2 defrost time-out	WORD		1...250	min
V4	V4-dS1	38480	44361.6	RW	Probe 1 end of defrost temperature	WORD		-58.0...302	°C/°F
V4	V4-dS2	38482	44362	RW	Probe 2 end of defrost temperature	WORD		-58.0...302	°C/°F
V4	V4-dSS	38478	44362.2	RW	Start defrost temperature threshold	WORD		-58.0...302	°C/°F
V4	V4-dPO	38484	44362.4	RW	Request defrost activation from power on	WORD		0/1	num
V4	V4-tcd	38486	44362.6	RW	Min. compressor ON or OFF time before defrost	WORD		-60...60	min
V4	V4-ndE	38488	44363	RW	Minimum defrost time (for hot gas only)	WORD		0...250	min
V4	V4-PdC	38490	44363.2	RW	Hot gas extraction time at defrost end	WORD		0...250	min
V4	V4-tPd	38494	44363.4	RW	Pump down time before defrost startup	WORD		0...255	min
V4	V4-dPH	38372	44363.6	RW	Start time for periodical defrost	WORD		0...24	hours
V4	V4-dPn	38374	44364	RW	Start time minutes for periodical defrost	WORD		0...59	min
V4	V4-dPd	38376	44364.2	RW	Periodical defrost interval duration	WORD		1...7	Day
V4	V4-Fd1	38270	44364.4	RW	Weekend/public holiday 1	WORD		0...7	num
V4	V4-Fd2	38272	44364.6	RW	Weekend/public holiday 2	WORD		0...7	num
V4	V4-Edt	38274	44365	RW	Customized duration and temperature for each event	WORD		0/1	num
V4	V4-d1H	38276	44365.2	RW	Start time weekday defrost 1	WORD		0...24	hours
V4	V4-d1n	38278	44365.4	RW	Start time minutes weekday defrost 1	WORD		0...59	min
V4	V4-d1t	38280	44365.6	RW	Weekday defrost 1 duration	WORD		0...250	min
V4	V4-d1S	38282	44366	RW	End of weekday defrost 1 temperature	WORD		-58.0...302	°C/°F
V4	V4-d2H	38284	44366.2	RW	Start time weekday defrost 2	WORD		V4-d1H...24	hours
V4	V4-d2n	38286	44366.4	RW	Start time minutes weekday defrost 2	WORD		0...59	min
V4	V4-d2t	38288	44366.6	RW	Weekday defrost 2 duration	WORD		0...250	min
V4	V4-d2S	38290	44367	RW	End of weekday defrost 2 temperature	WORD		-58.0...302	°C/°F
V4	V4-d3H	38292	44367.2	RW	Start time weekday defrost 3	WORD		V4-d2H...24	hours
V4	V4-d3n	38294	44367.4	RW	Start time minutes weekday defrost 3	WORD		0...59	min



FOLDER	LABEL	PAR. ADDRESS VALUE	PAR. ADDRESS Vis.	R/W	DESCRIPTION	DATA SIZE	CPL	RANGE	UM
V4	V4-d3t	38296	44367.6	RW	Weekday defrost 3 duration	WORD		0...250	min
V4	V4-d3S	38298	44368	RW	End of weekday defrost 3 temperature	WORD		-58.0...302	°C/°F
V4	V4-d4H	38300	44368.2	RW	Start time weekday defrost 4	WORD		V4-d3H...24	hours
V4	V4-d4n	38302	44368.4	RW	Start time minutes weekday defrost 4	WORD		0...59	min
V4	V4-d4t	38304	44368.6	RW	Weekday defrost 4 duration	WORD		0...250	min
V4	V4-d4S	38306	44369	RW	End of weekday defrost 4 temperature	WORD		-58.0...302	°C/°F
V4	V4-d5H	38308	44369.2	RW	Start time weekday defrost 5	WORD		V4-d4H...24	hours
V4	V4-d5n	38310	44369.4	RW	Start time minutes weekday defrost 5	WORD		0...59	min
V4	V4-d5t	38312	44369.6	RW	Weekday defrost 5 duration	WORD		0...250	min
V4	V4-d5S	38314	44370	RW	End of weekday defrost 5 temperature	WORD		-58.0...302	°C/°F
V4	V4-d6H	38316	44370.2	RW	Start time weekday defrost 6	WORD		V4-d5H...24	hours
V4	V4-d6n	38318	44370.4	RW	Start time minutes weekday defrost 6	WORD		0...59	min
V4	V4-d6t	38320	44370.6	RW	Weekday defrost 6 duration	WORD		0...250	min
V4	V4-d6S	38322	44371	RW	End of weekday defrost 6 temperature	WORD		-58.0...302	°C/°F
V4	V4-F1H	38324	44371.2	RW	Start time weekend/public holiday defrost 1	WORD		0...24	hours
V4	V4-F1n	38326	44371.4	RW	Weekend/public holiday defrost 1 start time minutes	WORD		0...59	min
V4	V4-F1t	38328	44371.6	RW	Weekend/public holiday defrost 1 duration	WORD		0...250	min
V4	V4-F1S	38330	44372	RW	End of weekend/public holiday defrost 1 temperature	WORD		-58.0...302	°C/°F
V4	V4-F2H	38332	44372.2	RW	Start time weekend/public holiday defrost 2	WORD		V4-F1H...24	hours
V4	V4-F2n	38334	44372.4	RW	Weekend/public holiday defrost 2 start time minutes	WORD		0...59	min
V4	V4-F2t	38336	44372.6	RW	Weekend/public holiday defrost 2 duration	WORD		0...250	min
V4	V4-F2S	38338	44373	RW	End of weekend/public holiday defrost 1 temperature	WORD		-58.0...302	°C/°F
V4	V4-F3H	38340	44373.2	RW	Start time weekend/public holiday defrost 3	WORD		V4-F2H...24	hours
V4	V4-F3n	38342	44373.4	RW	Weekend/public holiday defrost 3 start time minutes	WORD		0...59	min
V4	V4-F3t	38344	44373.6	RW	Weekend/public holiday defrost 3 duration	WORD		0...250	min
V4	V4-F3S	38346	44374	RW	End of weekend/public holiday defrost 1 temperature	WORD		-58.0...302	°C/°F
V4	V4-F4H	38348	44374.2	RW	Start time weekend/public holiday defrost 4	WORD		V4-F3H...24	hours
V4	V4-F4n	38350	44374.4	RW	Weekend/public holiday defrost 4 start time minutes	WORD		0...59	min
V4	V4-F4t	38352	44374.6	RW	Weekend/public holiday defrost 4 duration	WORD		0...250	min
V4	V4-F4S	38354	44375	RW	End of weekend/public holiday defrost 1 temperature	WORD		-58.0...302	°C/°F
V4	V4-F5H	38356	44375.2	RW	Start time weekend/public holiday defrost 5	WORD		V4-F4H...24	hours
V4	V4-F5n	38358	44375.4	RW	Weekend/public holiday defrost 5 start time minutes	WORD		0...59	min
V4	V4-F5t	38360	44375.6	RW	Weekend/public holiday defrost 5 duration	WORD		0...250	min
V4	V4-F5S	38362	44376	RW	End of weekend/public holiday defrost 1 temperature	WORD		-58.0...302	°C/°F
V4	V4-F6H	38364	44376.2	RW	Start time weekend/public holiday defrost 6	WORD		V4-F5H...24	hours
V4	V4-F6n	38366	44376.4	RW	Weekend/public holiday defrost 6 start time minutes	WORD		0...59	min
V4	V4-F6t	38368	44376.6	RW	Weekend/public holiday defrost 6 duration	WORD		0...250	min
V4	V4-F6S	38370	44377	RW	End of weekend/public holiday defrost 6 temperature	WORD		-58.0...302	°C/°F
V4	V4-FP1	38496	44377.2	RW	Evaporator fan probe in normal mode	WORD		0...7	num
V4	V4-FP2	38498	44377.4	RW	Evaporator fan probe during defrost stage	WORD		0...7	num
V4	V4-FPt	38500	44377.6	RW	FSt parameter mode	WORD		0/1	num
V4	V4-FSt	38502	44378	RW	Block fan temperature	WORD		-58.0...302	°C/°F
V4	V4-FAd	38504	44378.2	RW	Fan differential	WORD		0.1...25.0	°C/°F
V4	V4-Fdt	38506	44378.4	RW	Fan activation delay after compressor start	WORD		0...250	min
V4	V4-dt	38516	44378.6	RW	Dripping time	WORD		0...250	min
V4	V4-dFd	38512	44379	RW	Evaporator fan mode during defrost	WORD		0/1	num
V4	V4-FCO	38510	44379.2	RW	Evaporator fan mode	WORD		0...3	num
V4	V4-FdC	38508	44379.6	RW	Fan switch off delay after compressor stop	WORD		0...250	min
V4	V4-FOn	38518	44380	RW	Fan ON time in Duty Cycle	WORD		0...250	min
V4	V4-FOF	38520	44380.2	RW	Fan OFF time in Duty Cycle	WORD		0...250	min
V4	V4-Fnn	38522	44380.4	RW	Duty cycle on time during night mode	WORD		0...250	min
V4	V4-FnF	38524	44380.6	RW	Duty cycle off time during night mode	WORD		0...250	min
V4	V4-rA1	38552	44381	RW	Temperature alarm probe 1 selection	WORD		0...6	num
V4	V4-rA2	38554	44381.2	RW	Temperature alarm probe 2 selection	WORD		0...6	num
V4	V4-Att	38556	44381.4	RW	Parameter HAL and LAL mode	WORD		0/1	num
V4	V4-AfD	38558	44381.6	RW	Alarm setpoint differential	WORD		0.1...25.0	°C/°F



FOLDER	LABEL	PAR. ADDRESS VALUE	PAR. ADDRESS Vis.	R/W	DESCRIPTION	DATA SIZE	CPL	RANGE	UM
V4	V4-HA1	38560	44382	RW	Probe 1 maximum alarm	WORD		V4-LA1...302	°C/°F
V4	V4-LA1	38562	44382.2	RW	Probe 1 minimum alarm	WORD		-58.0...V4-HA1	°C/°F
V4	V4-HA2	38564	44382.4	RW	Probe 2 maximum alarm	WORD		V4-LA2...302	°C/°F
V4	V4-LA2	38566	44382.6	RW	Probe 2 minimum alarm	WORD		-58.0...V4-HA2	°C/°F
V4	V4-PAO	38568	44383	RW	Exclude alarm at switch on	WORD		0...10	hours
V4	V4-dAO	38572	44383.2	RW	Exclude alarm after defrost	WORD		0...250	min
V4	V4-OAO	38570	44383.4	RW	Alarm signal delay after closing door	WORD		0...10	hours
V4	V4-tdO	38660	44383.6	RW	Open door disabling time	WORD		0...250	num
V4	V4-tA1	38574	44384	RW	LA1 and HA1 alarm signal delay	WORD		0...250	min
V4	V4-tA2	38576	44384.2	RW	LA2 and HA2 alarm signal delay	WORD		0...250	min
V4	V4-dAt	38492	44384.4	RW	Enable alarm at end of defrost	WORD		0/1	num
V4	V4-EAL	38580	44384.6	RW	External alarm switches off utilities	WORD		0/1/2	num
V4	V4-tP	38662	44385	RW	Enable alarm overriding from any key	WORD		0/1	num
V4	V4-Art	38550	44385.2	RW	Alarm activation period supervisor link	WORD		0...250	min*10
V4	V4-dSd	38544	44385.4	RW	Enable light relay from door switch	WORD		0/1	num
V4	V4-dLt	38546	44385.6	RW	Delay disabling light relay	WORD		0...250	min
V4	V4-OFL	38548	44386	RW	Light key always disables light relay	WORD		0/1	num
V4	V4-dOd	38578	44386.2	RW	Door switch turns off utilities	WORD		0...3	num
V4	V4-dOA	38582	44386.4	RW	Action forced by digital input	WORD		0...5	num
V4	V4-PEA	38584	44386.6	RW	DI selected to block/release resources	WORD		0...3	num
V4	V4-dCO	38586	44387	RW	Delay to activate/switch off compressor evap. fan	WORD		0...250	min
V4	V4-dFO	38588	44387.2	RW	Delay to activate/switch off evap. fan	WORD		0...250	min
V4	V4-ASb	38640	44387.4	RW	Key/AUX input/Light active when OFF	WORD		0/1	num
V4	V4-L00	38144	44387.6	RW	Shared probe	WORD		0...6	num
V4	V4-L01	38146	44388	RW	Display value shared	WORD		0/1/2	num
V4	V4-L02	38148	44388.2	RW	Send setpoint value when modified	WORD		0/1	num
V4	V4-L03	38150	44388.4	RW	Send defrost request	WORD		0/1	num
V4	V4-L04	38152	44388.6	RW	End defrost mode	WORD		0/1	num
V4	V4-L05	38154	44389	RW	Synchronization of Stand-By command	WORD		0/1	num
V4	V4-L06	38156	44389.2	RW	Synchronization of light command	WORD		0/1	num
V4	V4-L07	38158	44389.4	RW	Synchronization of reduced setpoint command	WORD		0/1	num
V4	V4-L08	38160	44389.6	RW	Synchronization of AUX command	WORD		0/1	num
V4	V4-L10	38664	44390.2	RW	Wait for end of dependent defrost timeout	WORD		0...250	min
V4	V4-PEn	38540	44390.4	RW	Number of errors allowed	WORD		0...15	num
V4	V4-PEi	38542	44390.6	RW	Error count interval	WORD		1...250	min
V4	V4-dcS	38532	44391	RW	Deep Cooling Setpoint	WORD		-58.0...302	°C/°F
V4	V4-tdc	38534	44391.2	RW	Deep Cooling duration	WORD		0...250	min
V4	V4-dcc	38536	44391.4	RW	Waiting time to start defrost cycle	WORD		0...250	min
V4	V4-ESt	38390	44391.6	RW	Type of Energy Saving	WORD		0...4	num
V4	V4-ESF	38526	44392	RW	Night mode enabled	WORD		0/1	num
V4	V4-Cdt	38528	44392.2	RW	Min. door closed time to activate reduced setpoint	WORD		0...255	min*10
V4	V4-ESo	38530	44392.4	RW	Cumulative door open time	WORD		0...10	num
V4	V4-OS1	38424	44392.6	RW	Offset SP1	WORD		-50.0...50.0	°C/°F
V4	V4-OS2	38426	44393	RW	Offset SP2	WORD		-50.0...50.0	°C/°F
V4	V4-Od1	38428	44393.2	RW	Door energy saving offset 1	WORD		-50.0...50.0	°C/°F
V4	V4-Od2	38430	44393.4	RW	Door energy saving offset 2	WORD		-50.0...50.0	°C/°F
V4	V4-dn1	38406	44393.6	RW	dn1 Differential in energy saving mode 1	WORD		-58.0...302	°C/°F
V4	V4-dn2	38408	44394	RW	dn2 Differential in energy saving mode 2	WORD		-58.0...302	°C/°F
V4	V4-EdH	38378	44394.2	RW	Start time weekday Energy Saving	WORD		0...24	hours
V4	V4-Edn	38380	44394.4	RW	Weekday Energy Saving start time minutes	WORD		0...59	min
V4	V4-Edd	38382	44394.6	RW	Weekday Energy Saving event duration	WORD		1...72	hours
V4	V4-EFH	38384	44395	RW	Weekend/public holiday Energy Saving start time	WORD		0...24	hours
V4	V4-EFn	38386	44395.2	RW	Weekend/public holiday Energy Saving start time minutes	WORD		0...59	min
V4	V4-EFd	38388	44395.4	RW	Weekend/public holiday Energy Saving event duration	WORD		1...72	hours
V4	V4-FH	38590	44395.6	RW	Regulation mode	WORD		0...7	num
V4	V4-FHt	38594	44396	RW	Frame heater period	WORD		1...2500	sec*10



FOLDER	LABEL	PAR. ADDRESS VALUE	PAR. ADDRESS Vis.	R/W	DESCRIPTION	DATA SIZE	CPL	RANGE	UM
V4	V4-FH0	38596	44396.2	RW	Frame heater setpoint	WORD		-58.0...302	°C/°F
V4	V4-FH1	38598	44396.4	RW	Frame heater offset	WORD		0.0...25.0	°C/°F
V4	V4-FH2	38600	44396.6	RW	Frame heater band	WORD		0.0...25.0	°C/°F
V4	V4-FH3	38602	44397	RW	Min. percentage	WORD		0...100	%
V4	V4-FH4	38604	44397.2	RW	Maximum percentage/Duty Cycle Day	WORD		0...100	%
V4	V4-FH5	38606	44397.4	RW	Maximum percentage/Duty Cycle Night (ES)	WORD		0...100	%
V4	V4-FH6	38608	44397.6	RW	Percentage during defrost	WORD		0...100	%
V4	V4-LOC	38614	44398	RW	Keypad lock	WORD		0/1	num
V4	V4-PS1	38616	44398.2	RW	Password 1	WORD		0...250	num
V4	V4-PS2	38618	44398.4	RW	Password 2	WORD		0...250	num
V4	V4-ndt	38620	44398.6	RW	Display with decimal point	WORD		0/1	num
V4	V4-CA1	38232	44399	RW	Calibration Pb1	WORD		-30.0...30.0	°C/°F
V4	V4-CA2	38234	44399.2	RW	Calibration Pb2	WORD		-30.0...30.0	°C/°F
V4	V4-CA3	38236	44399.4	RW	Calibration Pb3	WORD		-30.0...30.0	°C/°F
V4	V4-CA4	38238	44399.6	RW	Calibration Pb4	WORD		-30.0...30.0	°C/°F
V4	V4-CA5	38240	44400	RW	Calibration Pb5	WORD		-30.0...30.0	°C/°F
V4	V4-LdL	38622	44400.6	RW	Minimum value displayable	WORD		-58.0...V4-HdL	°C/°F
V4	V4-HdL	38624	44401	RW	Maximum value displayable	WORD		V4-LdL...302	°C/°F
V4	V4-ddL	38626	44401.2	RW	Block display during defrost	WORD		0...2	num
V4	V4-Ldd	38628	44401.4	RW	"ddL" Release Time-Out	WORD		0...250	min
V4	V4-dro	38630	44401.6	RW	°C/°F selection (0=°C, 1=°F)	WORD		0...1	num
V4	V4-ddd	38634	44402.2	RW	Main Display	WORD		0...7	num
V4	V4-ddE	38636	44402.4	RW	Main display on ECHO	WORD		0...7	num
V4	V4-rPH	38538	44402.6	RW	Select HACCP alarm probe	WORD		0...5	num
V4	V4-H00	38164	44403	RW	Type of probe Pb1-Pb2-Pb3-Pb4-Pb5 (0=NTC, 1=PTC, 2=PT1000)	WORD		0...2	num
V4	V4-H02	38638	44403.2	RW	Key activation time	WORD		0...250	sec
V4	V4-H08	38642	44403.4	RW	Stand-By mode	WORD		0...2	num
V4	V4-H11	38174	44403.6	RW	Configuration input DI1	WORD		-17...17	num
V4	V4-H12	38176	44404	RW	Configuration input DI2	WORD		-17...17	num
V4	V4-H13	38178	44404.2	RW	Configuration input DI3	WORD		-17...17	num
V4	V4-H14	38180	44404.4	RW	Configuration input DI4	WORD		-17...17	num
V4	V4-H15	38182	44404.6	RW	Configuration input DI5	WORD		-17...17	num
V4	V4-H16	38184	44405	RW	Configuration input DI6	WORD		-17...17	num
V4	V4-H17	38186	44405.2	RW	Configuration input DI7	WORD		-17...17	num
V4	V4-H18	38188	44405.4	RW	Configuration input DI8	WORD		-17...17	num
V4	V4-dti	38206	44405.6	RW	Unit of measure for digital inputs 1 and 2	WORD		0/1	num
V4	V4-d11	38190	44406	RW	Activation delay for digital input 1	WORD		0...255	min/sec
V4	V4-d12	38192	44406.2	RW	Activation delay for digital input 2	WORD		0...255	min/sec
V4	V4-d13	38194	44406.4	RW	Activation delay for digital input 3	WORD		0...255	min
V4	V4-d14	38196	44406.6	RW	Activation delay for digital input 4	WORD		0...255	min
V4	V4-d15	38198	44407	RW	Activation delay for digital input 5	WORD		0...255	min
V4	V4-d16	38200	44407.2	RW	Activation delay for digital input 6	WORD		0...255	min
V4	V4-d17	38202	44407.4	RW	Activation delay for digital input 7	WORD		0...255	min
V4	V4-d18	38204	44407.6	RW	Activation delay for digital input 8	WORD		0...255	min
V4	V4-H21	38248	44408	RW	Configuration Relay 1	WORD		0...13	num
V4	V4-H22	38250	44408.2	RW	Configuration Relay 2	WORD		0...13	num
V4	V4-H23	38252	44408.4	RW	Configuration Relay 3	WORD		0...13	num
V4	V4-H24	38254	44408.6	RW	Configuration Relay 4	WORD		0...13	num
V4	V4-H25	38256	44409	RW	Configuration Relay 5	WORD		0...13	num
V4	V4-H26	38258	44409.2	RW	Configuration Relay 6	WORD		0...13	num
V4	V4-H27	38260	44409.4	RW	Configuration Relay 7	WORD		0...13	num
V4	V4-H29	38262	44409.6	RW	Enable buzzer	WORD		0/1	num
V4	V4-H31	38644	44410	RW	Configuration of UP key	WORD		0...8	num
V4	V4-H32	38646	44410.2	RW	Configuration of DOWN key	WORD		0...8	num
V4	V4-H33	38648	44410.4	RW	ESC key configuration	WORD		0...8	num
V4	V4-H41	38208	44411.6	RW	Configuration input Pb1 (0=Disable, 1=DI, 2=H00)	WORD		0/1/2	num





FOLDER	LABEL	PAR. ADDRESS VALUE	PAR. ADDRESS Vis.	R/W	DESCRIPTION	DATA SIZE	CPL	RANGE	UM
V4	V4-H42	38210	44412	RW	Configuration input Pb2 (0=Disable, 1=DI, 2=H00)	WORD		0/1/2	num
V4	V4-H43	38212	44412.2	RW	Configuration input Pb3 (0=Disable, 1=DI, 2=H00)	WORD		0/1/2	num
V4	V4-H44	38214	44412.4	RW	Configuration input Pb4 (0=Disable, 1=DI, 2=H00)	WORD		0/1/2	num
V4	V4-H45	38216	44412.6	RW	Configuration input Pb5 (0=Disable, 1=DI, 2=H00)	WORD		0/1/2	num
V4	V4-H50	38264	44413.4	RW	Configuration Type of Analogue Output	WORD		0/1	num
V4	V4-H51	38266	44413.6	RW	Regulator associated to analogue output	WORD		0/1	num
V4	V4-H68	38268	44414	RW	Clock Present	WORD		0/1	num
V4	V4-H70	38224	44414.2	RW	Select probe 1 for virtual probe	WORD		0...5	num
V4	V4-H71	38226	44414.4	RW	Select probe 2 for virtual probe	WORD		0...5	num
V4	V4-H72	38228	44414.6	RW	% calculation virtual probe day	WORD		0...100	%
V4	V4-H73	38230	44415	RW	% calculation virtual probe night	WORD		0...100	%
V4	V4-UL	---	44420	RW	Parameter transfer function visibility (Device -> Copy Card)	2 BIT		0...3	num
V4	V4-dL	---	44420.2	RW	Parameter transfer function visibility (Copy Card -> Device)	2 BIT		0...3	num
V4	V4-Fr	---	44420.4	RW	Format Copy Card function visibility	2 BIT		0...3	num
<b>APPLICATION 5 PARAMETERS</b>									
	V5-SP1	39166	44544.6	RW	Setpoint	WORD		V5-LS1...V5-HS1	°C/°F
	V5-SP2	39170	44545.2	RW	Thermostat 2 setpoint	WORD		V5-LS2...V5-HS2	°C/°F
V5	V5-rE	39160	44544	RW	Regulation mode	WORD		0...4	num
V5	V5-rP1	39162	44544.2	RW	Regulation probe 1	WORD		0...7	num
V5	V5-rP2	39164	44544.4	RW	Thermostat 2 regulation probe	WORD		0...7	num
V5	V5-dF1	39168	44545	RW	Differential/proportional band	WORD		-58.0...302	°C/°F
V5	V5-dF2	39172	44545.4	RW	Thermostat 2 differential	WORD		-58.0...302	°C/°F
V5	V5-Stt	39178	44545.6	RW	Differential control mode	WORD		0/1	num
V5	V5-HS1	39184	44546	RW	SP1 maximum value	WORD		V5-LS1...V5-HdL	°C/°F
V5	V5-LS1	39186	44546.2	RW	SP1 minimum value	WORD		V5-LdL...V5-HS1	°C/°F
V5	V5-HS2	39188	44546.4	RW	SP2 maximum value	WORD		V5-LS2...V5-HdL	°C/°F
V5	V5-LS2	39190	44546.6	RW	SP2 minimum value	WORD		V5-LdL...V5-HS2	°C/°F
V5	V5-HC1	39180	44547	RW	Thermostat 1 mode	WORD		0/1	num
V5	V5-HC2	39182	44547.2	RW	Thermostat 2 mode	WORD		0/1	num
V5	V5-CC	39220	44547.4	RW	Double power step control	WORD		0/1	num
V5	V5-Cit	39200	44547.6	RW	Minimum compressor ON time	WORD		0...250	min
V5	V5-CAt	39202	44548	RW	Maximum compressor ON time	WORD		0...250	min
V5	V5-Ont	39212	44548.2	RW	ON time for faulty probe	WORD		0...250	min
V5	V5-OfT	39214	44548.4	RW	OFF time for faulty probe	WORD		0...250	min
V5	V5-dOn	39204	44548.6	RW	Switch on delay	WORD		0...250	sec
V5	V5-dOF	39206	44549	RW	Delay after switching off	WORD		0...250	min
V5	V5-dbi	39208	44549.2	RW	Delay between switch-ons	WORD		0...250	min
V5	V5-OdO	39210	44549.4	RW	Output delay from power-on	WORD		0...250	min
V5	V5-CP2	39216	44549.6	RW	Compressor 2 switch-on delay	WORD		0...250	sec
V5	V5-CS2	39218	44550	RW	Power step 2 switch-on delay	WORD		0...250	min
V5	V5-CFP	39378	44550.2	RW	Preventilation time	WORD		0...255	sec
V5	V5-CFd	39380	44550.4	RW	Fan mode	WORD		0/1	num
V5	V5-OF1	39222	44550.6	RW	Forced remote offset	WORD		-50.0...50.0	°C/°F
V5	V5-dP1	39224	44551	RW	Selection defrost probe 1	WORD		0...7	num
V5	V5-dP2	39226	44551.2	RW	Selection defrost probe 2	WORD		0...7	num
V5	V5-dtY	39232	44551.4	RW	Defrost mode	WORD		0...4	num
V5	V5-dFt	39228	44551.6	RW	Defrost activation mode with two probes	WORD		0/1/2	num
V5	V5-dit	39234	44552	RW	Interval between defrost cycles	WORD		0...250	hours
V5	V5-dt1	39240	44552.2	RW	Unit of measurement for defrost interval	WORD		0/1/2	num
V5	V5-dt2	39242	44552.4	RW	Unit of measure for defrost duration	WORD		0/1/2	num
V5	V5-dCt	39230	44552.6	RW	Defrost interval count mode	WORD		0...5	num
V5	V5-dOH	39244	44553	RW	Defrost interval count mode	WORD		0...250	min
V5	V5-dE1	39236	44553.2	RW	Evaporator 1 defrost time-out	WORD		1...250	min
V5	V5-dE2	39238	44553.4	RW	Evaporator 2 defrost time-out	WORD		1...250	min
V5	V5-dS1	39248	44553.6	RW	Probe 1 end of defrost temperature	WORD		-58.0...302	°C/°F
V5	V5-dS2	39250	44554	RW	Probe 2 end of defrost temperature	WORD		-58.0...302	°C/°F



FOLDER	LABEL	PAR. ADDRESS VALUE	PAR. ADDRESS Vis.	R/W	DESCRIPTION	DATA SIZE	CPL	RANGE	UM
V5	V5-dSS	39246	44554.2	RW	Start defrost temperature threshold	WORD		-58.0...302	°C/°F
V5	V5-dPO	39252	44554.4	RW	Request defrost activation from power on	WORD		0/1	num
V5	V5-tcd	39254	44554.6	RW	Min. compressor ON or OFF time before defrost	WORD		-60...60	min
V5	V5-ndE	39256	44555	RW	Minimum defrost time (for hot gas only)	WORD		0...250	min
V5	V5-PdC	39258	44555.2	RW	Hot gas extraction time at defrost end	WORD		0...250	min
V5	V5-tPd	39262	44555.4	RW	Pump down time before defrost startup	WORD		0...255	min
V5	V5-dPH	39140	44555.6	RW	Start time for periodical defrost	WORD		0...24	hours
V5	V5-dPn	39142	44556	RW	Start time minutes for periodical defrost	WORD		0...59	min
V5	V5-dPd	39144	44556.2	RW	Periodical defrost interval duration	WORD		1...7	Day
V5	V5-Fd1	39038	44556.4	RW	Weekend/public holiday 1	WORD		0...7	num
V5	V5-Fd2	39040	44556.6	RW	Weekend/public holiday 2	WORD		0...7	num
V5	V5-Edt	39042	44557	RW	Customized duration and temperature for each event	WORD		0/1	num
V5	V5-d1H	39044	44557.2	RW	Start time weekday defrost 1	WORD		0...24	hours
V5	V5-d1n	39046	44557.4	RW	Start time minutes weekday defrost 1	WORD		0...59	min
V5	V5-d1t	39048	44557.6	RW	Weekday defrost 1 duration	WORD		0...250	min
V5	V5-d1S	39050	44558	RW	End of weekday defrost 1 temperature	WORD		-58.0...302	°C/°F
V5	V5-d2H	39052	44558.2	RW	Start time weekday defrost 2	WORD		V5-d1H...24	hours
V5	V5-d2n	39054	44558.4	RW	Start time minutes weekday defrost 2	WORD		0...59	min
V5	V5-d2t	39056	44558.6	RW	Weekday defrost 2 duration	WORD		0...250	min
V5	V5-d2S	39058	44559	RW	End of weekday defrost 2 temperature	WORD		-58.0...302	°C/°F
V5	V5-d3H	39060	44559.2	RW	Start time weekday defrost 3	WORD		V5-d2H...24	hours
V5	V5-d3n	39062	44559.4	RW	Start time minutes weekday defrost 3	WORD		0...59	min
V5	V5-d3t	39064	44559.6	RW	Weekday defrost 3 duration	WORD		0...250	min
V5	V5-d3S	39066	44560	RW	End of weekday defrost 3 temperature	WORD		-58.0...302	°C/°F
V5	V5-d4H	39068	44560.2	RW	Start time weekday defrost 4	WORD		V5-d3H...24	hours
V5	V5-d4n	39070	44560.4	RW	Start time minutes weekday defrost 4	WORD		0...59	min
V5	V5-d4t	39072	44560.6	RW	Weekday defrost 4 duration	WORD		0...250	min
V5	V5-d4S	39074	44561	RW	End of weekday defrost 4 temperature	WORD		-58.0...302	°C/°F
V5	V5-d5H	39076	44561.2	RW	Start time weekday defrost 5	WORD		V5-d4H...24	hours
V5	V5-d5n	39078	44561.4	RW	Start time minutes weekday defrost 5	WORD		0...59	min
V5	V5-d5t	39080	44561.6	RW	Weekday defrost 5 duration	WORD		0...250	min
V5	V5-d5S	39082	44562	RW	End of weekday defrost 5 temperature	WORD		-58.0...302	°C/°F
V5	V5-d6H	39084	44562.2	RW	Start time weekday defrost 6	WORD		V5-d5H...24	hours
V5	V5-d6n	39086	44562.4	RW	Start time minutes weekday defrost 6	WORD		0...59	min
V5	V5-d6t	39088	44562.6	RW	Weekday defrost 6 duration	WORD		0...250	min
V5	V5-d6S	39090	44563	RW	End of weekday defrost 6 temperature	WORD		-58.0...302	°C/°F
V5	V5-F1H	39092	44563.2	RW	Start time weekend/public holiday defrost 1	WORD		0...24	hours
V5	V5-F1n	39094	44563.4	RW	Weekend/public holiday defrost 1 start time minutes	WORD		0...59	min
V5	V5-F1t	39096	44563.6	RW	Weekend/public holiday defrost 1 duration	WORD		0...250	min
V5	V5-F1S	39098	44564	RW	End of weekend/public holiday defrost 1 temperature	WORD		-58.0...302	°C/°F
V5	V5-F2H	39100	44564.2	RW	Start time weekend/public holiday defrost 2	WORD		V5-F1H...24	hours
V5	V5-F2n	39102	44564.4	RW	Weekend/public holiday defrost 2 start time minutes	WORD		0...59	min
V5	V5-F2t	39104	44564.6	RW	Weekend/public holiday defrost 2 duration	WORD		0...250	min
V5	V5-F2S	39106	44565	RW	End of weekend/public holiday defrost 1 temperature	WORD		-58.0...302	°C/°F
V5	V5-F3H	39108	44565.2	RW	Start time weekend/public holiday defrost 3	WORD		V5-F2H...24	hours
V5	V5-F3n	39110	44565.4	RW	Weekend/public holiday defrost 3 start time minutes	WORD		0...59	min
V5	V5-F3t	39112	44565.6	RW	Weekend/public holiday defrost 3 duration	WORD		0...250	min
V5	V5-F3S	39114	44566	RW	End of weekend/public holiday defrost 1 temperature	WORD		-58.0...302	°C/°F
V5	V5-F4H	39116	44566.2	RW	Start time weekend/public holiday defrost 4	WORD		V5-F3H...24	hours
V5	V5-F4n	39118	44566.4	RW	Weekend/public holiday defrost 4 start time minutes	WORD		0...59	min
V5	V5-F4t	39120	44566.6	RW	Weekend/public holiday defrost 4 duration	WORD		0...250	min
V5	V5-F4S	39122	44567	RW	End of weekend/public holiday defrost 1 temperature	WORD		-58.0...302	°C/°F
V5	V5-F5H	39124	44567.2	RW	Start time weekend/public holiday defrost 5	WORD		V5-F4H...24	hours
V5	V5-F5n	39126	44567.4	RW	Weekend/public holiday defrost 5 start time minutes	WORD		0...59	min
V5	V5-F5t	39128	44567.6	RW	Weekend/public holiday defrost 5 duration	WORD		0...250	min
V5	V5-F5S	39130	44568	RW	End of weekend/public holiday defrost 1 temperature	WORD		-58.0...302	°C/°F



FOLDER	LABEL	PAR. ADDRESS VALUE	PAR. ADDRESS Vis.	R/W	DESCRIPTION	DATA SIZE	CPL	RANGE	UM
V5	V5-F6H	39132	44568.2	RW	Start time weekend/public holiday defrost 6	WORD		V5-F5H...24	hours
V5	V5-F6n	39134	44568.4	RW	Weekend/public holiday defrost 6 start time minutes	WORD		0...59	min
V5	V5-F6t	39136	44568.6	RW	Weekend/public holiday defrost 6 duration	WORD		0...250	min
V5	V5-F6S	39138	44569	RW	End of weekend/public holiday defrost 6 temperature	WORD		-58.0...302	°C/°F
V5	V5-FP1	39264	44569.2	RW	Evaporator fan probe in normal mode	WORD		0...7	num
V5	V5-FP2	39266	44569.4	RW	Evaporator fan probe during defrost stage	WORD		0...7	num
V5	V5-FPt	39268	44569.6	RW	FSt parameter mode	WORD		0/1	num
V5	V5-FSt	39270	44570	RW	Block fan temperature	WORD		-58.0...302	°C/°F
V5	V5-FAd	39272	44570.2	RW	Fan differential	WORD		0.1...25.0	°C/°F
V5	V5-Fdt	39274	44570.4	RW	Fan activation delay after compressor start	WORD		0...250	min
V5	V5-dt	39284	44570.6	RW	Dripping time	WORD		0...250	min
V5	V5-dFd	39280	44571	RW	Evaporator fan mode during defrost	WORD		0/1	num
V5	V5-FCO	39278	44571.2	RW	Evaporator fan mode	WORD		0...3	num
V5	V5-FdC	39276	44571.6	RW	Fan switch off delay after compressor stop	WORD		0...250	min
V5	V5-FOn	39286	44572	RW	Fan ON time in Duty Cycle	WORD		0...250	min
V5	V5-FOF	39288	44572.2	RW	Fan OFF time in Duty Cycle	WORD		0...250	min
V5	V5-Fnn	39290	44572.4	RW	Duty cycle on time during night mode	WORD		0...250	min
V5	V5-FnF	39292	44572.6	RW	Duty cycle off time during night mode	WORD		0...250	min
V5	V5-rA1	39320	44573	RW	Temperature alarm probe 1 selection	WORD		0...6	num
V5	V5-rA2	39322	44573.2	RW	Temperature alarm probe 2 selection	WORD		0...6	num
V5	V5-Att	39324	44573.4	RW	Parameter HAL and LAL mode	WORD		0/1	num
V5	V5-AFd	39326	44573.6	RW	Alarm setpoint differential	WORD		0.1...25.0	°C/°F
V5	V5-HA1	39328	44574	RW	Probe 1 maximum alarm	WORD		V5-LA1...302	°C/°F
V5	V5-LA1	39330	44574.2	RW	Probe 1 minimum alarm	WORD		-58.0...V5-HA1	°C/°F
V5	V5-HA2	39332	44574.4	RW	Probe 2 maximum alarm	WORD		V5-LA2...302	°C/°F
V5	V5-LA2	39334	44574.6	RW	Probe 2 minimum alarm	WORD		-58.0...V5-HA2	°C/°F
V5	V5-PAO	39336	44575	RW	Exclude alarm at switch on	WORD		0...10	hours
V5	V5-dAO	39340	44575.2	RW	Exclude alarm after defrost	WORD		0...250	min
V5	V5-OAO	39338	44575.4	RW	Alarm signal delay after closing door	WORD		0...10	hours
V5	V5-tdO	39428	44575.6	RW	Open door disabling time	WORD		0...250	num
V5	V5-tA1	39342	44576	RW	LA1 and HA1 alarm signal delay	WORD		0...250	min
V5	V5-tA2	39344	44576.2	RW	LA2 and HA2 alarm signal delay	WORD		0...250	min
V5	V5-dAt	39260	44576.4	RW	Enable alarm at end of defrost	WORD		0/1	num
V5	V5-EAL	39348	44576.6	RW	External alarm switches off utilities	WORD		0/1/2	num
V5	V5-tP	39430	44577	RW	Enable alarm overriding from any key	WORD		0/1	num
V5	V5-Art	39318	44577.2	RW	Alarm activation period supervisor link	WORD		0...250	min*10
V5	V5-dSd	39312	44577.4	RW	Enable light relay from door switch	WORD		0/1	num
V5	V5-dLt	39314	44577.6	RW	Delay disabling light relay	WORD		0...250	min
V5	V5-OFL	39316	44578	RW	Light key always disables light relay	WORD		0/1	num
V5	V5-dOd	39346	44578.2	RW	Door switch turns off utilities	WORD		0...3	num
V5	V5-dOA	39350	44578.4	RW	Action forced by digital input	WORD		0...5	num
V5	V5-PEA	39352	44578.6	RW	DI selected to block/release resources	WORD		0...3	num
V5	V5-dCO	39354	44579	RW	Delay to activate/switch off compressor evap. fan	WORD		0...250	min
V5	V5-dFO	39356	44579.2	RW	Delay to activate/switch off evap. fan	WORD		0...250	min
V5	V5-ASb	39408	44579.4	RW	Key/AUX input/Light active when OFF	WORD		0/1	num
V5	V5-L00	38912	44579.6	RW	Shared probe	WORD		0...6	num
V5	V5-L01	38914	44580	RW	Display value shared	WORD		0/1/2	num
V5	V5-L02	38916	44580.2	RW	Send setpoint value when modified	WORD		0/1	num
V5	V5-L03	38918	44580.4	RW	Send defrost request	WORD		0/1	num
V5	V5-L04	38920	44580.6	RW	End defrost mode	WORD		0/1	num
V5	V5-L05	38922	44581	RW	Synchronization of Stand-By command	WORD		0/1	num
V5	V5-L06	38924	44581.2	RW	Synchronization of light command	WORD		0/1	num
V5	V5-L07	38926	44581.4	RW	Synchronization of reduced setpoint command	WORD		0/1	num
V5	V5-L08	38928	44581.6	RW	Synchronization of AUX command	WORD		0/1	num
V5	V5-L10	39432	44582.2	RW	Wait for end of dependent defrost timeout	WORD		0...250	min
V5	V5-PEn	39308	44582.4	RW	Number of errors allowed	WORD		0...15	num



FOLDER	LABEL	PAR. ADDRESS VALUE	PAR. ADDRESS Vis.	R/W	DESCRIPTION	DATA SIZE	CPL	RANGE	UM
V5	V5-PEi	39310	44582.6	RW	Error count interval	WORD		1...250	min
V5	V5-dcS	39300	44583	RW	Deep Cooling Setpoint	WORD		-58.0...302	°C/°F
V5	V5-tdc	39302	44583.2	RW	Deep Cooling duration	WORD		0...250	min
V5	V5-dcc	39304	44583.4	RW	Waiting time to start defrost cycle	WORD		0...250	min
V5	V5-ESt	39158	44583.6	RW	Type of Energy Saving	WORD		0...4	num
V5	V5-ESF	39294	44584	RW	Night mode enabled	WORD		0/1	num
V5	V5-Cdt	39296	44584.2	RW	Min. door closed time to activate reduced setpoint	WORD		0...255	min*10
V5	V5-ESo	39298	44584.4	RW	Cumulative door open time	WORD		0...10	num
V5	V5-OS1	39192	44584.6	RW	Offset SP1	WORD		-50.0...50.0	°C/°F
V5	V5-OS2	39194	44585	RW	Offset SP2	WORD		-50.0...50.0	°C/°F
V5	V5-Od1	39196	44585.2	RW	Door energy saving offset 1	WORD		-50.0...50.0	°C/°F
V5	V5-Od2	39198	44585.4	RW	Door energy saving offset 2	WORD		-50.0...50.0	°C/°F
V5	V5-dn1	39174	44585.6	RW	dn1 Differential in energy saving mode 1	WORD		-58.0...302	°C/°F
V5	V5-dn2	39176	44586	RW	dn2 Differential in energy saving mode 2	WORD		-58.0...302	°C/°F
V5	V5-EdH	39146	44586.2	RW	Start time weekday Energy Saving	WORD		0...24	hours
V5	V5-Edn	39148	44586.4	RW	Weekday Energy Saving start time minutes	WORD		0...59	min
V5	V5-Edd	39150	44586.6	RW	Weekday Energy Saving event duration	WORD		1...72	hours
V5	V5-EFH	39152	44587	RW	Weekend/public holiday Energy Saving start time	WORD		0...24	hours
V5	V5-EFn	39154	44587.2	RW	Weekend/public holiday Energy Saving start time minutes	WORD		0...59	min
V5	V5-EFd	39156	44587.4	RW	Weekend/public holiday Energy Saving event duration	WORD		1...72	hours
V5	V5-FH	39358	44587.6	RW	Regulation mode	WORD		0...7	num
V5	V5-FHt	39362	44588	RW	Frame heater period	WORD		1...2500	sec*10
V5	V5-FH0	39364	44588.2	RW	Frame heater setpoint	WORD		-58.0...302	°C/°F
V5	V5-FH1	39366	44588.4	RW	Frame heater offset	WORD		0.0...25.0	°C/°F
V5	V5-FH2	39368	44588.6	RW	Frame heater band	WORD		0.0...25.0	°C/°F
V5	V5-FH3	39370	44589	RW	Min. percentage	WORD		0...100	%
V5	V5-FH4	39372	44589.2	RW	Maximum percentage/Duty Cycle Day	WORD		0...100	%
V5	V5-FH5	39374	44589.4	RW	Maximum percentage/Duty Cycle Night (ES)	WORD		0...100	%
V5	V5-FH6	39376	44589.6	RW	Percentage during defrost	WORD		0...100	%
V5	V5-LOC	39382	44590	RW	Keypad lock	WORD		0/1	num
V5	V5-PS1	39384	44590.2	RW	Password 1	WORD		0...250	num
V5	V5-PS2	39386	44590.4	RW	Password 2	WORD		0...250	num
V5	V5-ndt	39388	44590.6	RW	Display with decimal point	WORD		0/1	num
V5	V5-CA1	39000	44591	RW	Calibration Pb1	WORD		-30.0...30.0	°C/°F
V5	V5-CA2	39002	44591.2	RW	Calibration Pb2	WORD		-30.0...30.0	°C/°F
V5	V5-CA3	39004	44591.4	RW	Calibration Pb3	WORD		-30.0...30.0	°C/°F
V5	V5-CA4	39006	44591.6	RW	Calibration Pb4	WORD		-30.0...30.0	°C/°F
V5	V5-CA5	39008	44592	RW	Calibration Pb5	WORD		-30.0...30.0	°C/°F
V5	V5-LdL	39390	44592.6	RW	Minimum value displayable	WORD		-58.0...V5-HdL	°C/°F
V5	V5-HdL	39392	44593	RW	Maximum value displayable	WORD		V5-LdL...302	°C/°F
V5	V5-ddL	39394	44593.2	RW	Block display during defrost	WORD		0/1/2	num
V5	V5-Ldd	39396	44593.4	RW	"ddL" Release Time-Out	WORD		0...250	min
V5	V5-dro	39398	44593.6	RW	°C/°F selection (0=°C, 1=°F)	WORD		0/1	num
V5	V5-ddd	39402	44594.2	RW	Main Display	WORD		0...7	num
V5	V5-ddE	39404	44594.4	RW	Main display on ECHO	WORD		0...7	num
V5	V5-rPH	39306	44594.6	RW	Select HACCP alarm probe	WORD		0...5	num
V5	V5-H00	38932	44595	RW	Type of probe Pb1-Pb2-Pb3-Pb4-Pb5 (0=NTC, 1=PTC, 2=PT1000)	WORD		0/1/2	num
V5	V5-H02	39406	44595.2	RW	Key activation time	WORD		0...250	sec
V5	V5-H08	39410	44595.4	RW	Stand-By mode	WORD		0/1/2	num
V5	V5-H11	38942	44595.6	RW	Configuration input DI1	WORD		-17...17	num
V5	V5-H12	38944	44596	RW	Configuration input DI2	WORD		-17...17	num
V5	V5-H13	38946	44596.2	RW	Configuration input DI3	WORD		-17...17	num
V5	V5-H14	38948	44596.4	RW	Configuration input DI4	WORD		-17...17	num
V5	V5-H15	38950	44596.6	RW	Configuration input DI5	WORD		-17...17	num
V5	V5-H16	38952	44597	RW	Configuration input DI6	WORD		-17...17	num
V5	V5-H17	38954	44597.2	RW	Configuration input DI7	WORD		-17...17	num



FOLDER	LABEL	PAR. ADDRESS VALUE	PAR. ADDRESS Vis.	R/W	DESCRIPTION	DATA SIZE	CPL	RANGE	UM
V5	V5-H18	38956	44597.4	RW	Configuration input DI8	WORD		-17...17	num
V5	V5-dti	38974	44597.6	RW	Unit of measure for digital inputs 1 and 2	WORD		0/1	num
V5	V5-d11	38958	44598	RW	Activation delay for digital input 1	WORD		0...255	min/sec
V5	V5-d12	38960	44598.2	RW	Activation delay for digital input 2	WORD		0...255	min/sec
V5	V5-d13	38962	44598.4	RW	Activation delay for digital input 3	WORD		0...255	min
V5	V5-d14	38964	44598.6	RW	Activation delay for digital input 4	WORD		0...255	min
V5	V5-d15	38966	44599	RW	Activation delay for digital input 5	WORD		0...255	min
V5	V5-d16	38968	44599.2	RW	Activation delay for digital input 6	WORD		0...255	min
V5	V5-d17	38970	44599.4	RW	Activation delay for digital input 7	WORD		0...255	min
V5	V5-d18	38972	44599.6	RW	Activation delay for digital input 8	WORD		0...255	min
V5	V5-H21	39016	44600	RW	Configuration Relay 1	WORD		0...13	num
V5	V5-H22	39018	44600.2	RW	Configuration Relay 2	WORD		0...13	num
V5	V5-H23	39020	44600.4	RW	Configuration Relay 3	WORD		0...13	num
V5	V5-H24	39022	44600.6	RW	Configuration Relay 4	WORD		0...13	num
V5	V5-H25	39024	44601	RW	Configuration Relay 5	WORD		0...13	num
V5	V5-H26	39026	44601.2	RW	Configuration Relay 6	WORD		0...13	num
V5	V5-H27	39028	44601.4	RW	Configuration Relay 7	WORD		0...13	num
V5	V5-H29	39030	44601.6	RW	Enable buzzer	WORD		0/1	num
V5	V5-H31	39412	44602	RW	Configuration of UP key	WORD		0...8	num
V5	V5-H32	39414	44602.2	RW	Configuration of DOWN key	WORD		0...8	num
V5	V5-H33	39416	44602.4	RW	ESC key configuration	WORD		0...8	num
V5	V5-H41	38976	44603.6	RW	Configuration input Pb1 (0=Disable, 1=DI, 2=H00)	WORD		0/1/2	num
V5	V5-H42	38978	44604	RW	Configuration input Pb2 (0=Disable, 1=DI, 2=H00)	WORD		0/1/2	num
V5	V5-H43	38980	44604.2	RW	Configuration input Pb3 (0=Disable, 1=DI, 2=H00)	WORD		0/1/2	num
V5	V5-H44	38982	44604.4	RW	Configuration input Pb4 (0=Disable, 1=DI, 2=H00)	WORD		0/1/2	num
V5	V5-H45	38984	44604.6	RW	Configuration input Pb5 (0=Disable, 1=DI, 2=H00)	WORD		0/1/2	num
V5	V5-H50	39032	44605.4	RW	Configuration Type of Analogue Output	WORD		0/1	num
V5	V5-H51	39034	44605.6	RW	Regulator associated to analogue output	WORD		0/1	num
V5	V5-H68	39036	44606	RW	Clock Present	WORD		0/1	num
V5	V5-H70	38992	44606.2	RW	Select probe 1 for virtual probe	WORD		0...5	num
V5	V5-H71	38994	44606.4	RW	Select probe 2 for virtual probe	WORD		0...5	num
V5	V5-H72	38996	44606.6	RW	% calculation virtual probe day	WORD		0...100	%
V5	V5-H73	38998	44607	RW	% calculation virtual probe night	WORD		0...100	%
V5	V5-UL	---	44612	RW	Parameter transfer function visibility (Device -> Copy Card)	2 BIT		0...3	num
V5	V5-dL	---	44612.2	RW	Parameter transfer function visibility (Copy Card -> Device)	2 BIT		0...3	num
V5	V5-Fr	---	44612.4	RW	Format Copy Card function visibility	2 BIT		0...3	num

#### APPLICATION 6 PARAMETERS

	V6-SP1	39934	44736.6	RW	Setpoint	WORD		V6-LS1...V6-HS1	°C/°F
	V6-SP2	39938	44737.2	RW	Thermostat 2 setpoint	WORD		V6-LS2...V6-HS2	°C/°F
V6	V6-rE	39928	44736	RW	Regulation mode	WORD		0...4	num
V6	V6-rP1	39930	44736.2	RW	Regulation probe 1	WORD		0...7	num
V6	V6-rP2	39932	44736.4	RW	Thermostat 2 regulation probe	WORD		0...7	num
V6	V6-dF1	39936	44737	RW	Differential/proportional band	WORD		-58.0...302	°C/°F
V6	V6-dF2	39940	44737.4	RW	Thermostat 2 differential	WORD		-58.0...302	°C/°F
V6	V6-Stt	39946	44737.6	RW	Differential control mode	WORD		0/1	num
V6	V6-HS1	39952	44738	RW	SP1 maximum value	WORD		V6-LS1...V6-HdL	°C/°F
V6	V6-LS1	39954	44738.2	RW	SP1 minimum value	WORD		V6-LdL...V6-HS1	°C/°F
V6	V6-HS2	39956	44738.4	RW	SP2 maximum value	WORD		V6-LS2...V6-HdL	°C/°F
V6	V6-LS2	39958	44738.6	RW	SP2 minimum value	WORD		V6-LdL...V6-HS2	°C/°F
V6	V6-HC1	39948	44739	RW	Thermostat 1 mode	WORD		0/1	num
V6	V6-HC2	39950	44739.2	RW	Thermostat 2 mode	WORD		0/1	num
V6	V6-CC	39988	44739.4	RW	Double power step control	WORD		0/1	num
V6	V6-Cit	39968	44739.6	RW	Minimum compressor ON time	WORD		0...250	min
V6	V6-CAt	39970	44740	RW	Maximum compressor ON time	WORD		0...250	min
V6	V6-Ont	39980	44740.2	RW	ON time for faulty probe	WORD		0...250	min
V6	V6-OfT	39982	44740.4	RW	OFF time for faulty probe	WORD		0...250	min



FOLDER	LABEL	PAR. ADDRESS VALUE	PAR. ADDRESS Vis.	R/W	DESCRIPTION	DATA SIZE	CPL	RANGE	UM
V6	V6-dOn	39972	44740.6	RW	Switch on delay	WORD		0...250	sec
V6	V6-dOF	39974	44741	RW	Delay after switching off	WORD		0...250	min
V6	V6-dbi	39976	44741.2	RW	Delay between switch-ons	WORD		0...250	min
V6	V6-OdO	39978	44741.4	RW	Output delay from power-on	WORD		0...250	min
V6	V6-CP2	39984	44741.6	RW	Compressor 2 switch-on delay	WORD		0...250	sec
V6	V6-CS2	39986	44742	RW	Power step 2 switch-on delay	WORD		0...250	min
V6	V6-CFP	40146	44742.2	RW	Preventilation time	WORD		0...255	sec
V6	V6-CFd	40148	44742.4	RW	Fan mode	WORD		0/1	num
V6	V6-OF1	39990	44742.6	RW	Forced remote offset	WORD		-50.0...50.0	°C/°F
V6	V6-dP1	39992	44743	RW	Selection defrost probe 1	WORD		0...7	num
V6	V6-dP2	39994	44743.2	RW	Selection defrost probe 2	WORD		0...7	num
V6	V6-dtY	40000	44743.4	RW	Defrost mode	WORD		0...4	num
V6	V6-dFt	39996	44743.6	RW	Defrost activation mode with two probes	WORD		0/1/2	num
V6	V6-dit	40002	44744	RW	Interval between defrost cycles	WORD		0...250	hours
V6	V6-dt1	40008	44744.2	RW	Unit of measurement for defrost interval	WORD		0/1/2	num
V6	V6-dt2	40010	44744.4	RW	Unit of measure for defrost duration	WORD		0/1/2	num
V6	V6-dCt	39998	44744.6	RW	Defrost interval count mode	WORD		0...5	num
V6	V6-dOH	40012	44745	RW	Defrost interval count mode	WORD		0...250	min
V6	V6-dE1	40004	44745.2	RW	Evaporator 1 defrost time-out	WORD		1...250	min
V6	V6-dE2	40006	44745.4	RW	Evaporator 2 defrost time-out	WORD		1...250	min
V6	V6-dS1	40016	44745.6	RW	Probe 1 end of defrost temperature	WORD		-58.0...302	°C/°F
V6	V6-dS2	40018	44746	RW	Probe 2 end of defrost temperature	WORD		-58.0...302	°C/°F
V6	V6-dSS	40014	44746.2	RW	Start defrost temperature threshold	WORD		-58.0...302	°C/°F
V6	V6-dPO	40020	44746.4	RW	Request defrost activation from power on	WORD		0/1	num
V6	V6-tcd	40022	44746.6	RW	Min. compressor ON or OFF time before defrost	WORD		-60...60	min
V6	V6-ndE	40024	44747	RW	Minimum defrost time (for hot gas only)	WORD		0...250	min
V6	V6-PdC	40026	44747.2	RW	Hot gas extraction time at defrost end	WORD		0...250	min
V6	V6-tPd	40030	44747.4	RW	Pump down time before defrost startup	WORD		0...255	min
V6	V6-dPH	39908	44747.6	RW	Start time for periodical defrost	WORD		0...24	hours
V6	V6-dPn	39910	44748	RW	Start time minutes for periodical defrost	WORD		0...59	min
V6	V6-dPd	39912	44748.2	RW	Periodical defrost interval duration	WORD		1...7	Day
V6	V6-Fd1	39806	44748.4	RW	Weekend/public holiday 1	WORD		0...7	num
V6	V6-Fd2	39808	44748.6	RW	Weekend/public holiday 2	WORD		0...7	num
V6	V6-Edt	39810	44749	RW	Customized duration and temperature for each event	WORD		0/1	num
V6	V6-d1H	39812	44749.2	RW	Start time weekday defrost 1	WORD		0...24	hours
V6	V6-d1n	39814	44749.4	RW	Start time minutes weekday defrost 1	WORD		0...59	min
V6	V6-d1t	39816	44749.6	RW	Weekday defrost 1 duration	WORD		0...250	min
V6	V6-d1S	39818	44750	RW	End of weekday defrost 1 temperature	WORD		-58.0...302	°C/°F
V6	V6-d2H	39820	44750.2	RW	Start time weekday defrost 2	WORD		V6-d1H...24	hours
V6	V6-d2n	39822	44750.4	RW	Start time minutes weekday defrost 2	WORD		0...59	min
V6	V6-d2t	39824	44750.6	RW	Weekday defrost 2 duration	WORD		0...250	min
V6	V6-d2S	39826	44751	RW	End of weekday defrost 2 temperature	WORD		-58.0...302	°C/°F
V6	V6-d3H	39828	44751.2	RW	Start time weekday defrost 3	WORD		V6-d2H...24	hours
V6	V6-d3n	39830	44751.4	RW	Start time minutes weekday defrost 3	WORD		0...59	min
V6	V6-d3t	39832	44751.6	RW	Weekday defrost 3 duration	WORD		0...250	min
V6	V6-d3S	39834	44752	RW	End of weekday defrost 3 temperature	WORD		-58.0...302	°C/°F
V6	V6-d4H	39836	44752.2	RW	Start time weekday defrost 4	WORD		V6-d3H...24	hours
V6	V6-d4n	39838	44752.4	RW	Start time minutes weekday defrost 4	WORD		0...59	min
V6	V6-d4t	39840	44752.6	RW	Weekday defrost 4 duration	WORD		0...250	min
V6	V6-d4S	39842	44753	RW	End of weekday defrost 4 temperature	WORD		-58.0...302	°C/°F
V6	V6-d5H	39844	44753.2	RW	Start time weekday defrost 5	WORD		V6-d4H...24	hours
V6	V6-d5n	39846	44753.4	RW	Start time minutes weekday defrost 5	WORD		0...59	min
V6	V6-d5t	39848	44753.6	RW	Weekday defrost 5 duration	WORD		0...250	min
V6	V6-d5S	39850	44754	RW	End of weekday defrost 5 temperature	WORD		-58.0...302	°C/°F
V6	V6-d6H	39852	44754.2	RW	Start time weekday defrost 6	WORD		V6-d5H...24	hours
V6	V6-d6n	39854	44754.4	RW	Start time minutes weekday defrost 6	WORD		0...59	min



FOLDER	LABEL	PAR. ADDRESS VALUE	PAR. ADDRESS Vis.	R/W	DESCRIPTION	DATA SIZE	CPL	RANGE	UM
V6	V6-d6t	39856	44754.6	RW	Weekday defrost 6 duration	WORD		0...250	min
V6	V6-d6S	39858	44755	RW	End of weekday defrost 6 temperature	WORD		-58.0...302	°C/°F
V6	V6-F1H	39860	44755.2	RW	Start time weekend/public holiday defrost 1	WORD		0...24	hours
V6	V6-F1n	39862	44755.4	RW	Weekend/public holiday defrost 1 start time minutes	WORD		0...59	min
V6	V6-F1t	39864	44755.6	RW	Weekend/public holiday defrost 1 duration	WORD		0...250	min
V6	V6-F1S	39866	44756	RW	End of weekend/public holiday defrost 1 temperature	WORD		-58.0...302	°C/°F
V6	V6-F2H	39868	44756.2	RW	Start time weekend/public holiday defrost 2	WORD		V6-F1H...24	hours
V6	V6-F2n	39870	44756.4	RW	Weekend/public holiday defrost 2 start time minutes	WORD		0...59	min
V6	V6-F2t	39872	44756.6	RW	Weekend/public holiday defrost 2 duration	WORD		0...250	min
V6	V6-F2S	39874	44757	RW	End of weekend/public holiday defrost 1 temperature	WORD		-58.0...302	°C/°F
V6	V6-F3H	39876	44757.2	RW	Start time weekend/public holiday defrost 3	WORD		V6-F2H...24	hours
V6	V6-F3n	39878	44757.4	RW	Weekend/public holiday defrost 3 start time minutes	WORD		0...59	min
V6	V6-F3t	39880	44757.6	RW	Weekend/public holiday defrost 3 duration	WORD		0...250	min
V6	V6-F3S	39882	44758	RW	End of weekend/public holiday defrost 1 temperature	WORD		-58.0...302	°C/°F
V6	V6-F4H	39884	44758.2	RW	Start time weekend/public holiday defrost 4	WORD		V6-F3H...24	hours
V6	V6-F4n	39886	44758.4	RW	Weekend/public holiday defrost 4 start time minutes	WORD		0...59	min
V6	V6-F4t	39888	44758.6	RW	Weekend/public holiday defrost 4 duration	WORD		0...250	min
V6	V6-F4S	39890	44759	RW	End of weekend/public holiday defrost 1 temperature	WORD		-58.0...302	°C/°F
V6	V6-F5H	39892	44759.2	RW	Start time weekend/public holiday defrost 5	WORD		V6-F4H...24	hours
V6	V6-F5n	39894	44759.4	RW	Weekend/public holiday defrost 5 start time minutes	WORD		0...59	min
V6	V6-F5t	39896	44759.6	RW	Weekend/public holiday defrost 5 duration	WORD		0...250	min
V6	V6-F5S	39898	44760	RW	End of weekend/public holiday defrost 1 temperature	WORD		-58.0...302	°C/°F
V6	V6-F6H	39900	44760.2	RW	Start time weekend/public holiday defrost 6	WORD		V6-F5H...24	hours
V6	V6-F6n	39902	44760.4	RW	Weekend/public holiday defrost 6 start time minutes	WORD		0...59	min
V6	V6-F6t	39904	44760.6	RW	Weekend/public holiday defrost 6 duration	WORD		0...250	min
V6	V6-F6S	39906	44761	RW	End of weekend/public holiday defrost 6 temperature	WORD		-58.0...302	°C/°F
V6	V6-FP1	40032	44761.2	RW	Evaporator fan probe in normal mode	WORD		0...7	num
V6	V6-FP2	40034	44761.4	RW	Evaporator fan probe during defrost stage	WORD		0...7	num
V6	V6-FPt	40036	44761.6	RW	FSt parameter mode	WORD		0/1	num
V6	V6-FSt	40038	44762	RW	Block fan temperature	WORD		-58.0...302	°C/°F
V6	V6-FAd	40040	44762.2	RW	Fan differential	WORD		0.1...25.0	°C/°F
V6	V6-Fdt	40042	44762.4	RW	Fan activation delay after compressor start	WORD		0...250	min
V6	V6-dt	40052	44762.6	RW	Dripping time	WORD		0...250	min
V6	V6-dFd	40048	44763	RW	Evaporator fan mode during defrost	WORD		0/1	num
V6	V6-FCO	40046	44763.2	RW	Evaporator fan mode	WORD		0...3	num
V6	V6-FdC	40044	44763.6	RW	Fan switch off delay after compressor stop	WORD		0...250	min
V6	V6-FOn	40054	44764	RW	Fan ON time in Duty Cycle	WORD		0...250	min
V6	V6-FOF	40056	44764.2	RW	Fan OFF time in Duty Cycle	WORD		0...250	min
V6	V6-Fnn	40058	44764.4	RW	Duty cycle on time during night mode	WORD		0...250	min
V6	V6-FnF	40060	44764.6	RW	Duty cycle off time during night mode	WORD		0...250	min
V6	V6-rA1	40088	44765	RW	Temperature alarm probe 1 selection	WORD		0...6	num
V6	V6-rA2	40090	44765.2	RW	Temperature alarm probe 2 selection	WORD		0...6	num
V6	V6-Att	40092	44765.4	RW	Parameter HAL and LAL mode	WORD		0/1	num
V6	V6-AFd	40094	44765.6	RW	Alarm setpoint differential	WORD		0.1...25.0	°C/°F
V6	V6-HA1	40096	44766	RW	Probe 1 maximum alarm	WORD		V6-LA1...302	°C/°F
V6	V6-LA1	40098	44766.2	RW	Probe 1 minimum alarm	WORD		-58.0...V6-HA1	°C/°F
V6	V6-HA2	40100	44766.4	RW	Probe 2 maximum alarm	WORD		V6-LA2...302	°C/°F
V6	V6-LA2	40102	44766.6	RW	Probe 2 minimum alarm	WORD		-58.0...V6-HA2	°C/°F
V6	V6-PAO	40104	44767	RW	Exclude alarm at switch on	WORD		0...10	hours
V6	V6-dAO	40108	44767.2	RW	Exclude alarm after defrost	WORD		0...250	min
V6	V6-OAO	40106	44767.4	RW	Alarm signal delay after closing door	WORD		0...10	hours
V6	V6-tdO	40196	44767.6	RW	Open door disabling time	WORD		0...250	num
V6	V6-tA1	40110	44768	RW	LA1 and HA1 alarm signal delay	WORD		0...250	min
V6	V6-tA2	40112	44768.2	RW	LA2 and HA2 alarm signal delay	WORD		0...250	min
V6	V6-dAt	40028	44768.4	RW	Enable alarm at end of defrost	WORD		0/1	num
V6	V6-EAL	40116	44768.6	RW	External alarm switches off utilities	WORD		0/1/2	num



FOLDER	LABEL	PAR. ADDRESS VALUE	PAR. ADDRESS Vis.	R/W	DESCRIPTION	DATA SIZE	CPL	RANGE	UM
V6	V6-tP	40198	44769	RW	Enable alarm overriding from any key	WORD		0/1	num
V6	V6-Art	40086	44769.2	RW	Alarm activation period supervisor link	WORD		0...250	min*10
V6	V6-dSd	40080	44769.4	RW	Enable light relay from door switch	WORD		0/1	num
V6	V6-dLt	40082	44769.6	RW	Delay disabling light relay	WORD		0...250	min
V6	V6-OFL	40084	44770	RW	Light key always disables light relay	WORD		0/1	num
V6	V6-dOd	40114	44770.2	RW	Door switch turns off utilities	WORD		0...3	num
V6	V6-dOA	40118	44770.4	RW	Action forced by digital input	WORD		0...5	num
V6	V6-PEA	40120	44770.6	RW	DI selected to block/release resources	WORD		0...3	num
V6	V6-dCO	40122	44771	RW	Delay to activate/switch off compressor evap. fan	WORD		0...250	min
V6	V6-dFO	40124	44771.2	RW	Delay to activate/switch off evap. fan	WORD		0...250	min
V6	V6-ASb	40176	44771.4	RW	Key/AUX input/Light active when OFF	WORD		0/1	num
V6	V6-L00	39680	44771.6	RW	Shared probe	WORD		0...6	num
V6	V6-L01	39682	44772	RW	Display value shared	WORD		0/1/2	num
V6	V6-L02	39684	44772.2	RW	Send setpoint value when modified	WORD		0/1	num
V6	V6-L03	39686	44772.4	RW	Send defrost request	WORD		0/1	num
V6	V6-L04	39688	44772.6	RW	End defrost mode	WORD		0/1	num
V6	V6-L05	39690	44773	RW	Synchronization of Stand-By command	WORD		0/1	num
V6	V6-L06	39692	44773.2	RW	Synchronization of light command	WORD		0/1	num
V6	V6-L07	39694	44773.4	RW	Synchronization of reduced setpoint command	WORD		0/1	num
V6	V6-L08	39696	44773.6	RW	Synchronization of AUX command	WORD		0/1	num
V6	V6-L10	40200	44774.2	RW	Wait for end of dependent defrost timeout	WORD		0...250	min
V6	V6-PEn	40076	44774.4	RW	Number of errors allowed	WORD		0...15	num
V6	V6-PEi	40078	44774.6	RW	Error count interval	WORD		1...250	min
V6	V6-dcS	40068	44775	RW	Deep Cooling Setpoint	WORD		-58.0...302	°C/°F
V6	V6-tdc	40070	44775.2	RW	Deep Cooling duration	WORD		0...250	min
V6	V6-dcc	40072	44775.4	RW	Waiting time to start defrost cycle	WORD		0...250	min
V6	V6-ESt	39926	44775.6	RW	Type of Energy Saving	WORD		0...4	num
V6	V6-ESF	40062	44776	RW	Night mode enabled	WORD		0/1	num
V6	V6-Cdt	40064	44776.2	RW	Min. door closed time to activate reduced setpoint	WORD		0...255	min*10
V6	V6-ESo	40066	44776.4	RW	Cumulative door open time	WORD		0...10	num
V6	V6-OS1	39960	44776.6	RW	Offset SP1	WORD		-50.0...50.0	°C/°F
V6	V6-OS2	39962	44777	RW	Offset SP2	WORD		-50.0...50.0	°C/°F
V6	V6-Od1	39964	44777.2	RW	Door energy saving offset 1	WORD		-50.0...50.0	°C/°F
V6	V6-Od2	39966	44777.4	RW	Door energy saving offset 2	WORD		-50.0...50.0	°C/°F
V6	V6-dn1	39942	44777.6	RW	dn1 Differential in energy saving mode 1	WORD		-58.0...302	°C/°F
V6	V6-dn2	39944	44778	RW	dn2 Differential in energy saving mode 2	WORD		-58.0...302	°C/°F
V6	V6-EdH	39914	44778.2	RW	Start time weekday Energy Saving	WORD		0...24	hours
V6	V6-Edn	39916	44778.4	RW	Weekday Energy Saving start time minutes	WORD		0...59	min
V6	V6-Edd	39918	44778.6	RW	Weekday Energy Saving event duration	WORD		1...72	hours
V6	V6-EFH	39920	44779	RW	Weekend/public holiday Energy Saving start time	WORD		0...24	hours
V6	V6-EFn	39922	44779.2	RW	Weekend/public holiday Energy Saving start time minutes	WORD		0...59	min
V6	V6-EFd	39924	44779.4	RW	Weekend/public holiday Energy Saving event duration	WORD		1...72	hours
V6	V6-FH	40126	44779.6	RW	Regulation mode	WORD		0...7	num
V6	V6-FHt	40130	44780	RW	Frame heater period	WORD		1...2500	sec*10
V6	V6-FH0	40132	44780.2	RW	Frame heater setpoint	WORD		-58.0...302	°C/°F
V6	V6-FH1	40134	44780.4	RW	Frame heater offset	WORD		0.0...25.0	°C/°F
V6	V6-FH2	40136	44780.6	RW	Frame heater band	WORD		0.0...25.0	°C/°F
V6	V6-FH3	40138	44781	RW	Min. percentage	WORD		0...100	%
V6	V6-FH4	40140	44781.2	RW	Maximum percentage/Duty Cycle Day	WORD		0...100	%
V6	V6-FH5	40142	44781.4	RW	Maximum percentage/Duty Cycle Night (ES)	WORD		0...100	%
V6	V6-FH6	40144	44781.6	RW	Percentage during defrost	WORD		0...100	%
V6	V6-LOC	40150	44782	RW	Keypad lock	WORD		0/1	num
V6	V6-PS1	40152	44782.2	RW	Password 1	WORD		0...250	num
V6	V6-PS2	40154	44782.4	RW	Password 2	WORD		0...250	num
V6	V6-ndt	40156	44782.6	RW	Display with decimal point	WORD		0/1	num
V6	V6-CA1	39768	44783	RW	Calibration Pb1	WORD		-30.0...30.0	°C/°F





FOLDER	LABEL	PAR. ADDRESS VALUE	PAR. ADDRESS Vis.	R/W	DESCRIPTION	DATA SIZE	CPL	RANGE	UM
V6	V6-CA2	39770	44783.2	RW	Calibration Pb2	WORD		-30.0...30.0	°C/°F
V6	V6-CA3	39772	44783.4	RW	Calibration Pb3	WORD		-30.0...30.0	°C/°F
V6	V6-CA4	39774	44783.6	RW	Calibration Pb4	WORD		-30.0...30.0	°C/°F
V6	V6-CA5	39776	44784	RW	Calibration Pb5	WORD		-30.0...30.0	°C/°F
V6	V6-LdL	40158	44784.6	RW	Minimum value displayable	WORD		-58.0...V6-HdL	°C/°F
V6	V6-HdL	40160	44785	RW	Maximum value displayable	WORD		V6-LdL...302	°C/°F
V6	V6-ddL	40162	44785.2	RW	Block display during defrost	WORD		0/1/2	num
V6	V6-Ldd	40164	44785.4	RW	"ddL" Release Time-Out	WORD		0...250	min
V6	V6-dro	40166	44785.6	RW	°C/°F selection (0=°C, 1=°F)	WORD		0/1	num
V6	V6-ddd	40170	44786.2	RW	Main Display	WORD		0...7	num
V6	V6-ddE	40172	44786.4	RW	Main display on ECHO	WORD		0...7	num
V6	V6-rPH	40074	44786.6	RW	Select HACCP alarm probe	WORD		0...5	num
V6	V6-H00	39700	44787	RW	Type of probe Pb1-Pb2-Pb3-Pb4-Pb5 (0=NTC, 1=PTC, 2=PT1000)	WORD		0/1/2	num
V6	V6-H02	40174	44787.2	RW	Key activation time	WORD		0...250	sec
V6	V6-H08	40178	44787.4	RW	Stand-By mode	WORD		0/1/2	num
V6	V6-H11	39710	44787.6	RW	Configuration input DI1	WORD		-17...17	num
V6	V6-H12	39712	44788	RW	Configuration input DI2	WORD		-17...17	num
V6	V6-H13	39714	44788.2	RW	Configuration input DI3	WORD		-17...17	num
V6	V6-H14	39716	44788.4	RW	Configuration input DI4	WORD		-17...17	num
V6	V6-H15	39718	44788.6	RW	Configuration input DI5	WORD		-17...17	num
V6	V6-H16	39720	44789	RW	Configuration input DI6	WORD		-17...17	num
V6	V6-H17	39722	44789.2	RW	Configuration input DI7	WORD		-17...17	num
V6	V6-H18	39724	44789.4	RW	Configuration input DI8	WORD		-17...17	num
V6	V6-dti	39742	44789.6	RW	Unit of measure for digital inputs 1 and 2	WORD		0...1	num
V6	V6-d11	39726	44790	RW	Activation delay for digital input 1	WORD		0...255	min/sec
V6	V6-d12	39728	44790.2	RW	Activation delay for digital input 2	WORD		0...255	min/sec
V6	V6-d13	39730	44790.4	RW	Activation delay for digital input 3	WORD		0...255	min
V6	V6-d14	39732	44790.6	RW	Activation delay for digital input 4	WORD		0...255	min
V6	V6-d15	39734	44791	RW	Activation delay for digital input 5	WORD		0...255	min
V6	V6-d16	39736	44791.2	RW	Activation delay for digital input 6	WORD		0...255	min
V6	V6-d17	39738	44791.4	RW	Activation delay for digital input 7	WORD		0...255	min
V6	V6-d18	39740	44791.6	RW	Activation delay for digital input 8	WORD		0...255	min
V6	V6-H21	39784	44792	RW	Configuration Relay 1	WORD		0...13	num
V6	V6-H22	39786	44792.2	RW	Configuration Relay 2	WORD		0...13	num
V6	V6-H23	39788	44792.4	RW	Configuration Relay 3	WORD		0...13	num
V6	V6-H24	39790	44792.6	RW	Configuration Relay 4	WORD		0...13	num
V6	V6-H25	39792	44793	RW	Configuration Relay 5	WORD		0...13	num
V6	V6-H26	39794	44793.2	RW	Configuration Relay 6	WORD		0...13	num
V6	V6-H27	39796	44793.4	RW	Configuration Relay 7	WORD		0...13	num
V6	V6-H29	39798	44793.6	RW	Enable buzzer	WORD		0/1	num
V6	V6-H31	40180	44794	RW	Configuration of UP key	WORD		0...8	num
V6	V6-H32	40182	44794.2	RW	Configuration of DOWN key	WORD		0...8	num
V6	V6-H33	40184	44794.4	RW	ESC key configuration	WORD		0...8	num
V6	V6-H41	39744	44795.6	RW	Configuration input Pb1 (0=Disable, 1=DI, 2=H00)	WORD		0/1/2	num
V6	V6-H42	39746	44796	RW	Configuration input Pb2 (0=Disable, 1=DI, 2=H00)	WORD		0/1/2	num
V6	V6-H43	39748	44796.2	RW	Configuration input Pb3 (0=Disable, 1=DI, 2=H00)	WORD		0/1/2	num
V6	V6-H44	39750	44796.4	RW	Configuration input Pb4 (0=Disable, 1=DI, 2=H00)	WORD		0/1/2	num
V6	V6-H45	39752	44796.6	RW	Configuration input Pb5 (0=Disable, 1=DI, 2=H00)	WORD		0/1/2	num
V6	V6-H50	39800	44797.4	RW	Configuration Type of Analogue Output	WORD		0/1	num
V6	V6-H51	39802	44797.6	RW	Regulator associated to analogue output	WORD		0/1	num
V6	V6-H68	39804	44798	RW	Clock Present	WORD		0/1	num
V6	V6-H70	39760	44798.2	RW	Select probe 1 for virtual probe	WORD		0...5	num
V6	V6-H71	39762	44798.4	RW	Select probe 2 for virtual probe	WORD		0...5	num
V6	V6-H72	39764	44798.6	RW	% calculation virtual probe day	WORD		0...100	%
V6	V6-H73	39766	44799	RW	% calculation virtual probe night	WORD		0...100	%
V6	V6-UL	---	44804	RW	Parameter transfer function visibility (Device -> Copy Card)	2 BIT		0...3	num



FOLDER	LABEL	PAR. ADDRESS VALUE	PAR. ADDRESS Vis.	R/W	DESCRIPTION	DATA SIZE	CPL	RANGE	UM
V6	V6-dL	---	44804.2	RW	Parameter transfer function visibility (Copy Card -> Device)	2 BIT		0...3	num
V6	V6-Fr	---	44804.4	RW	Format Copy Card function visibility	2 BIT		0...3	num
<b>APPLICATION 7 PARAMETERS</b>									
	V7-SP1	40702	44928.6	RW	Setpoint	WORD		V7-LS1...V7-HS1	°C/°F
	V7-SP2	40706	44929.2	RW	Thermostat 2 setpoint	WORD		V7-LS2...V7-HS2	°C/°F
V7	V7-rE	40696	44928	RW	Regulation mode	WORD		0...4	num
V7	V7-rP1	40698	44928.2	RW	Regulation probe 1	WORD		0...7	num
V7	V7-rP2	40700	44928.4	RW	Thermostat 2 regulation probe	WORD		0...7	num
V7	V7-dF1	40704	44929	RW	Differential/proportional band	WORD		-58.0...302	°C/°F
V7	V7-dF2	40708	44929.4	RW	Thermostat 2 differential	WORD		-58.0...302	°C/°F
V7	V7-Stt	40714	44929.6	RW	Differential control mode	WORD		0/1	num
V7	V7-HS1	40720	44930	RW	SP1 maximum value	WORD		V7-LS1...V7-HdL	°C/°F
V7	V7-LS1	40722	44930.2	RW	SP1 minimum value	WORD		V7-LdL...V7-HS1	°C/°F
V7	V7-HS2	40724	44930.4	RW	SP2 maximum value	WORD		V7-LS2...V7-HdL	°C/°F
V7	V7-LS2	40726	44930.6	RW	SP2 minimum value	WORD		V7-LdL...V7-HS2	°C/°F
V7	V7-HC1	40716	44931	RW	Thermostat 1 mode	WORD		0/1	num
V7	V7-HC2	40718	44931.2	RW	Thermostat 2 mode	WORD		0/1	num
V7	V7-CC	40756	44931.4	RW	Double power step control	WORD		0/1	num
V7	V7-Cit	40736	44931.6	RW	Minimum compressor ON time	WORD		0...250	min
V7	V7-CAt	40738	44932	RW	Maximum compressor ON time	WORD		0...250	min
V7	V7-Ont	40748	44932.2	RW	ON time for faulty probe	WORD		0...250	min
V7	V7-OFt	40750	44932.4	RW	OFF time for faulty probe	WORD		0...250	min
V7	V7-dOn	40740	44932.6	RW	Switch on delay	WORD		0...250	sec
V7	V7-dOF	40742	44933	RW	Delay after switching off	WORD		0...250	min
V7	V7-dbi	40744	44933.2	RW	Delay between switch-ons	WORD		0...250	min
V7	V7-OdO	40746	44933.4	RW	Output delay from power-on	WORD		0...250	min
V7	V7-CP2	40752	44933.6	RW	Compressor 2 switch-on delay	WORD		0...250	sec
V7	V7-CS2	40754	44934	RW	Power step 2 switch-on delay	WORD		0...250	min
V7	V7-CFP	40914	44934.2	RW	Preventilation time	WORD		0...255	sec
V7	V7-CFd	40916	44934.4	RW	Fan mode	WORD		0/1	num
V7	V7-OF1	40758	44934.6	RW	Forced remote offset	WORD		-50.0...50.0	°C/°F
V7	V7-dP1	40760	44935	RW	Selection defrost probe 1	WORD		0...7	num
V7	V7-dP2	40762	44935.2	RW	Selection defrost probe 2	WORD		0...7	num
V7	V7-dtY	40768	44935.4	RW	Defrost mode	WORD		0...4	num
V7	V7-dFt	40764	44935.6	RW	Defrost activation mode with two probes	WORD		0/1/2	num
V7	V7-dit	40770	44936	RW	Interval between defrost cycles	WORD		0...250	hours
V7	V7-dt1	40776	44936.2	RW	Unit of measurement for defrost interval	WORD		0/1/2	num
V7	V7-dt2	40778	44936.4	RW	Unit of measure for defrost duration	WORD		0/1/2	num
V7	V7-dCt	40766	44936.6	RW	Defrost interval count mode	WORD		0...5	num
V7	V7-dOH	40780	44937	RW	Defrost interval count mode	WORD		0...250	min
V7	V7-dE1	40772	44937.2	RW	Evaporator 1 defrost time-out	WORD		1...250	min
V7	V7-dE2	40774	44937.4	RW	Evaporator 2 defrost time-out	WORD		1...250	min
V7	V7-dS1	40784	44937.6	RW	Probe 1 end of defrost temperature	WORD		-58.0...302	°C/°F
V7	V7-dS2	40786	44938	RW	Probe 2 end of defrost temperature	WORD		-58.0...302	°C/°F
V7	V7-dSS	40782	44938.2	RW	Start defrost temperature threshold	WORD		-58.0...302	°C/°F
V7	V7-dPO	40788	44938.4	RW	Request defrost activation from power on	WORD		0/1	num
V7	V7-tcd	40790	44938.6	RW	Min. compressor ON or OFF time before defrost	WORD		-60...60	min
V7	V7-ndE	40792	44939	RW	Minimum defrost time (for hot gas only)	WORD		0...250	min
V7	V7-PdC	40794	44939.2	RW	Hot gas extraction time at defrost end	WORD		0...250	min
V7	V7-tPd	40798	44939.4	RW	Pump down time before defrost startup	WORD		0...255	min
V7	V7-dPH	40676	44939.6	RW	Start time for periodical defrost	WORD		0...24	hours
V7	V7-dPn	40678	44940	RW	Start time minutes for periodical defrost	WORD		0...59	min
V7	V7-dPd	40680	44940.2	RW	Periodical defrost interval duration	WORD		1...7	Day
V7	V7-Fd1	40574	44940.4	RW	Weekend/public holiday 1	WORD		0...7	num
V7	V7-Fd2	40576	44940.6	RW	Weekend/public holiday 2	WORD		0...7	num
V7	V7-Edt	40578	44941	RW	Customized duration and temperature for each event	WORD		0/1	num



FOLDER	LABEL	PAR. ADDRESS VALUE	PAR. ADDRESS Vis.	R/W	DESCRIPTION	DATA SIZE	CPL	RANGE	UM
V7	V7-d1H	40580	44941.2	RW	Start time weekday defrost 1	WORD		0...24	hours
V7	V7-d1n	40582	44941.4	RW	Start time minutes weekday defrost 1	WORD		0...59	min
V7	V7-d1t	40584	44941.6	RW	Weekday defrost 1 duration	WORD		0...250	min
V7	V7-d1S	40586	44942	RW	End of weekday defrost 1 temperature	WORD		-58.0...302	°C/°F
V7	V7-d2H	40588	44942.2	RW	Start time weekday defrost 2	WORD		V7-d1H...24	hours
V7	V7-d2n	40590	44942.4	RW	Start time minutes weekday defrost 2	WORD		0...59	min
V7	V7-d2t	40592	44942.6	RW	Weekday defrost 2 duration	WORD		0...250	min
V7	V7-d2S	40594	44943	RW	End of weekday defrost 2 temperature	WORD		-58.0...302	°C/°F
V7	V7-d3H	40596	44943.2	RW	Start time weekday defrost 3	WORD		V7-d2H...24	hours
V7	V7-d3n	40598	44943.4	RW	Start time minutes weekday defrost 3	WORD		0...59	min
V7	V7-d3t	40600	44943.6	RW	Weekday defrost 3 duration	WORD		0...250	min
V7	V7-d3S	40602	44944	RW	End of weekday defrost 3 temperature	WORD		-58.0...302	°C/°F
V7	V7-d4H	40604	44944.2	RW	Start time weekday defrost 4	WORD		V7-d3H...24	hours
V7	V7-d4n	40606	44944.4	RW	Start time minutes weekday defrost 4	WORD		0...59	min
V7	V7-d4t	40608	44944.6	RW	Weekday defrost 4 duration	WORD		0...250	min
V7	V7-d4S	40610	44945	RW	End of weekday defrost 4 temperature	WORD		-58.0...302	°C/°F
V7	V7-d5H	40612	44945.2	RW	Start time weekday defrost 5	WORD		V7-d4H...24	hours
V7	V7-d5n	40614	44945.4	RW	Start time minutes weekday defrost 5	WORD		0...59	min
V7	V7-d5t	40616	44945.6	RW	Weekday defrost 5 duration	WORD		0...250	min
V7	V7-d5S	40618	44946	RW	End of weekday defrost 5 temperature	WORD		-58.0...302	°C/°F
V7	V7-d6H	40620	44946.2	RW	Start time weekday defrost 6	WORD		V7-d5H...24	hours
V7	V7-d6n	40622	44946.4	RW	Start time minutes weekday defrost 6	WORD		0...59	min
V7	V7-d6t	40624	44946.6	RW	Weekday defrost 6 duration	WORD		0...250	min
V7	V7-d6S	40626	44947	RW	End of weekday defrost 6 temperature	WORD		-58.0...302	°C/°F
V7	V7-F1H	40628	44947.2	RW	Start time weekend/public holiday defrost 1	WORD		0...24	hours
V7	V7-F1n	40630	44947.4	RW	Weekend/public holiday defrost 1 start time minutes	WORD		0...59	min
V7	V7-F1t	40632	44947.6	RW	Weekend/public holiday defrost 1 duration	WORD		0...250	min
V7	V7-F1S	40634	44948	RW	End of weekend/public holiday defrost 1 temperature	WORD		-58.0...302	°C/°F
V7	V7-F2H	40636	44948.2	RW	Start time weekend/public holiday defrost 2	WORD		V7-F1H...24	hours
V7	V7-F2n	40638	44948.4	RW	Weekend/public holiday defrost 2 start time minutes	WORD		0...59	min
V7	V7-F2t	40640	44948.6	RW	Weekend/public holiday defrost 2 duration	WORD		0...250	min
V7	V7-F2S	40642	44949	RW	End of weekend/public holiday defrost 1 temperature	WORD		-58.0...302	°C/°F
V7	V7-F3H	40644	44949.2	RW	Start time weekend/public holiday defrost 3	WORD		V7-F2H...24	hours
V7	V7-F3n	40646	44949.4	RW	Weekend/public holiday defrost 3 start time minutes	WORD		0...59	min
V7	V7-F3t	40648	44949.6	RW	Weekend/public holiday defrost 3 duration	WORD		0...250	min
V7	V7-F3S	40650	44950	RW	End of weekend/public holiday defrost 1 temperature	WORD		-58.0...302	°C/°F
V7	V7-F4H	40652	44950.2	RW	Start time weekend/public holiday defrost 4	WORD		V7-F3H...24	hours
V7	V7-F4n	40654	44950.4	RW	Weekend/public holiday defrost 4 start time minutes	WORD		0...59	min
V7	V7-F4t	40656	44950.6	RW	Weekend/public holiday defrost 4 duration	WORD		0...250	min
V7	V7-F4S	40658	44951	RW	End of weekend/public holiday defrost 1 temperature	WORD		-58.0...302	°C/°F
V7	V7-F5H	40660	44951.2	RW	Start time weekend/public holiday defrost 5	WORD		V7-F4H...24	hours
V7	V7-F5n	40662	44951.4	RW	Weekend/public holiday defrost 5 start time minutes	WORD		0...59	min
V7	V7-F5t	40664	44951.6	RW	Weekend/public holiday defrost 5 duration	WORD		0...250	min
V7	V7-F5S	40666	44952	RW	End of weekend/public holiday defrost 1 temperature	WORD		-58.0...302	°C/°F
V7	V7-F6H	40668	44952.2	RW	Start time weekend/public holiday defrost 6	WORD		V7-F5H...24	hours
V7	V7-F6n	40670	44952.4	RW	Weekend/public holiday defrost 6 start time minutes	WORD		0...59	min
V7	V7-F6t	40672	44952.6	RW	Weekend/public holiday defrost 6 duration	WORD		0...250	min
V7	V7-F6S	40674	44953	RW	End of weekend/public holiday defrost 6 temperature	WORD		-58.0...302	°C/°F
V7	V7-FP1	40800	44953.2	RW	Evaporator fan probe in normal mode	WORD		0...7	num
V7	V7-FP2	40802	44953.4	RW	Evaporator fan probe during defrost stage	WORD		0...7	num
V7	V7-FPt	40804	44953.6	RW	FSt parameter mode	WORD		0/1	num
V7	V7-FSt	40806	44954	RW	Block fan temperature	WORD		-58.0...302	°C/°F
V7	V7-FAd	40808	44954.2	RW	Fan differential	WORD		0.1...25.0	°C/°F
V7	V7-Fdt	40810	44954.4	RW	Fan activation delay after compressor start	WORD		0...250	min
V7	V7-dt	40820	44954.6	RW	Dripping time	WORD		0...250	min
V7	V7-dFd	40816	44955	RW	Evaporator fan mode during defrost	WORD		0/1	num



FOLDER	LABEL	PAR. ADDRESS VALUE	PAR. ADDRESS Vis.	R/W	DESCRIPTION	DATA SIZE	CPL	RANGE	UM
V7	V7-FCO	40814	44955.2	RW	Evaporator fan mode	WORD		0...3	num
V7	V7-FdC	40812	44955.6	RW	Fan switch off delay after compressor stop	WORD		0...250	min
V7	V7-FOn	40822	44956	RW	Fan ON time in Duty Cycle	WORD		0...250	min
V7	V7-FOF	40824	44956.2	RW	Fan OFF time in Duty Cycle	WORD		0...250	min
V7	V7-Fnn	40826	44956.4	RW	Duty cycle on time during night mode	WORD		0...250	min
V7	V7-FnF	40828	44956.6	RW	Duty cycle off time during night mode	WORD		0...250	min
V7	V7-rA1	40856	44957	RW	Temperature alarm probe 1 selection	WORD		0...6	num
V7	V7-rA2	40858	44957.2	RW	Temperature alarm probe 2 selection	WORD		0...6	num
V7	V7-Att	40860	44957.4	RW	Parameter HAL and LAL mode	WORD		0/1	num
V7	V7-AFd	40862	44957.6	RW	Alarm setpoint differential	WORD		0.1...25.0	°C/°F
V7	V7-HA1	40864	44958	RW	Probe 1 maximum alarm	WORD		V7-LA1...302	°C/°F
V7	V7-LA1	40866	44958.2	RW	Probe 1 minimum alarm	WORD		-58.0...V7-HA1	°C/°F
V7	V7-HA2	40868	44958.4	RW	Probe 2 maximum alarm	WORD		V7-LA2...302	°C/°F
V7	V7-LA2	40870	44958.6	RW	Probe 2 minimum alarm	WORD		-58.0...V7-HA2	°C/°F
V7	V7-PAO	40872	44959	RW	Exclude alarm at switch on	WORD		0...10	hours
V7	V7-dAO	40876	44959.2	RW	Exclude alarm after defrost	WORD		0...250	min
V7	V7-OAO	40874	44959.4	RW	Alarm signal delay after closing door	WORD		0...10	hours
V7	V7-tdO	40964	44959.6	RW	Open door disabling time	WORD		0...250	num
V7	V7-tA1	40878	44960	RW	LA1 and HA1 alarm signal delay	WORD		0...250	min
V7	V7-tA2	40880	44960.2	RW	LA2 and HA2 alarm signal delay	WORD		0...250	min
V7	V7-dAt	40796	44960.4	RW	Enable alarm at end of defrost	WORD		0/1	num
V7	V7-EAL	40884	44960.6	RW	External alarm switches off utilities	WORD		0/1/2	num
V7	V7-tP	40966	44961	RW	Enable alarm overriding from any key	WORD		0/1	num
V7	V7-Art	40854	44961.2	RW	Alarm activation period supervisor link	WORD		0...250	min*10
V7	V7-dSd	40848	44961.4	RW	Enable light relay from door switch	WORD		0/1	num
V7	V7-dLt	40850	44961.6	RW	Delay disabling light relay	WORD		0...250	min
V7	V7-OFL	40852	44962	RW	Light key always disables light relay	WORD		0/1	num
V7	V7-dOd	40882	44962.2	RW	Door switch turns off utilities	WORD		0...3	num
V7	V7-dOA	40886	44962.4	RW	Action forced by digital input	WORD		0...5	num
V7	V7-PEA	40888	44962.6	RW	DI selected to block/release resources	WORD		0...3	num
V7	V7-dCO	40890	44963	RW	Delay to activate/switch off compressor evap. fan	WORD		0...250	min
V7	V7-dFO	40892	44963.2	RW	Delay to activate/switch off evap. fan	WORD		0...250	min
V7	V7-ASb	40944	44963.4	RW	Key/AUX input/Light active when OFF	WORD		0/1	num
V7	V7-L00	40448	44963.6	RW	Shared probe	WORD		0...6	num
V7	V7-L01	40450	44964	RW	Display value shared	WORD		0/1/2	num
V7	V7-L02	40452	44964.2	RW	Send setpoint value when modified	WORD		0/1	num
V7	V7-L03	40454	44964.4	RW	Send defrost request	WORD		0/1	num
V7	V7-L04	40456	44964.6	RW	End defrost mode	WORD		0/1	num
V7	V7-L05	40458	44965	RW	Synchronization of Stand-By command	WORD		0/1	num
V7	V7-L06	40460	44965.2	RW	Synchronization of light command	WORD		0/1	num
V7	V7-L07	40462	44965.4	RW	Synchronization of reduced setpoint command	WORD		0/1	num
V7	V7-L08	40464	44965.6	RW	Synchronization of AUX command	WORD		0/1	num
V7	V7-L10	40968	44966.2	RW	Wait for end of dependent defrost timeout	WORD		0...250	min
V7	V7-PEn	40844	44966.4	RW	Number of errors allowed	WORD		0...15	num
V7	V7-PEi	40846	44966.6	RW	Error count interval	WORD		1...250	min
V7	V7-dcS	40836	44967	RW	Deep Cooling Setpoint	WORD		-58.0...302	°C/°F
V7	V7-tdc	40838	44967.2	RW	Deep Cooling duration	WORD		0...250	min
V7	V7-dcc	40840	44967.4	RW	Waiting time to start defrost cycle	WORD		0...250	min
V7	V7-ESt	40694	44967.6	RW	Type of Energy Saving	WORD		0...4	num
V7	V7-ESF	40830	44968	RW	Night mode enabled	WORD		0/1	num
V7	V7-Cdt	40832	44968.2	RW	Min. door closed time to activate reduced setpoint	WORD		0...255	min*10
V7	V7-ESo	40834	44968.4	RW	Cumulative door open time	WORD		0...10	num
V7	V7-OS1	40728	44968.6	RW	Offset SP1	WORD		-50.0...50.0	°C/°F
V7	V7-OS2	40730	44969	RW	Offset SP2	WORD		-50.0...50.0	°C/°F
V7	V7-Od1	40732	44969.2	RW	Door energy saving offset 1	WORD		-50.0...50.0	°C/°F
V7	V7-Od2	40734	44969.4	RW	Door energy saving offset 2	WORD		-50.0...50.0	°C/°F



FOLDER	LABEL	PAR. ADDRESS VALUE	PAR. ADDRESS Vis.	R/W	DESCRIPTION	DATA SIZE	CPL	RANGE	UM
V7	V7-dn1	40710	44969.6	RW	dn1 Differential in energy saving mode 1	WORD		-58.0...302	°C/°F
V7	V7-dn2	40712	44970	RW	dn2 Differential in energy saving mode 2	WORD		-58.0...302	°C/°F
V7	V7-EdH	40682	44970.2	RW	Start time weekday Energy Saving	WORD		0...24	hours
V7	V7-Edn	40684	44970.4	RW	Weekday Energy Saving start time minutes	WORD		0...59	min
V7	V7-Edd	40686	44970.6	RW	Weekday Energy Saving event duration	WORD		1...72	hours
V7	V7-EFH	40688	44971	RW	Weekend/public holiday Energy Saving start time	WORD		0...24	hours
V7	V7-EFn	40690	44971.2	RW	Weekend/public holiday Energy Saving start time minutes	WORD		0...59	min
V7	V7-EFd	40692	44971.4	RW	Weekend/public holiday Energy Saving event duration	WORD		1...72	hours
V7	V7-FH	40894	44971.6	RW	Regulation mode	WORD		0...7	num
V7	V7-FHt	40898	44972	RW	Frame heater period	WORD		1...2500	sec*10
V7	V7-FH0	40900	44972.2	RW	Frame heater setpoint	WORD		-58.0...302	°C/°F
V7	V7-FH1	40902	44972.4	RW	Frame heater offset	WORD		0.0...25.0	°C/°F
V7	V7-FH2	40904	44972.6	RW	Frame heater band	WORD		0.0...25.0	°C/°F
V7	V7-FH3	40906	44973	RW	Min. percentage	WORD		0...100	%
V7	V7-FH4	40908	44973.2	RW	Maximum percentage/Duty Cycle Day	WORD		0...100	%
V7	V7-FH5	40910	44973.4	RW	Maximum percentage/Duty Cycle Night (ES)	WORD		0...100	%
V7	V7-FH6	40912	44973.6	RW	Percentage during defrost	WORD		0...100	%
V7	V7-LOC	40918	44974	RW	Keypad lock	WORD		0/1	num
V7	V7-PS1	40920	44974.2	RW	Password 1	WORD		0...250	num
V7	V7-PS2	40922	44974.4	RW	Password 2	WORD		0...250	num
V7	V7-ndt	40924	44974.6	RW	Display with decimal point	WORD		0/1	num
V7	V7-CA1	40536	44975	RW	Calibration Pb1	WORD		-30.0...30.0	°C/°F
V7	V7-CA2	40538	44975.2	RW	Calibration Pb2	WORD		-30.0...30.0	°C/°F
V7	V7-CA3	40540	44975.4	RW	Calibration Pb3	WORD		-30.0...30.0	°C/°F
V7	V7-CA4	40542	44975.6	RW	Calibration Pb4	WORD		-30.0...30.0	°C/°F
V7	V7-CA5	40544	44976	RW	Calibration Pb5	WORD		-30.0...30.0	°C/°F
V7	V7-LdL	40926	44976.6	RW	Minimum value displayable	WORD		-58.0...V7-HdL	°C/°F
V7	V7-HdL	40928	44977	RW	Maximum value displayable	WORD		V7-LdL...302	°C/°F
V7	V7-ddL	40930	44977.2	RW	Block display during defrost	WORD		0/1/2	num
V7	V7-Ldd	40932	44977.4	RW	"ddL" Release Time-Out	WORD		0...250	min
V7	V7-dro	40934	44977.6	RW	°C/°F selection (0=°C, 1=°F)	WORD		0/1	num
V7	V7-ddd	40938	44978.2	RW	Main Display	WORD		0...7	num
V7	V7-ddE	40940	44978.4	RW	Main display on ECHO	WORD		0...7	num
V7	V7-rPH	40842	44978.6	RW	Select HACCP alarm probe	WORD		0...5	num
V7	V7-H00	40468	44979	RW	Type of probe Pb1-Pb2-Pb3-Pb4-Pb5 (0=NTC, 1=PTC, 2=PT1000)	WORD		0/1/2	num
V7	V7-H02	40942	44979.2	RW	Key activation time	WORD		0...250	sec
V7	V7-H08	40946	44979.4	RW	Stand-By mode	WORD		0/1/2	num
V7	V7-H11	40478	44979.6	RW	Configuration input DI1	WORD		-17...17	num
V7	V7-H12	40480	44980	RW	Configuration input DI2	WORD		-17...17	num
V7	V7-H13	40482	44980.2	RW	Configuration input DI3	WORD		-17...17	num
V7	V7-H14	40484	44980.4	RW	Configuration input DI4	WORD		-17...17	num
V7	V7-H15	40486	44980.6	RW	Configuration input DI5	WORD		-17...17	num
V7	V7-H16	40488	44981	RW	Configuration input DI6	WORD		-17...17	num
V7	V7-H17	40490	44981.2	RW	Configuration input DI7	WORD		-17...17	num
V7	V7-H18	40492	44981.4	RW	Configuration input DI8	WORD		-17...17	num
V7	V7-dti	40510	44981.6	RW	Unit of measure for digital inputs 1 and 2	WORD		0/1	num
V7	V7-d11	40494	44982	RW	Activation delay for digital input 1	WORD		0...255	min/sec
V7	V7-d12	40496	44982.2	RW	Activation delay for digital input 2	WORD		0...255	min/sec
V7	V7-d13	40498	44982.4	RW	Activation delay for digital input 3	WORD		0...255	min
V7	V7-d14	40500	44982.6	RW	Activation delay for digital input 4	WORD		0...255	min
V7	V7-d15	40502	44983	RW	Activation delay for digital input 5	WORD		0...255	min
V7	V7-d16	40504	44983.2	RW	Activation delay for digital input 6	WORD		0...255	min
V7	V7-d17	40506	44983.4	RW	Activation delay for digital input 7	WORD		0...255	min
V7	V7-d18	40508	44983.6	RW	Activation delay for digital input 8	WORD		0...255	min
V7	V7-H21	40552	44984	RW	Configuration Relay 1	WORD		0...13	num
V7	V7-H22	40554	44984.2	RW	Configuration Relay 2	WORD		0...13	num



FOLDER	LABEL	PAR. ADDRESS VALUE	PAR. ADDRESS Vis.	R/W	DESCRIPTION	DATA SIZE	CPL	RANGE	UM
V7	V7-H23	40556	44984.4	RW	Configuration Relay 3	WORD		0...13	num
V7	V7-H24	40558	44984.6	RW	Configuration Relay 4	WORD		0...13	num
V7	V7-H25	40560	44985	RW	Configuration Relay 5	WORD		0...13	num
V7	V7-H26	40562	44985.2	RW	Configuration Relay 6	WORD		0...13	num
V7	V7-H27	40564	44985.4	RW	Configuration Relay 7	WORD		0...13	num
V7	V7-H29	40566	44985.6	RW	Enable buzzer	WORD		0/1	num
V7	V7-H31	40948	44986	RW	Configuration of UP key	WORD		0...8	num
V7	V7-H32	40950	44986.2	RW	Configuration of DOWN key	WORD		0...8	num
V7	V7-H33	40952	44986.4	RW	ESC key configuration	WORD		0...8	num
V7	V7-H41	40512	44987.6	RW	Configuration input Pb1 (0=Disable, 1=DI, 2=H00)	WORD		0/1/2	num
V7	V7-H42	40514	44988	RW	Configuration input Pb2 (0=Disable, 1=DI, 2=H00)	WORD		0/1/2	num
V7	V7-H43	40516	44988.2	RW	Configuration input Pb3 (0=Disable, 1=DI, 2=H00)	WORD		0/1/2	num
V7	V7-H44	40518	44988.4	RW	Configuration input Pb4 (0=Disable, 1=DI, 2=H00)	WORD		0/1/2	num
V7	V7-H45	40520	44988.6	RW	Configuration input Pb5 (0=Disable, 1=DI, 2=H00)	WORD		0/1/2	num
V7	V7-H50	40568	44989.4	RW	Configuration Type of Analogue Output	WORD		0/1	num
V7	V7-H51	40570	44989.6	RW	Regulator associated to analogue output	WORD		0/1	num
V7	V7-H68	40572	44990	RW	Clock Present	WORD		0/1	num
V7	V7-H70	40528	44990.2	RW	Select probe 1 for virtual probe	WORD		0...5	num
V7	V7-H71	40530	44990.4	RW	Select probe 2 for virtual probe	WORD		0...5	num
V7	V7-H72	40532	44990.6	RW	% calculation virtual probe day	WORD		0...100	%
V7	V7-H73	40534	44991	RW	% calculation virtual probe night	WORD		0...100	%
V7	V7-UL	---	44996	RW	Parameter transfer function visibility (Device -> Copy Card)	2 BIT		0...3	num
V7	V7-dL	---	44996.2	RW	Parameter transfer function visibility (Copy Card -> Device)	2 BIT		0...3	num
V7	V7-Fr	---	44996.4	RW	Format Copy Card function visibility	2 BIT		0...3	num
APPLICATION 8 PARAMETERS									
	V8-SP1	41470	45120.6	RW	Setpoint	WORD		V8-LS1...V8-HS1	°C/°F
	V8-SP2	41474	45121.2	RW	Thermostat 2 setpoint	WORD		V8-LS2...V8-HS2	°C/°F
V8	V8-rE	41464	45120	RW	Regulation mode	WORD		0...4	num
V8	V8-rP1	41466	45120.2	RW	Regulation probe 1	WORD		0...7	num
V8	V8-rP2	41468	45120.4	RW	Thermostat 2 regulation probe	WORD		0...7	num
V8	V8-dF1	41472	45121	RW	Differential/proportional band	WORD		-58.0...302	°C/°F
V8	V8-dF2	41476	45121.4	RW	Thermostat 2 differential	WORD		-58.0...302	°C/°F
V8	V8-Stt	41482	45121.6	RW	Differential control mode	WORD		0/1	num
V8	V8-HS1	41488	45122	RW	SP1 maximum value	WORD		V8-LS1...V8-HdL	°C/°F
V8	V8-LS1	41490	45122.2	RW	SP1 minimum value	WORD		V8-LdL...V8-HS1	°C/°F
V8	V8-HS2	41492	45122.4	RW	SP2 maximum value	WORD		V8-LS2...V8-HdL	°C/°F
V8	V8-LS2	41494	45122.6	RW	SP2 minimum value	WORD		V8-LdL...V8-HS2	°C/°F
V8	V8-HC1	41484	45123	RW	Thermostat 1 mode	WORD		0/1	num
V8	V8-HC2	41486	45123.2	RW	Thermostat 2 mode	WORD		0/1	num
V8	V8-CC	41524	45123.4	RW	Double power step control	WORD		0/1	num
V8	V8-Cit	41504	45123.6	RW	Minimum compressor ON time	WORD		0...250	min
V8	V8-CAt	41506	45124	RW	Maximum compressor ON time	WORD		0...250	min
V8	V8-OnT	41516	45124.2	RW	ON time for faulty probe	WORD		0...250	min
V8	V8-OFt	41518	45124.4	RW	OFF time for faulty probe	WORD		0...250	min
V8	V8-dOn	41508	45124.6	RW	Switch on delay	WORD		0...250	sec
V8	V8-dOF	41510	45125	RW	Delay after switching off	WORD		0...250	min
V8	V8-dbi	41512	45125.2	RW	Delay between switch-ons	WORD		0...250	min
V8	V8-OdO	41514	45125.4	RW	Output delay from power-on	WORD		0...250	min
V8	V8-CP2	41520	45125.6	RW	Compressor 2 switch-on delay	WORD		0...250	sec
V8	V8-CS2	41522	45126	RW	Power step 2 switch-on delay	WORD		0...250	min
V8	V8-CFP	41682	45126.2	RW	Preventilation time	WORD		0...255	sec
V8	V8-CFd	41684	45126.4	RW	Fan mode	WORD		0/1	num
V8	V8-OF1	41526	45126.6	RW	Forced remote offset	WORD		-50.0...50.0	°C/°F
V8	V8-dP1	41528	45127	RW	Selection defrost probe 1	WORD		0...7	num
V8	V8-dP2	41530	45127.2	RW	Selection defrost probe 2	WORD		0...7	num
V8	V8-dtY	41536	45127.4	RW	Defrost mode	WORD		0...4	num



FOLDER	LABEL	PAR. ADDRESS VALUE	PAR. ADDRESS Vis.	R/W	DESCRIPTION	DATA SIZE	CPL	RANGE	UM
V8	V8-dFt	41532	45127.6	RW	Defrost activation mode with two probes	WORD		0/1/2	num
V8	V8-dit	41538	45128	RW	Interval between defrost cycles	WORD		0...250	hours
V8	V8-dt1	41544	45128.2	RW	Unit of measurement for defrost interval	WORD		0/1/2	num
V8	V8-dt2	41546	45128.4	RW	Unit of measure for defrost duration	WORD		0/1/2	num
V8	V8-dCt	41534	45128.6	RW	Defrost interval count mode	WORD		0...5	num
V8	V8-dOH	41548	45129	RW	Defrost interval count mode	WORD		0...250	min
V8	V8-dE1	41540	45129.2	RW	Evaporator 1 defrost time-out	WORD		1...250	min
V8	V8-dE2	41542	45129.4	RW	Evaporator 2 defrost time-out	WORD		1...250	min
V8	V8-dS1	41552	45129.6	RW	Probe 1 end of defrost temperature	WORD		-58.0...302	°C/°F
V8	V8-dS2	41554	45130	RW	Probe 2 end of defrost temperature	WORD		-58.0...302	°C/°F
V8	V8-dSS	41550	45130.2	RW	Start defrost temperature threshold	WORD		-58.0...302	°C/°F
V8	V8-dPO	41556	45130.4	RW	Request defrost activation from power on	WORD		0/1	num
V8	V8-tcd	41558	45130.6	RW	Min. compressor ON or OFF time before defrost	WORD		-60...60	min
V8	V8-ndE	41560	45131	RW	Minimum defrost time (for hot gas only)	WORD		0...250	min
V8	V8-PdC	41562	45131.2	RW	Hot gas extraction time at defrost end	WORD		0...250	min
V8	V8-tPd	41566	45131.4	RW	Pump down time before defrost startup	WORD		0...255	min
V8	V8-dPH	41444	45131.6	RW	Start time for periodical defrost	WORD		0...24	hours
V8	V8-dPn	41446	45132	RW	Start time minutes for periodical defrost	WORD		0...59	min
V8	V8-dPd	41448	45132.2	RW	Periodical defrost interval duration	WORD		1...7	Day
V8	V8-Fd1	41342	45132.4	RW	Weekend/public holiday 1	WORD		0...7	num
V8	V8-Fd2	41344	45132.6	RW	Weekend/public holiday 2	WORD		0...7	num
V8	V8-Edt	41346	45133	RW	Customized duration and temperature for each event	WORD		0/1	num
V8	V8-d1H	41348	45133.2	RW	Start time weekday defrost 1	WORD		0...24	hours
V8	V8-d1n	41350	45133.4	RW	Start time minutes weekday defrost 1	WORD		0...59	min
V8	V8-d1t	41352	45133.6	RW	Weekday defrost 1 duration	WORD		0...250	min
V8	V8-d1S	41354	45134	RW	End of weekday defrost 1 temperature	WORD		-58.0...302	°C/°F
V8	V8-d2H	41356	45134.2	RW	Start time weekday defrost 2	WORD		V8-d1H...24	hours
V8	V8-d2n	41358	45134.4	RW	Start time minutes weekday defrost 2	WORD		0...59	min
V8	V8-d2t	41360	45134.6	RW	Weekday defrost 2 duration	WORD		0...250	min
V8	V8-d2S	41362	45135	RW	End of weekday defrost 2 temperature	WORD		-58.0...302	°C/°F
V8	V8-d3H	41364	45135.2	RW	Start time weekday defrost 3	WORD		V8-d2H...24	hours
V8	V8-d3n	41366	45135.4	RW	Start time minutes weekday defrost 3	WORD		0...59	min
V8	V8-d3t	41368	45135.6	RW	Weekday defrost 3 duration	WORD		0...250	min
V8	V8-d3S	41370	45136	RW	End of weekday defrost 3 temperature	WORD		-58.0...302	°C/°F
V8	V8-d4H	41372	45136.2	RW	Start time weekday defrost 4	WORD		V8-d3H...24	hours
V8	V8-d4n	41374	45136.4	RW	Start time minutes weekday defrost 4	WORD		0...59	min
V8	V8-d4t	41376	45136.6	RW	Weekday defrost 4 duration	WORD		0...250	min
V8	V8-d4S	41378	45137	RW	End of weekday defrost 4 temperature	WORD		-58.0...302	°C/°F
V8	V8-d5H	41380	45137.2	RW	Start time weekday defrost 5	WORD		V8-d4H...24	hours
V8	V8-d5n	41382	45137.4	RW	Start time minutes weekday defrost 5	WORD		0...59	min
V8	V8-d5t	41384	45137.6	RW	Weekday defrost 5 duration	WORD		0...250	min
V8	V8-d5S	41386	45138	RW	End of weekday defrost 5 temperature	WORD		-58.0...302	°C/°F
V8	V8-d6H	41388	45138.2	RW	Start time weekday defrost 6	WORD		V8-d5H...24	hours
V8	V8-d6n	41390	45138.4	RW	Start time minutes weekday defrost 6	WORD		0...59	min
V8	V8-d6t	41392	45138.6	RW	Weekday defrost 6 duration	WORD		0...250	min
V8	V8-d6S	41394	45139	RW	End of weekday defrost 6 temperature	WORD		-58.0...302	°C/°F
V8	V8-F1H	41396	45139.2	RW	Start time weekend/public holiday defrost 1	WORD		0...24	hours
V8	V8-F1n	41398	45139.4	RW	Weekend/public holiday defrost 1 start time minutes	WORD		0...59	min
V8	V8-F1t	41400	45139.6	RW	Weekend/public holiday defrost 1 duration	WORD		0...250	min
V8	V8-F1S	41402	45140	RW	End of weekend/public holiday defrost 1 temperature	WORD		-58.0...302	°C/°F
V8	V8-F2H	41404	45140.2	RW	Start time weekend/public holiday defrost 2	WORD		V8-F1H...24	hours
V8	V8-F2n	41406	45140.4	RW	Weekend/public holiday defrost 2 start time minutes	WORD		0...59	min
V8	V8-F2t	41408	45140.6	RW	Weekend/public holiday defrost 2 duration	WORD		0...250	min
V8	V8-F2S	41410	45141	RW	End of weekend/public holiday defrost 1 temperature	WORD		-58.0...302	°C/°F
V8	V8-F3H	41412	45141.2	RW	Start time weekend/public holiday defrost 3	WORD		V8-F2H...24	hours
V8	V8-F3n	41414	45141.4	RW	Weekend/public holiday defrost 3 start time minutes	WORD		0...59	min



FOLDER	LABEL	PAR. ADDRESS VALUE	PAR. ADDRESS Vis.	R/W	DESCRIPTION	DATA SIZE	CPL	RANGE	UM
V8	V8-F3t	41416	45141.6	RW	Weekend/public holiday defrost 3 duration	WORD		0...250	min
V8	V8-F3S	41418	45142	RW	End of weekend/public holiday defrost 1 temperature	WORD		-58.0...302	°C/°F
V8	V8-F4H	41420	45142.2	RW	Start time weekend/public holiday defrost 4	WORD		V8-F3H...24	hours
V8	V8-F4n	41422	45142.4	RW	Weekend/public holiday defrost 4 start time minutes	WORD		0...59	min
V8	V8-F4t	41424	45142.6	RW	Weekend/public holiday defrost 4 duration	WORD		0...250	min
V8	V8-F4S	41426	45143	RW	End of weekend/public holiday defrost 1 temperature	WORD		-58.0...302	°C/°F
V8	V8-F5H	41428	45143.2	RW	Start time weekend/public holiday defrost 5	WORD		F4H...24	hours
V8	V8-F5n	41430	45143.4	RW	Weekend/public holiday defrost 5 start time minutes	WORD		0...59	min
V8	V8-F5t	41432	45143.6	RW	Weekend/public holiday defrost 5 duration	WORD		0...250	min
V8	V8-F5S	41434	45144	RW	End of weekend/public holiday defrost 1 temperature	WORD		-58.0...302	°C/°F
V8	V8-F6H	41436	45144.2	RW	Start time weekend/public holiday defrost 6	WORD		F5H...24	hours
V8	V8-F6n	41438	45144.4	RW	Weekend/public holiday defrost 6 start time minutes	WORD		0...59	min
V8	V8-F6t	41440	45144.6	RW	Weekend/public holiday defrost 6 duration	WORD		0...250	min
V8	V8-F6S	41442	45145	RW	End of weekend/public holiday defrost 6 temperature	WORD		-58.0...302	°C/°F
V8	V8-FP1	41568	45145.2	RW	Evaporator fan probe in normal mode	WORD		0...7	num
V8	V8-FP2	41570	45145.4	RW	Evaporator fan probe during defrost stage	WORD		0...7	num
V8	V8-FPt	41572	45145.6	RW	FSt parameter mode	WORD		0/1	num
V8	V8-FSt	41574	45146	RW	Block fan temperature	WORD		-58.0...302	°C/°F
V8	V8-FAd	41576	45146.2	RW	Fan differential	WORD		0.1...25.0	°C/°F
V8	V8-Fdt	41578	45146.4	RW	Fan activation delay after compressor start	WORD		0...250	min
V8	V8-dt	41588	45146.6	RW	Dripping time	WORD		0...250	min
V8	V8-dFd	41584	45147	RW	Evaporator fan mode during defrost	WORD		0/1	num
V8	V8-FCO	41582	45147.2	RW	Evaporator fan mode	WORD		0...3	num
V8	V8-FdC	41580	45147.6	RW	Fan switch off delay after compressor stop	WORD		0...250	min
V8	V8-FOn	41590	45148	RW	Fan ON time in Duty Cycle	WORD		0...250	min
V8	V8-FOF	41592	45148.2	RW	Fan OFF time in Duty Cycle	WORD		0...250	min
V8	V8-Fnn	41594	45148.4	RW	Duty cycle on time during night mode	WORD		0...250	min
V8	V8-FnF	41596	45148.6	RW	Duty cycle off time during night mode	WORD		0...250	min
V8	V8-rA1	41624	45149	RW	Temperature alarm probe 1 selection	WORD		0...6	num
V8	V8-rA2	41626	45149.2	RW	Temperature alarm probe 2 selection	WORD		0...6	num
V8	V8-Att	41628	45149.4	RW	Parameter HAL and LAL mode	WORD		0/1	num
V8	V8-AFd	41630	45149.6	RW	Alarm setpoint differential	WORD		0.1...25.0	°C/°F
V8	V8-HA1	41632	45150	RW	Probe 1 maximum alarm	WORD		V8-LA1...302	°C/°F
V8	V8-LA1	41634	45150.2	RW	Probe 1 minimum alarm	WORD		-58.0...V8-HA1	°C/°F
V8	V8-HA2	41636	45150.4	RW	Probe 2 maximum alarm	WORD		V8-LA2...302	°C/°F
V8	V8-LA2	41638	45150.6	RW	Probe 2 minimum alarm	WORD		-58.0...V8-HA2	°C/°F
V8	V8-PAO	41640	45151	RW	Exclude alarm at switch on	WORD		0...10	hours
V8	V8-dAO	41644	45151.2	RW	Exclude alarm after defrost	WORD		0...250	min
V8	V8-OAO	41642	45151.4	RW	Alarm signal delay after closing door	WORD		0...10	hours
V8	V8-tdO	41732	45151.6	RW	Open door disabling time	WORD		0...250	num
V8	V8-tA1	41646	45152	RW	LA1 and HA1 alarm signal delay	WORD		0...250	min
V8	V8-tA2	41648	45152.2	RW	LA2 and HA2 alarm signal delay	WORD		0...250	min
V8	V8-dAt	41564	45152.4	RW	Enable alarm at end of defrost	WORD		0/1	num
V8	V8-EAL	41652	45152.6	RW	External alarm switches off utilities	WORD		0/1/2	num
V8	V8-tP	41734	45153	RW	Enable alarm overriding from any key	WORD		0/1	num
V8	V8-Art	41622	45153.2	RW	Alarm activation period supervisor link	WORD		0...250	min*10
V8	V8-dSd	41616	45153.4	RW	Enable light relay from door switch	WORD		0/1	num
V8	V8-dLt	41618	45153.6	RW	Delay disabling light relay	WORD		0...250	min
V8	V8-OFL	41620	45154	RW	Light key always disables light relay	WORD		0/1	num
V8	V8-dOd	41650	45154.2	RW	Door switch turns off utilities	WORD		0...3	num
V8	V8-dOA	41654	45154.4	RW	Action forced by digital input	WORD		0...5	num
V8	V8-PEA	41656	45154.6	RW	DI selected to block/release resources	WORD		0...3	num
V8	V8-dCO	41658	45155	RW	Delay to activate/switch off compressor evap. fan	WORD		0...250	min
V8	V8-dFO	41660	45155.2	RW	Delay to activate/switch off evap. fan	WORD		0...250	min
V8	V8-ASb	41712	45155.4	RW	Key/AUX input/Light active when OFF	WORD		0/1	num





FOLDER	LABEL	PAR. ADDRESS VALUE	PAR. ADDRESS Vis.	R/W	DESCRIPTION	DATA SIZE	CPL	RANGE	UM
V8	V8-L00	41216	45155.6	RW	Shared probe	WORD		0...6	num
V8	V8-L01	41218	45156	RW	Display value shared	WORD		0/1/2	num
V8	V8-L02	41220	45156.2	RW	Send setpoint value when modified	WORD		0/1	num
V8	V8-L03	41222	45156.4	RW	Send defrost request	WORD		0/1	num
V8	V8-L04	41224	45156.6	RW	End defrost mode	WORD		0/1	num
V8	V8-L05	41226	45157	RW	Synchronization of Stand-By command	WORD		0/1	num
V8	V8-L06	41228	45157.2	RW	Synchronization of light command	WORD		0/1	num
V8	V8-L07	41230	45157.4	RW	Synchronization of reduced setpoint command	WORD		0/1	num
V8	V8-L08	41232	45157.6	RW	Synchronization of AUX command	WORD		0/1	num
V8	V8-L10	41736	45158.2	RW	Wait for end of dependent defrost timeout	WORD		0...250	min
V8	V8-PEn	41612	45158.4	RW	Number of errors allowed	WORD		0...15	num
V8	V8-PEi	41614	45158.6	RW	Error count interval	WORD		1...250	min
V8	V8-dcS	41604	45159	RW	Deep Cooling Setpoint	WORD		-58.0...302	°C/°F
V8	V8-tdc	41606	45159.2	RW	Deep Cooling duration	WORD		0...250	min
V8	V8-dcc	41608	45159.4	RW	Waiting time to start defrost cycle	WORD		0...250	min
V8	V8-ESt	41462	45159.6	RW	Type of Energy Saving	WORD		0...4	num
V8	V8-ESF	41598	45160	RW	Night mode enabled	WORD		0/1	num
V8	V8-Cdt	41600	45160.2	RW	Min. door closed time to activate reduced setpoint	WORD		0...255	min*10
V8	V8-ESo	41602	45160.4	RW	Cumulative door open time	WORD		0...10	num
V8	V8-OS1	41496	45160.6	RW	Offset SP1	WORD		-50.0...50.0	°C/°F
V8	V8-OS2	41498	45161	RW	Offset SP2	WORD		-50.0...50.0	°C/°F
V8	V8-Od1	41500	45161.2	RW	Door energy saving offset 1	WORD		-50.0...50.0	°C/°F
V8	V8-Od2	41502	45161.4	RW	Door energy saving offset 2	WORD		-50.0...50.0	°C/°F
V8	V8-dn1	41478	45161.6	RW	dn1 Differential in energy saving mode 1	WORD		-58.0...302	°C/°F
V8	V8-dn2	41480	45162	RW	dn2 Differential in energy saving mode 2	WORD		-58.0...302	°C/°F
V8	V8-EdH	41450	45162.2	RW	Start time weekday Energy Saving	WORD		0...24	hours
V8	V8-Edn	41452	45162.4	RW	Weekday Energy Saving start time minutes	WORD		0...59	min
V8	V8-Edd	41454	45162.6	RW	Weekday Energy Saving event duration	WORD		1...72	hours
V8	V8-EFH	41456	45163	RW	Weekend/public holiday Energy Saving start time	WORD		0...24	hours
V8	V8-EFn	41458	45163.2	RW	Weekend/public holiday Energy Saving start time minutes	WORD		0...59	min
V8	V8-EFd	41460	45163.4	RW	Weekend/public holiday Energy Saving event duration	WORD		1...72	hours
V8	V8-FH	41662	45163.6	RW	Regulation mode	WORD		0...7	num
V8	V8-FHt	41666	45164	RW	Frame heater period	WORD		1...2500	sec*10
V8	V8-FH0	41668	45164.2	RW	Frame heater setpoint	WORD		-58.0...302	°C/°F
V8	V8-FH1	41670	45164.4	RW	Frame heater offset	WORD		0.0...25.0	°C/°F
V8	V8-FH2	41672	45164.6	RW	Frame heater band	WORD		0.0...25.0	°C/°F
V8	V8-FH3	41674	45165	RW	Min. percentage	WORD		0...100	%
V8	V8-FH4	41676	45165.2	RW	Maximum percentage/Duty Cycle Day	WORD		0...100	%
V8	V8-FH5	41678	45165.4	RW	Maximum percentage/Duty Cycle Night (ES)	WORD		0...100	%
V8	V8-FH6	41680	45165.6	RW	Percentage during defrost	WORD		0...100	%
V8	V8-LOC	41686	45166	RW	Keypad lock	WORD		0/1	num
V8	V8-PS1	41688	45166.2	RW	Password 1	WORD		0...250	num
V8	V8-PS2	41690	45166.4	RW	Password 2	WORD		0...250	num
V8	V8-ndt	41692	45166.6	RW	Display with decimal point	WORD		0/1	num
V8	V8-CA1	41304	45167	RW	Calibration Pb1	WORD		-30.0...30.0	°C/°F
V8	V8-CA2	41306	45167.2	RW	Calibration Pb2	WORD		-30.0...30.0	°C/°F
V8	V8-CA3	41308	45167.4	RW	Calibration Pb3	WORD		-30.0...30.0	°C/°F
V8	V8-CA4	41310	45167.6	RW	Calibration Pb4	WORD		-30.0...30.0	°C/°F
V8	V8-CA5	41312	45168	RW	Calibration Pb5	WORD		-30.0...30.0	°C/°F
V8	V8-LdL	41694	45168.6	RW	Minimum value displayable	WORD		-58.0...V8-HdL	°C/°F
V8	V8-HdL	41696	45169	RW	Maximum value displayable	WORD		V8-LdL...302	°C/°F
V8	V8-ddL	41698	45169.2	RW	Block display during defrost	WORD		0/1/2	num
V8	V8-Ldd	41700	45169.4	RW	"ddL" Release Time-Out	WORD		0...250	min
V8	V8-dro	41702	45169.6	RW	°C/°F selection (0=°C, 1=°F)	WORD		0/1	num
V8	V8-ddd	41706	45170.2	RW	Main Display	WORD		0...7	num



FOLDER	LABEL	PAR. ADDRESS VALUE	PAR. ADDRESS Vis.	R/W	DESCRIPTION	DATA SIZE	CPL	RANGE	UM
V8	V8-ddE	41708	45170.4	RW	Main display on ECHO	WORD		0..7	num
V8	V8-rPH	41610	45170.6	RW	Select HACCP alarm probe	WORD		0..5	num
V8	V8-H00	41236	45171	RW	Type of probe Pb1-Pb2-Pb3-Pb4-Pb5 (0=NTC, 1=PTC, 2=PT1000)	WORD		0/1/2	num
V8	V8-H02	41710	45171.2	RW	Key activation time	WORD		0...250	sec
V8	V8-H08	41714	45171.4	RW	Stand-By mode	WORD		0..2	num
V8	V8-H11	41246	45171.6	RW	Configuration input DI1	WORD		-17...17	num
V8	V8-H12	41248	45172	RW	Configuration input DI2	WORD		-17...17	num
V8	V8-H13	41250	45172.2	RW	Configuration input DI3	WORD		-17...17	num
V8	V8-H14	41252	45172.4	RW	Configuration input DI4	WORD		-17...17	num
V8	V8-H15	41254	45172.6	RW	Configuration input DI5	WORD		-17...17	num
V8	V8-H16	41256	45173	RW	Configuration input DI6	WORD		-17...17	num
V8	V8-H17	41258	45173.2	RW	Configuration input DI7	WORD		-17...17	num
V8	V8-H18	41260	45173.4	RW	Configuration input DI8	WORD		-17...17	num
V8	V8-dti	41278	45173.6	RW	Unit of measure for digital inputs 1 and 2	WORD		0/1	num
V8	V8-d11	41262	45174	RW	Activation delay for digital input 1	WORD		0...255	min/sec
V8	V8-d12	41264	45174.2	RW	Activation delay for digital input 2	WORD		0...255	min/sec
V8	V8-d13	41266	45174.4	RW	Activation delay for digital input 3	WORD		0...255	min
V8	V8-d14	41268	45174.6	RW	Activation delay for digital input 4	WORD		0...255	min
V8	V8-d15	41270	45175	RW	Activation delay for digital input 5	WORD		0...255	min
V8	V8-d16	41272	45175.2	RW	Activation delay for digital input 6	WORD		0...255	min
V8	V8-d17	41274	45175.4	RW	Activation delay for digital input 7	WORD		0...255	min
V8	V8-d18	41276	45175.6	RW	Activation delay for digital input 8	WORD		0...255	min
V8	V8-H21	41320	45176	RW	Configuration Relay 1	WORD		0..13	num
V8	V8-H22	41322	45176.2	RW	Configuration Relay 2	WORD		0..13	num
V8	V8-H23	41324	45176.4	RW	Configuration Relay 3	WORD		0..13	num
V8	V8-H24	41326	45176.6	RW	Configuration Relay 4	WORD		0..13	num
V8	V8-H25	41328	45177	RW	Configuration Relay 5	WORD		0..13	num
V8	V8-H26	41330	45177.2	RW	Configuration Relay 6	WORD		0..13	num
V8	V8-H27	41332	45177.4	RW	Configuration Relay 7	WORD		0..13	num
V8	V8-H29	41334	45177.6	RW	Enable buzzer	WORD		0/1	num
V8	V8-H31	41716	45178	RW	Configuration of UP key	WORD		0..8	num
V8	V8-H32	41718	45178.2	RW	Configuration of DOWN key	WORD		0..8	num
V8	V8-H33	41720	45178.4	RW	ESC key configuration	WORD		0..8	num
V8	V8-H41	41280	45179.6	RW	Configuration input Pb1 (0=Disable, 1=DI, 2=H00)	WORD		0/1/2	num
V8	V8-H42	41282	45180	RW	Configuration input Pb2 (0=Disable, 1=DI, 2=H00)	WORD		0/1/2	num
V8	V8-H43	41284	45180.2	RW	Configuration input Pb3 (0=Disable, 1=DI, 2=H00)	WORD		0/1/2	num
V8	V8-H44	41286	45180.4	RW	Configuration input Pb4 (0=Disable, 1=DI, 2=H00)	WORD		0/1/2	num
V8	V8-H45	41288	45180.6	RW	Configuration input Pb5 (0=Disable, 1=DI, 2=H00)	WORD		0/1/2	num
V8	V8-H50	41336	45181.4	RW	Configuration Type of Analogue Output	WORD		0/1	num
V8	V8-H51	41338	45181.6	RW	Regulator associated to analogue output	WORD		0/1	num
V8	V8-H68	41340	45182	RW	Clock Present	WORD		0/1	num
V8	V8-H70	41296	45182.2	RW	Select probe 1 for virtual probe	WORD		0..5	num
V8	V8-H71	41298	45182.4	RW	Select probe 2 for virtual probe	WORD		0..5	num
V8	V8-H72	41300	45182.6	RW	% calculation virtual probe day	WORD		0...100	%
V8	V8-H73	41302	45183	RW	% calculation virtual probe night	WORD		0...100	%
V8	V8-UL	---	45188	RW	Parameter transfer function visibility (Device -> Copy Card)	2 BIT		0..3	num
V8	V8-dL	---	45188.2	RW	Parameter transfer function visibility (Copy Card -> Device)	2 BIT		0..3	num
V8	V8-Fr	---	45188.4	RW	Format Copy Card function visibility	2 BIT		0..3	num



## 8.2.2 - FOLDER VISIBILITY TABLE

LABEL	MODBUS ADDRESS	R/W	DESCRIPTION	DATA SIZE	RANGE	Address by Application								UM
						AP1	AP2	AP3	AP4	AP5	AP6	AP7	AP8	
vis_CP	43583.4	RW	CP (Compressor) folder visibility	2 BIT	0 ... 3	43839.4	44031.4	44223.4	44415.4	44607.4	44799.4	44991.4	45183.4	num
vis_dEF	43583.6	RW	dEF (Defrost) folder visibility	2 BIT	0 ... 3	43839.6	44031.6	44223.6	44415.6	44607.6	44799.6	44991.6	45183.6	num
vis_FAn	43584	RW	FAn (Fans) folder visibility	2 BIT	0 ... 3	43840	44032	44224	44416	44608	44800	44992	45184	num
vis_AL	43584.2	RW	AL (Alarms) folder visibility	2 BIT	0 ... 3	43840.2	44032.2	44224.2	44416.2	44608.2	44800.2	44992.2	45184.2	num
vis_Lit	43584.4	RW	Lit (Lights & Digital Inputs) folder visibility	2 BIT	0 ... 3	43840.4	44032.4	44224.4	44416.4	44608.4	44800.4	44992.4	45184.4	num
vis_Lin	43584.6	RW	Visibility Lin folder (LINK <sup>2</sup> )	2 BIT	0 ... 3	43840.6	44032.6	44224.6	44416.6	44608.6	44800.6	44992.6	45184.6	num
vis_PrE	43585	RW	PrE (Pressure switch) folder visibility	2 BIT	0 ... 3	43841	44033	44225	44417	44609	44801	44993	45185	num
vis_dEC	43585.4	RW	Visibility folder dEC (Deep cooling)	2 BIT	0 ... 3	43841.4	44033.4	44225.4	44417.4	44609.4	44801.4	44993.4	45185.4	num
vis_EnS	43585.6	RW	Visibility folder EnS (Energy Saving)	2 BIT	0 ... 3	43841.6	44033.6	44225.6	44417.6	44609.6	44801.6	44993.6	45185.6	num
vis_FrH	43586	RW	Visibility folder FrH (Frame Heater)	2 BIT	0 ... 3	43842	44034	44226	44418	44610	44802	44994	45186	num
vis_Add	43586.2	RW	Add (Communication) folder visibility	2 BIT	0 ... 3	43842.2	44034.2	44226.2	44418.2	44610.2	44802.2	44994.2	45186.2	num
vis_diS	43586.4	RW	diS (Display) folder visibility	2 BIT	0 ... 3	43842.4	44034.4	44226.4	44418.4	44610.4	44802.4	44994.4	45186.4	num
vis_HCP	43586.6	RW	HCP (HACCP) folder visibility	2 BIT	0 ... 3	43842.6	44034.6	44226.6	44418.6	44610.6	44802.6	44994.6	45186.6	num
vis_CnF	43587	RW	CnF (Configuration) folder visibility	2 BIT	0 ... 3	43843	44035	44227	44419	44611	44803	44995	45187	num
vis_EEO	43587.2	RW	Visibility folder EEO (Electronic Valve)	2 BIT	0 ... 3	43843.2	44035.2	44227.2	44419.2	44611.2	44803.2	44995.2	45187.2	num
vis_FPr	43587.4	RW	FPr (Copy Card) folder visibility	2 BIT	0 ... 3	43843.4	44035.4	44227.4	44419.4	44611.4	44803.4	44995.4	45187.4	num
vis_FnC	53587.6	RW	FnC (Functions) folder visibility	2 BIT	0 ... 3	43843.6	44035.6	44227.6	44419.6	44611.6	44803.6	44995.6	45187.6	num

## 8.2.3 - TABELLA CLIENT

**N.B.:** Reading Modbus command: 03 (0x03) and Writing Modbus command: 16 (0x10)

LABEL	ADDRESS	R/W	DESCRIPTION	DATA SIZE	RANGE	UM
A1	513	R	Regulation probe 1	WORD	-67.0...320	°C/°F
A2	514	R	Regulation probe 2	WORD	-67.0...320	°C/°F
A3	515	R	Temperature Alarm Probe 1	WORD	-67.0...320	°C/°F
A4	516	R	Temperature Alarm Probe 2	WORD	-67.0...320	°C/°F
A5	517	R	Defrost probe 1	WORD	-67.0...320	°C/°F
A6	518	R	Defrost probe 2	WORD	-67.0...320	°C/°F
A7	519	R	Evaporator fan probe	WORD	-67.0...320	°C/°F
A8	520	R	Frame heater probe	WORD	-67.0...320	°C/°F
A9	521	R	evaporator valve pressure	WORD	-67.0...320	bar/Psi
A10	522	R	valve overheating temperature	WORD	-67.0...320	°C/°F
A11	523	R	HACCP probe	WORD	-67.0...320	°C/°F
SP1	524	R	regulation setpoint value 1	WORD	-67.0...320	°C/°F
SP2	525	R	regulation setpoint value 2	WORD	-67.0...320	°C/°F
OH1	526	R	Overheating Value	WORD	-67.0...320	°C/°F
BKP	542	R	Backup Saturation Probe {0}	WORD	-67.0...320	°C/°F
rDP	543	R	Dew point value	WORD	-67.0...320	°C/°F
dis	527	R	Display value	WORD	-67.0...320	°C/°F
vr1	528	R	Probe x for virtual probe calculation	WORD	-67.0...320	°C/°F
vr2	529	R	Probe x for virtual probe calculation	WORD	-67.0...320	°C/°F
EEV	1025	R	valve opening percentage	WORD	100.0	%
FrH	1026	R	Frame heater output	WORD	100.0	%
EA1	513	R	Probe error AI1	WORD	0...1	flag
EA2	514	R	Probe error AI2	WORD	0...1	flag
EA3	515	R	Probe error AI3	WORD	0...1	flag
EA4	516	R	Probe error AI4	WORD	0...1	flag
EA5	517	R	Probe error AI5	WORD	0...1	flag
EA6	518	R	Probe error AI6	WORD	0...1	flag
EA7	519	R	Probe error AI7	WORD	0...1	flag
EA8	520	R	Probe error AI8	WORD	0...1	flag
EA9	521	R	Probe error AI9	WORD	0...1	flag
EA10	522	R	Probe error AI10	WORD	0...1	flag
EA11	523	R	Probe error AI11	WORD	0...1	flag
EOH1	526	R	Probe error OH1	WORD	0...1	flag
EBKP	542	R	Probe error BKP	WORD	0...1	flag



LABEL	ADDRESS	R/W	DESCRIPTION	DATA SIZE	RANGE	UM
ErDP	543	R	Probe error rDP	WORD	0...1	flag
Edis	527	R	Probe error dis	WORD	0...1	flag
Evr1	528	R	Probe error vr1	WORD	0...1	flag
Evr2	529	R	Probe error vr2	WORD	0...1	flag
E1	1537	R	Probe error AI1	WORD	0...1	flag
E2	1538	R	Probe error AI2	WORD	0...1	flag
E3	1539	R	Probe error AI3	WORD	0...1	flag
E4	1540	R	Probe error AI4	WORD	0...1	flag
E5	1541	R	Probe error AI5	WORD	0...1	flag
E6	1542	R	Probe error AI6	WORD	0...1	flag
E7	1543	R	Probe error AI7	WORD	0...1	flag
AL1	1544	R	Low temperature alarm 1	WORD	0...1	flag
AH1	1545	R	High temperature alarm 1	WORD	0...1	flag
AL2	1546	R	Low temperature alarm 2	WORD	0...1	flag
AH2	1547	R	High temperature alarm 2	WORD	0...1	flag
OPd	1548	R	Door open alarm	WORD	0...1	flag
EA	1549	R	External alarm digital input	WORD	0...1	flag
Prr	1550	R	Preheating input regulator alarm	WORD	0...1	flag
Ad2	1551	R	Defrost timeout	WORD	0...1	flag
nPA	1552	R	Pressure switch alarm	WORD	0...1	flag
LPA	1554	R	Low pressure switch alarm	WORD	0...1	flag
HPA	1556	R	High pressure switch alarm	WORD	0...1	flag
E10	1558	R	RTA battery low alarm	WORD	0...1	flag
AtS	1559	R	Communication test alarm	WORD	0...1	flag
H0t	1560	R	Valve MOP alarm	WORD	0...1	flag
tHA	1561	R	Valve output max alarm	WORD	0...1	flag
OFF	5121	R	stand-by	WORD	0...1	flag
C1	5122	R	Compressor State 1	WORD	0...1	flag
C2	5123	R	Compressor State 2	WORD	0...1	flag
Def	5124	R	Defrost State	WORD	0...1	flag
FEv	5125	R	Evaporator Fan State	WORD	0...1	flag
ALM	5127	R	Alarm State	WORD	0...1	flag
AUX	5128	R	Auxiliary State	WORD	0...1	flag
Lig	5129	R	Light State	WORD	0...1	flag
DP	5130	R	Deep Cooling	WORD	0...1	flag
FH	5131	R	Frame Heaters	WORD	0...1	flag
SeR	5132	R	Reduced Set Regulator	WORD	0...1	flag
ES	5133	R	Energy saving...	WORD	0...1	flag
do	5134	R	Door open	WORD	0...1	flag
dyS	5135	R	Active dynamic setpoint	WORD	0...1	flag
gDI	5136	R	Generic input state	WORD	0...1	flag
nAU	2561	RW	Auxiliary On	WORD	0...1	flag
oAU	2562	RW	Auxiliary Off	WORD	0...1	flag
nSB	2563	RW	Device On	WORD	0...1	flag
oSB	2564	RW	Device Off	WORD	0...1	flag
nES	2565	RW	Activation Energy Saving function	WORD	0...1	flag
oNS	2566	RW	Disable Energy Saving function	WORD	0...1	flag
nSR	2567	RW	Activation Economy	WORD	0...1	flag
oSR	2568	RW	Disable Economy	WORD	0...1	flag
nLI	2569	RW	Lights On	WORD	0...1	flag
oLI	2570	RW	Lights Off	WORD	0...1	flag
nBT	2571	RW	Lock Keypad	WORD	0...1	flag
oBT	2572	RW	Unlock Keypad	WORD	0...1	flag
nDM	2573	RW	Activate Manual Defrost	WORD	0...1	flag
oPV	2574	RW	Open valve command	WORD	0...1	flag
nPV	2575	RW	Close valve command	WORD	0...1	flag
nOS	2576	RW	Activate force setpoint offset	WORD	0...1	flag
oOS	2577	RW	Disable force setpoint offset	WORD	0...1	flag
dEC	2578	RW	Enable Deep Cooling	WORD	0...1	flag
ClkUp	2579	R	Reset Clock	WORD	0...1	flag



### 9.1 - ELECTRICAL CONNECTIONS

**Important! Make sure the appliance is switched off before working on the electrical connections.**

The device has a terminal board with disconnectable terminals for the connection of electrical cables of max. diameter 2.5 mm<sup>2</sup> (only one conductor per terminal for power connections): see the label on the device for details of terminal ratings. Do not exceed the maximum permitted current; for higher loads, use a contactor with sufficient power capacity. Make sure that the power supply is of the correct voltage for the device.

Probes have no connection polarity and can be extended using a normal bipolar cable (note that the extension of the probes influences the instrument's electromagnetic compatibility -EMC: take great care with the wiring). Probe cables, power supply cables and the TTL serial cable should be routed separately from the mains power cables.

### 9.2 - DISCLAIMER

This document is the exclusive property of ELIWELL CONTROLS SRL and may not be reproduced or circulated without the express permission of ELIWELL CONTROLS.

While all possible care has been taken to ensure the accuracy of this document, ELIWELL CONTROLS SRL cannot accept liability for any damage resulting from its use. The same applies to any person or company involved in preparing and editing this document. ELIWELL CONTROLS SRL reserves the right to make aesthetic or functional changes at any time without notice.

### 9.3 - RESPONSIBILITIES AND RESIDUAL RISKS

ELIWELL CONTROLS SRL is not liable for damage caused by:

- installation/use other than expressly specified and, in particular, in conflict with the safety prescriptions set down in regulations and/or specified in this document
- use on panels that do not provide adequate protection against electric shocks, water or dust in the adopted mounting conditions;
- use on panels allowing access to dangerous parts without having to use tools;
- tampering with and/or modification of the product;
- installation/use on panels that do not comply with statutory laws and regulations.

### 9.4 - CONDITIONS OF USE

#### Permitted use

For safety reasons, the instrument must be installed and used according to the instructions provided. In particular, parts carrying dangerous voltages must not be accessible under normal operating conditions. The device must be adequately protected from water and dust with regard to the application, and must only be accessible using tools (with the exception of the front panel). The device is suitable for use in household refrigeration appliances and/or similar equipment and has been tested for safety aspects in accordance with harmonized European reference standards.

#### Improper use

Any use other than that expressly permitted is prohibited. The relays provided are of a functional type and can be subject to failure: any protection devices required by product standards, or suggested by common sense for obvious safety requirements, must be installed externally to the controller.



## LVD - POWER SUPPLY CONTROL



**IMPORTANT:** this function is OPTIONAL and is available only on request. Check whether the instrument is equipped with it.

### Description

When the voltage either falls below the minimum threshold (set in parameter **SPL**) or rises above the maximum threshold (set in parameter **SPH**), one, two or all of the outputs will be disabled, depending on the setting of parameter **SoU**. When the voltage either rises above the value **SPL+dFL** or falls below the value **SPH-dFL**, the outputs will be re-enabled, taking into account any delay settings. If **SPL/SPH = 0** the high/low voltage control is disabled. When a low or high voltage alarm is present in the alarms folder ALr the label **LoP** or **HiP** will appear.

### Regulation diagrams

The regulation diagrams are as follows:

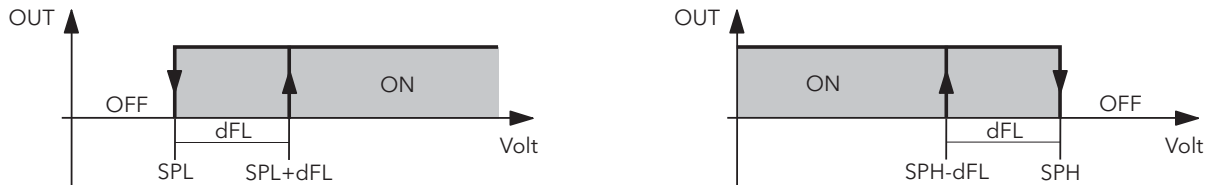

The following is an example of compressor operation on the basis of supply voltage trend:

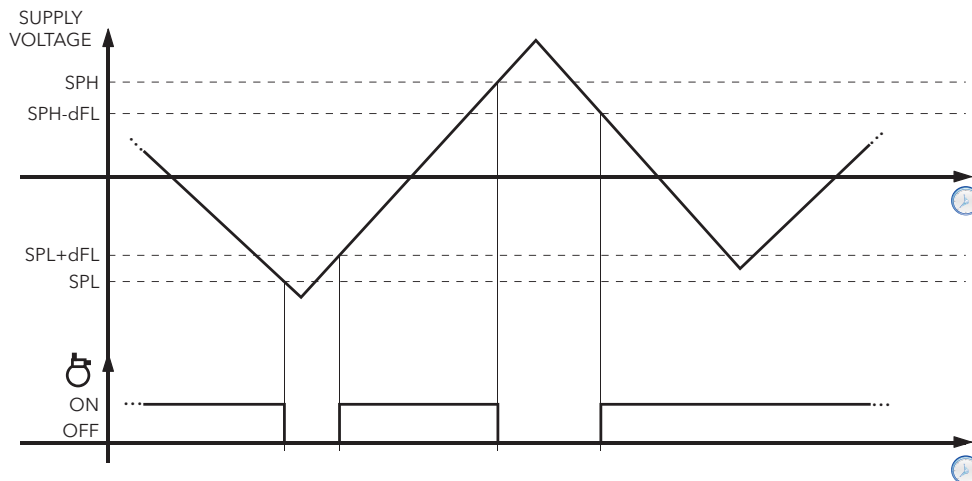

### Signalling

Label	Fault	Cause	Effects	Remedy
<b>HiP</b>	HIGH voltage alarm	voltage value reading at analogue input higher than value of <b>SPH</b> .	<ul style="list-style-type: none"> <li>Recording of label <b>HiP</b> in folder ALr</li> <li>Alarm icon permanently on</li> <li>Regulation lock based on value of SoU</li> </ul>	<ul style="list-style-type: none"> <li>Wait until value read by the analogue input returns below (SPH-dFL).</li> </ul>
<b>LoP</b>	LOW voltage alarm	voltage value reading at analogue input lower than value of <b>SPL</b> .	<ul style="list-style-type: none"> <li>Recording of label <b>HiP</b> in folder ALr</li> <li>Alarm icon permanently on</li> <li>Regulation lock based on value of SoU</li> </ul>	<ul style="list-style-type: none"> <li>Wait until value read by the analogue input returns above (SPL-dFL).</li> </ul>

### User parameters

The parameters that manage the control of the supply voltage are:

PAR.	DESCRIPTION	UM	RANGE	AP1	AP2	AP3	AP4	AP5	AP6	AP7	AP8
<b>SPH</b>	Supply voltage maximum threshold. <b>0</b> = function excluded.	Volts	0...250	(Parameter not present in vectors)							
<b>SPL</b>	Supply voltage minimum threshold. <b>0</b> = function excluded.	Volts	0...300	(Parameter not present in vectors)							
<b>dFL</b>	Activation differential <b>0</b> = function excluded.	Volts	0.1...25.0	(Parameter not present in vectors)							
<b>SoU</b>	Selection of output to be disabled. <b>See table below.</b>	num	0...127	(Parameter not present in vectors)							



Depending on the value of the parameter **SoU**, the protection situation on the outputs is as follows:

SoU	OUT1	OUT2	OUT3	OUT4	OUT5	OUT6	Open Collector
0							
1	Output OFF						
2		Output OFF					
3	Output OFF	Output OFF					
4			Output OFF				
5	Output OFF		Output OFF				
6		Output OFF	Output OFF				
7	Output OFF	Output OFF	Output OFF				
8				Output OFF			
9	Output OFF			Output OFF			
10		Output OFF		Output OFF			
11	Output OFF	Output OFF		Output OFF			
12			Output OFF	Output OFF			
13	Output OFF		Output OFF	Output OFF			
14		Output OFF	Output OFF	Output OFF			
15	Output OFF	Output OFF	Output OFF	Output OFF			
16					Output OFF		
17	Output OFF				Output OFF		
18		Output OFF			Output OFF		
19	Output OFF	Output OFF			Output OFF		
20			Output OFF		Output OFF		
21	Output OFF		Output OFF		Output OFF		
22		Output OFF	Output OFF		Output OFF		
23	Output OFF	Output OFF	Output OFF		Output OFF		
24				Output OFF	Output OFF		
25	Output OFF			Output OFF	Output OFF		
26		Output OFF		Output OFF	Output OFF		
27	Output OFF	Output OFF		Output OFF	Output OFF		
28			Output OFF	Output OFF	Output OFF		
29	Output OFF		Output OFF	Output OFF	Output OFF		
30		Output OFF	Output OFF	Output OFF	Output OFF		
31	Output OFF	Output OFF	Output OFF	Output OFF	Output OFF		
32						Output OFF	
33	Output OFF					Output OFF	
34		Output OFF				Output OFF	
35	Output OFF	Output OFF				Output OFF	
36			Output OFF			Output OFF	
37	Output OFF		Output OFF			Output OFF	
38		Output OFF	Output OFF			Output OFF	
39	Output OFF	Output OFF	Output OFF			Output OFF	
40				Output OFF		Output OFF	
41	Output OFF			Output OFF		Output OFF	
42		Output OFF		Output OFF		Output OFF	
43	Output OFF	Output OFF		Output OFF		Output OFF	
44			Output OFF	Output OFF		Output OFF	
45	Output OFF		Output OFF	Output OFF		Output OFF	
46		Output OFF	Output OFF	Output OFF		Output OFF	
47	Output OFF	Output OFF	Output OFF	Output OFF		Output OFF	
48					Output OFF	Output OFF	



SoU	OUT1	OUT2	OUT3	OUT4	OUT5	OUT6	Open Collector
49	Output OFF				Output OFF	Output OFF	
50		Output OFF			Output OFF	Output OFF	
51	Output OFF	Output OFF			Output OFF	Output OFF	
52			Output OFF		Output OFF	Output OFF	
53	Output OFF		Output OFF		Output OFF	Output OFF	
54		Output OFF	Output OFF		Output OFF	Output OFF	
55	Output OFF	Output OFF	Output OFF		Output OFF	Output OFF	
56				Output OFF	Output OFF	Output OFF	
57	Output OFF			Output OFF	Output OFF	Output OFF	
58		Output OFF		Output OFF	Output OFF	Output OFF	
59	Output OFF	Output OFF		Output OFF	Output OFF	Output OFF	
60			Output OFF	Output OFF	Output OFF	Output OFF	
61	Output OFF		Output OFF	Output OFF	Output OFF	Output OFF	
62		Output OFF	Output OFF	Output OFF	Output OFF	Output OFF	
63	Output OFF	Output OFF	Output OFF	Output OFF	Output OFF	Output OFF	
64							Output OFF
65	Output OFF						Output OFF
66		Output OFF					Output OFF
67	Output OFF	Output OFF					Output OFF
68			Output OFF				Output OFF
69	Output OFF		Output OFF				Output OFF
70		Output OFF	Output OFF				Output OFF
71	Output OFF	Output OFF	Output OFF				Output OFF
72				Output OFF			Output OFF
73	Output OFF			Output OFF			Output OFF
74		Output OFF		Output OFF			Output OFF
75	Output OFF	Output OFF		Output OFF			Output OFF
76			Output OFF	Output OFF			Output OFF
77	Output OFF		Output OFF	Output OFF			Output OFF
78		Output OFF	Output OFF	Output OFF			Output OFF
79	Output OFF	Output OFF	Output OFF	Output OFF			Output OFF
80					Output OFF		Output OFF
81	Output OFF				Output OFF		Output OFF
82		Output OFF			Output OFF		Output OFF
83	Output OFF	Output OFF			Output OFF		Output OFF
84			Output OFF		Output OFF		Output OFF
85	Output OFF		Output OFF		Output OFF		Output OFF
86		Output OFF	Output OFF		Output OFF		Output OFF
87	Output OFF	Output OFF	Output OFF		Output OFF		Output OFF
88				Output OFF	Output OFF		Output OFF
89	Output OFF			Output OFF	Output OFF		Output OFF
90		Output OFF		Output OFF	Output OFF		Output OFF
91	Output OFF	Output OFF		Output OFF	Output OFF		Output OFF
92			Output OFF	Output OFF	Output OFF		Output OFF
93	Output OFF		Output OFF	Output OFF	Output OFF		Output OFF
94		Output OFF	Output OFF	Output OFF	Output OFF		Output OFF
95	Output OFF	Output OFF	Output OFF	Output OFF	Output OFF		Output OFF
96						Output OFF	Output OFF
97	Output OFF					Output OFF	Output OFF
98		Output OFF				Output OFF	Output OFF





SoU	OUT1	OUT2	OUT3	OUT4	OUT5	OUT6	Open Collector
99	Output OFF	Output OFF				Output OFF	Output OFF
100			Output OFF			Output OFF	Output OFF
101	Output OFF		Output OFF			Output OFF	Output OFF
102		Output OFF	Output OFF			Output OFF	Output OFF
103	Output OFF	Output OFF	Output OFF			Output OFF	Output OFF
104				Output OFF		Output OFF	Output OFF
105	Output OFF			Output OFF		Output OFF	Output OFF
106		Output OFF		Output OFF		Output OFF	Output OFF
107	Output OFF	Output OFF		Output OFF		Output OFF	Output OFF
108			Output OFF	Output OFF		Output OFF	Output OFF
109	Output OFF		Output OFF	Output OFF		Output OFF	Output OFF
110		Output OFF	Output OFF	Output OFF		Output OFF	Output OFF
111	Output OFF	Output OFF	Output OFF	Output OFF		Output OFF	Output OFF
112					Output OFF	Output OFF	Output OFF
113	Output OFF				Output OFF	Output OFF	Output OFF
114		Output OFF			Output OFF	Output OFF	Output OFF
115	Output OFF	Output OFF			Output OFF	Output OFF	Output OFF
116			Output OFF		Output OFF	Output OFF	Output OFF
117	Output OFF		Output OFF		Output OFF	Output OFF	Output OFF
118		Output OFF	Output OFF		Output OFF	Output OFF	Output OFF
119	Output OFF	Output OFF	Output OFF		Output OFF	Output OFF	Output OFF
120				Output OFF	Output OFF	Output OFF	Output OFF
121	Output OFF			Output OFF	Output OFF	Output OFF	Output OFF
122		Output OFF		Output OFF	Output OFF	Output OFF	Output OFF
123	Output OFF	Output OFF		Output OFF	Output OFF	Output OFF	Output OFF
124			Output OFF	Output OFF	Output OFF	Output OFF	Output OFF
125	Output OFF		Output OFF	Output OFF	Output OFF	Output OFF	Output OFF
126		Output OFF	Output OFF	Output OFF	Output OFF	Output OFF	Output OFF
127	Output OFF	Output OFF	Output OFF	Output OFF	Output OFF	Output OFF	Output OFF

**Eliwell Controls s.r.l.**

Via dell'Industria, 15 • Z.I. Paludi  
32010 Pieve d'Alpago (BL) ITALY  
Telephone: +39 0437 986 111  
Facsimile: +39 0437 989 066

**[www.eliwell.it](http://www.eliwell.it)**

**Technical Customer Support:**

Technical helpline: +39 0437 986 300  
E-mail: [techsuppeliwell@invensys.com](mailto:techsuppeliwell@invensys.com)

**Sales**

Telephone: +39 0437 986 100 (Italy)  
+39 0437 986 200 (other countries)  
E-mail: [saleseliwell@invensys.com](mailto:saleseliwell@invensys.com)



ISO 9001